

M-14246

1

LIST OF PARTS

DESCRIPTION	MATERIAL	FINISH
FLANGE	ALUMINUM	PER CAT#
COVER	ALUMINUM	PER CAT#
FACE PLATE	STAINLESS STEEL	
RECEPTACLE W/USB CHARGE	T.PLASTIC	SEE TABLE
SCREWS	STEEL	ZINC PLATE
SCREWS	S. STEEL	
THREAD PLUG	ALUMINUM	PER CAT#
POWER CORD	PVC	BLACK
PINS	S. STEEL	
GAS SPRING	STEEL	
RETAINING RING	S. STEEL	
PAWL	T.PLASTIC	
PROTECT. CAP	ELASTOMER	
LATCH	S. STEEL	

DIMENSION SHEET FOR CAT. NO. SEE TABLE

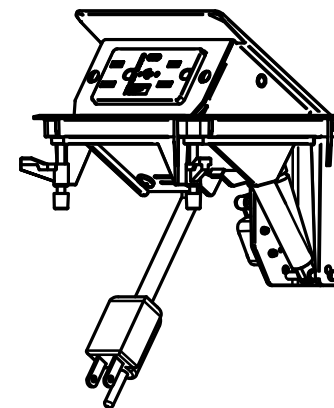
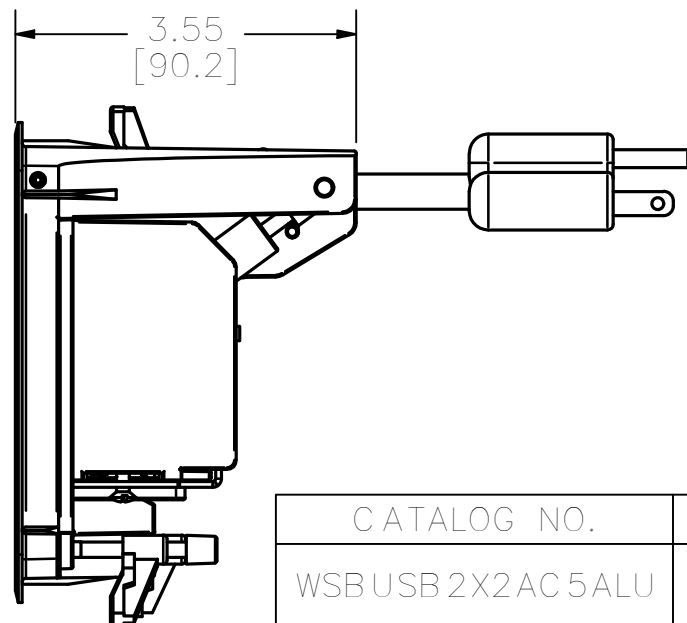
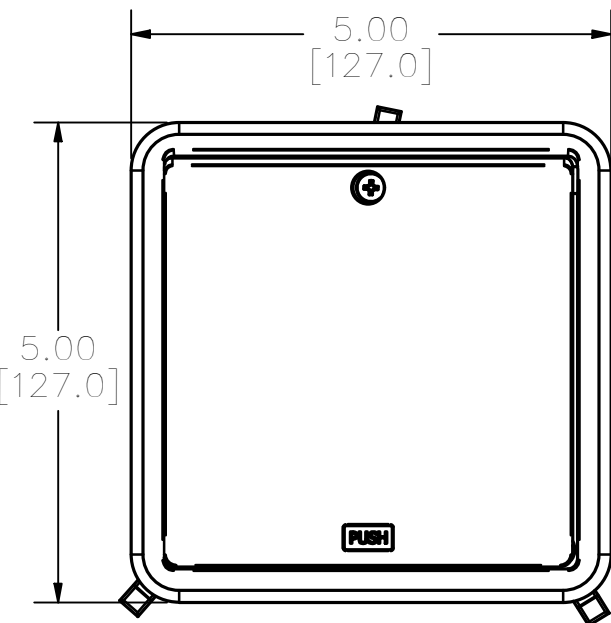

CATALOG NO.	DESCRIPTION	FINISH	USB COLOR
WSBUSB2X2AC5ALU	WRK SURFC BOX FLIP UP, USB2X2AC5, ALU	BRUSHED ALUMINUM	GRAY
WSBUSB2X2AC5BLK	WRK SURFC BOX FLIP UP, USB2X2AC5, BLACK	BLACK POWDER COAT	BLACK
WSBUSB2X2AC5WHT	WRK SURFC BOX FLIP UP, USB2X2AC5, WHITE	WHITE POWDER COAT	WHITE

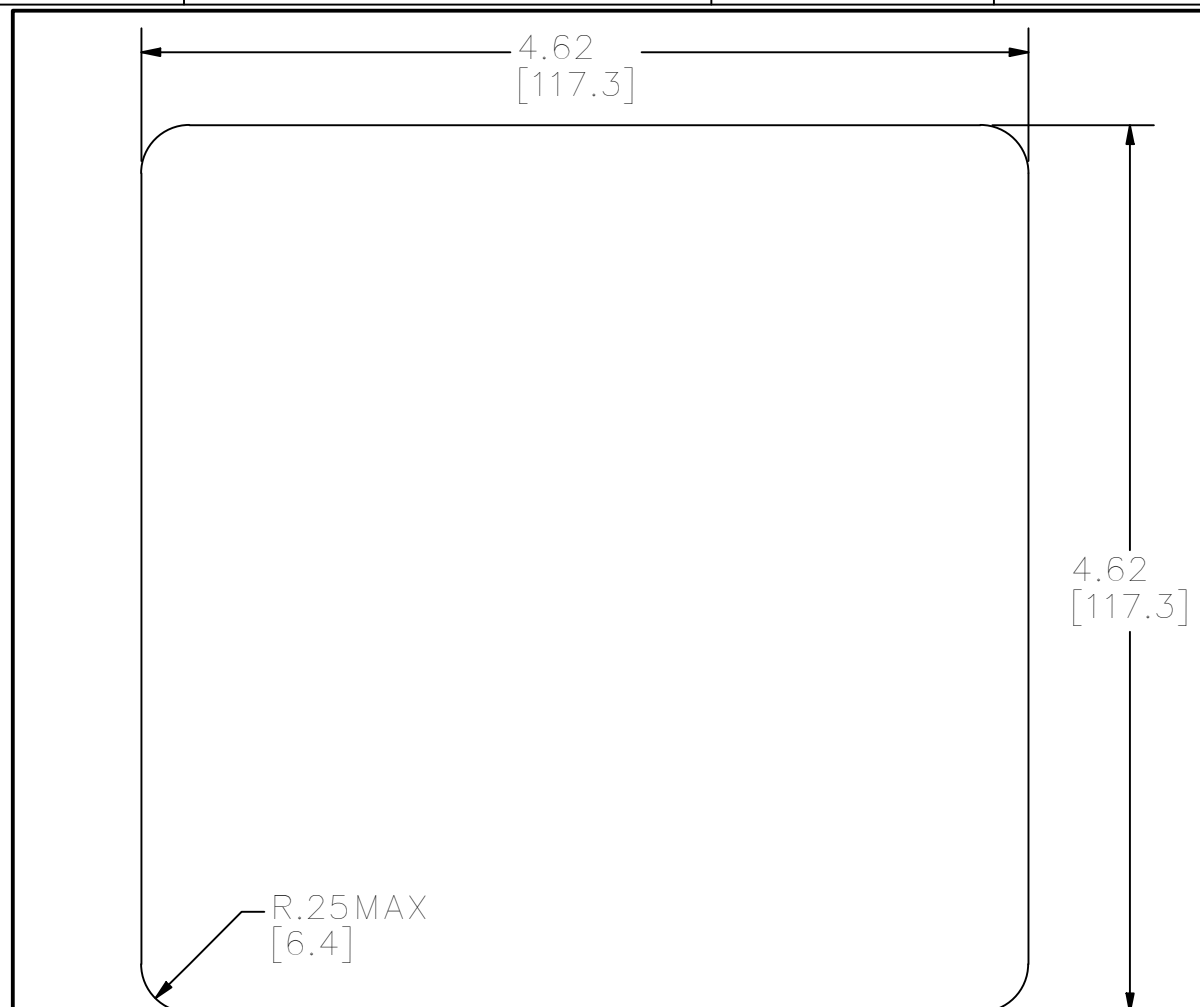
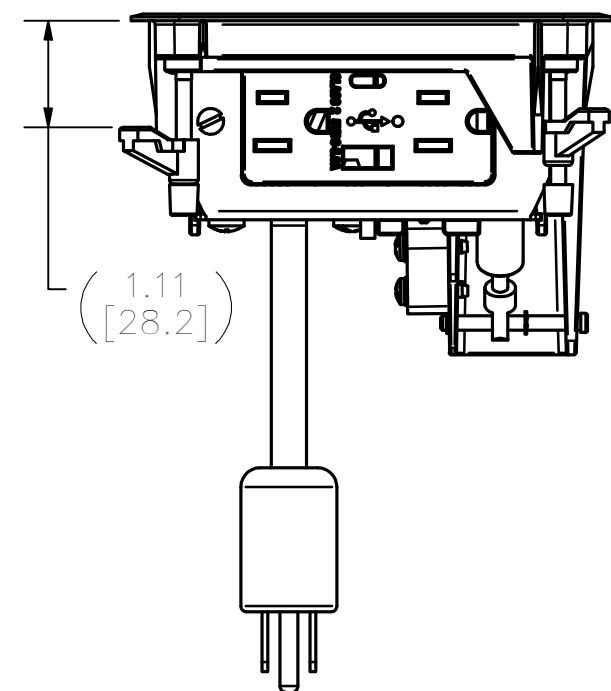

CUTOUT OPENING (FULL SCALE)

NOTES:

- RATING / TYPE:
RECEPTACLE: 15A 125V.
(1) TYPE A & (1) TYPE-C USB PORTS; 5 AMP, 5 VOLT OUTPUT.
POWER CORD: NEMA 5-15P.
- ALL DIMENSIONS ARE IN INCHES [mm] EXCEPT POWER CORD LENGTH IN FOOT.
- c-UL-us LISTED.

CAGE CODE 74545

1	INITIAL RELEASE DCN 200519154947	RM	WOV	05/29/20
REV	DESCRIPTION	APP	DATE	

THE DESIGN AND DIMENSIONS OF THE PRODUCT SHOWN ON THIS DRAWING ARE SUBJECT TO CHANGE WITHOUT NOTICE. DIMENSIONS ARE IN INCHES [mm].

TITLE
HOSPITALITY BOX



WIRING DEVICE-KELLEMS
HUBBELL INCORPORATED
SHELTON, CT

TOLERANCES UNLESS OTHERWISE SPECIFIED .XX = ± .01 .XXX = ± .005 ANGLE TOL. ±2'	DR. BY RM	SCALE 1/2
	CHK. BY	DATE 5/29/20

B

M-14246

1