

M-14337

2

CAT. NO. & RATING PRINTED ON BLADE HOLDER, COLOR CODE BY VOLTAGE

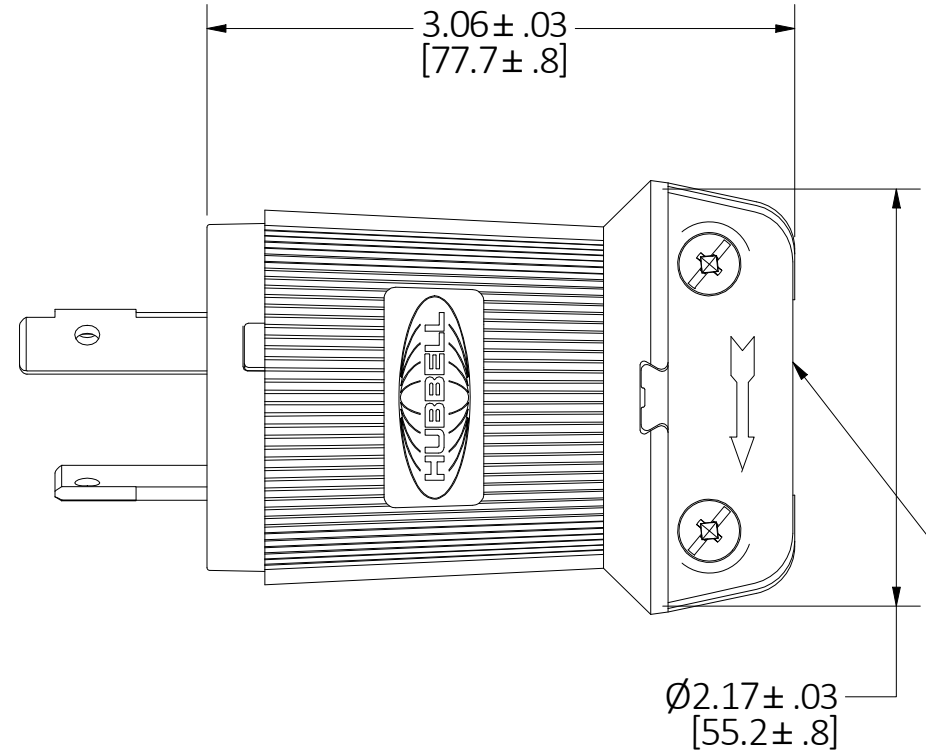
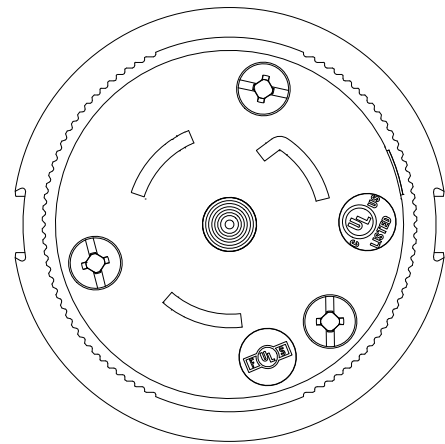
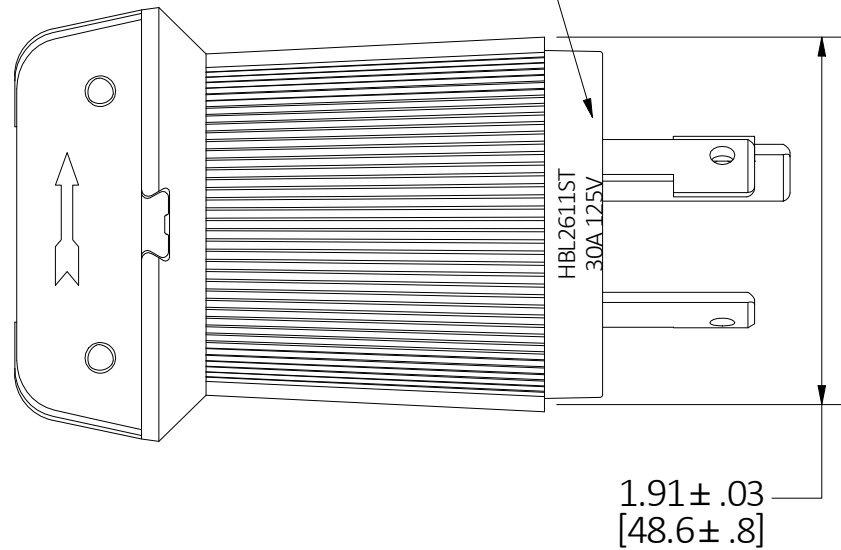

CORD CLAMP RANGE:
CORD: 14/3 - 8/3 TYPE S
14/3 - 12/3 TYPE SJ

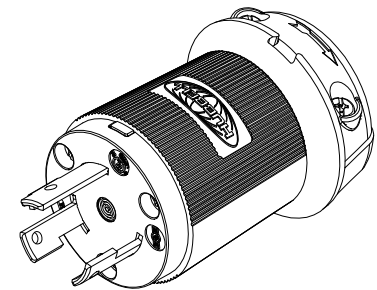

CAT. NO. HBL2611ST
(NOT SHOWN TO SCALE)

| 2 | ADDED CAT# HBL2611STBK & HBL2621STBK, REPLACED NATURAL WITH NATURAL, BLACK FOR CORD CLAMP & BLADE HOLDER PER DCN 221011024714 AM | MAM | 12/09/22 |
|-----|----------------------------------------------------------------------------------------------------------------------------------------------------|-----|----------|
| REV | DESCRIPTION | APP | DATE |

THE DESIGN AND DIMENSIONS OF THE PRODUCT SHOWN ON THIS DRAWING ARE SUBJECT TO CHANGE WITHOUT NOTICE. DIMENSIONS ARE IN INCHES [mm].

TITLE
30A 3-WIRE TWIST-LOCK® EDGE SCREWLESS TERMINATION PLUG

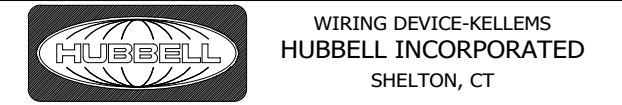

| | | |
|-----------------------------------------------------------------------------------------|-------------|---------------|
| TOLERANCES UNLESS OTHERWISE SPECIFIED .XX = ± .01 .XXX = ± .005 ANGLE TOL. ±2' | DR. BY AM | SCALE 1 : 1 |
| | CHK. BY MAM | DATE 04/29/22 |

| NEMA NO. | RATING | POLE/WIRE | CAT. NO. | BLADE CONFIGURATION | VOLTAGE COLOR CODE |
|----------|--------|-----------------|--------------------------|---------------------|--------------------|
| L5-30P | 125V | 2P/3W GROUNDING | HBL2611ST HBL2611STBK | | YELLOW |
| L6-30P | 250V | 2P/3W GROUNDING | HBL2621ST HBL2621STBK | | BLUE |

NOTES (UNLESS OTHERWISE SPECIFIED):

- DIMENSIONS ARE IN INCHES [mm].
- ALL DEVICES ARE cULus LISTED & FED SPEC.
- CORD TYPES: S & SJ
- CORD CLAMP RANGE: 0.36 [9 mm] - 0.93 [24 mm].
- WIRING TERMINAL ACCOMMODATION: 14 AWG - 8 AWG STRANDED COPPER WIRE ONLY.
- ASSEMBLY SCREWS ARE PHILLIPS/SLOTTED/ROBERTSON HEAD.
- CATALOG NUMBERS & RATING ARE PAD PRINTED ON THE SIDE OF THE DEVICE, COLOR CODED BY VOLTAGE.