

M-14338

1

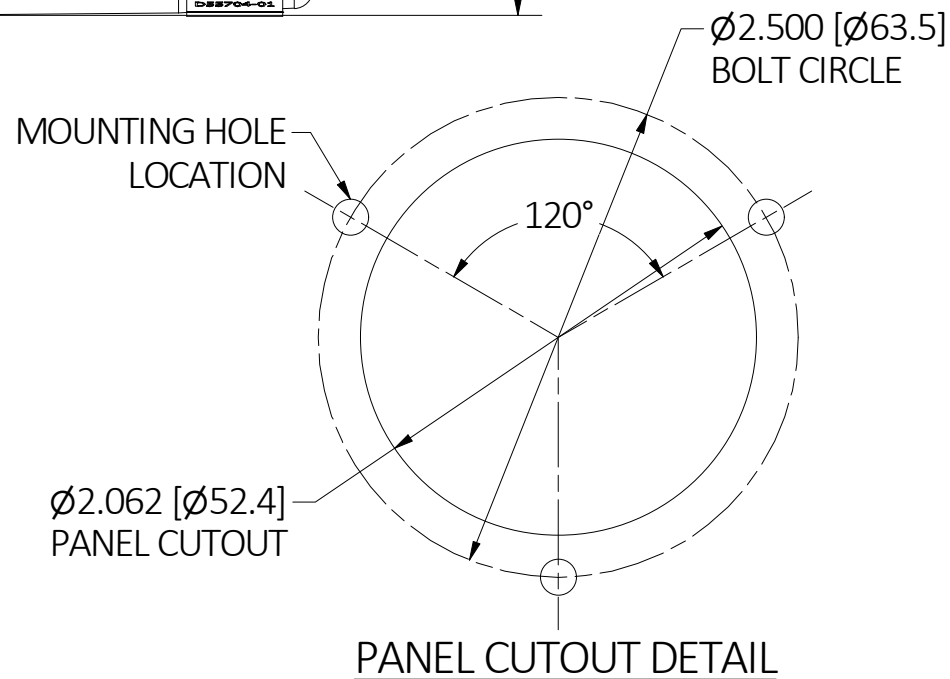

LIST OF PARTS		
DESCRIPTION	MATERIAL	FINISH
CASING	NYLON	NATURAL
BLADE HOLDER	NYLON	NATURAL
RETAINER	NYLON	BLACK
BLADE	COPPER ALLOY	
SPRING	STAINLESS STEEL	
PLUNGER	NYLON	
ASSEMBLY FASTENERS	STEEL	ZINC PLATE

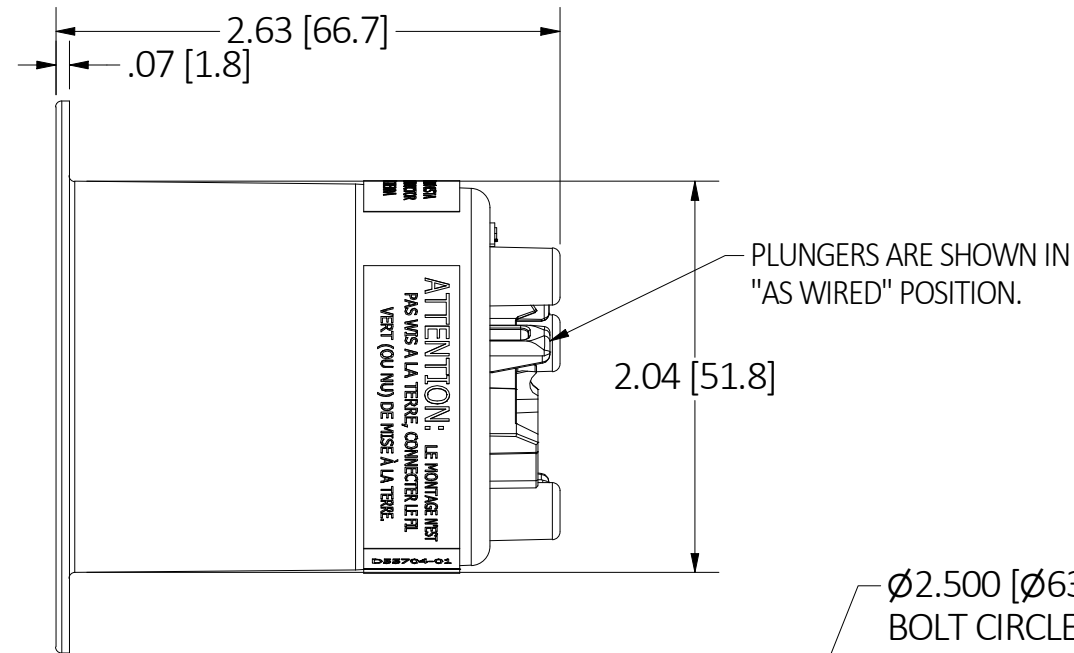
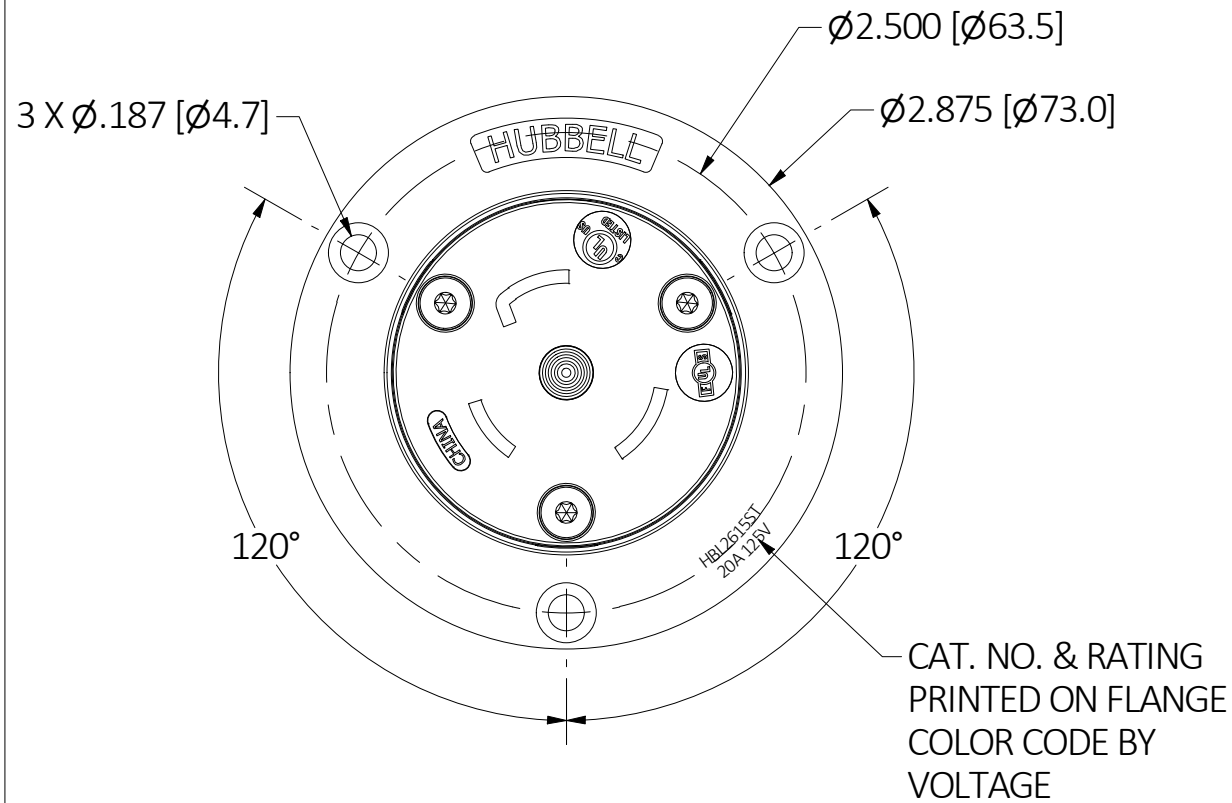
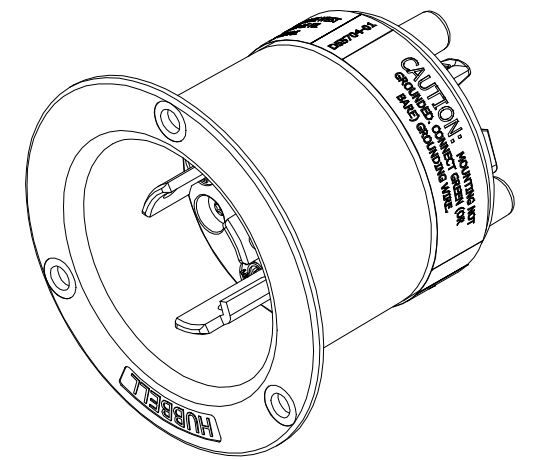

CATALOG NO. HBL2615
NOT SHOWN TO SCALE

NEMA NO.	RATING	POLE/WIRE	CAT. NO.	CONFIGURATION	VOLTAGE COLOR CODE
L5-30P	125V	2P/3W GROUNDING	HBL2615ST		YELLOW
L6-30P	250V	2P/3W GROUNDING	HBL2625ST		BLUE

NOTES (UNLESS OTHERWISE SPECIFIED):

- DIMENSIONS ARE IN INCHES [mm].
- ALL DEVICES ARE cULus LISTED & FED SPEC.
- WIRING TERMINAL ACCOMMODATION:
 - SOLID WIRE: 14 AWG - 10 AWG COPPER WIRE ONLY
 - STRANDED WIRE (INCLUDING COMPACT STRANDED): 14 AWG - 8 AWG COPPER WIRE ONLY
- CONDUCTOR STRIP LENGTH: 3/4" (19 mm).
- MOUNTING HOLES IN FLANGE ARE SIZED FOR #8 SCREWS. MOUNTING SCREWS NOT SUPPLIED.
- CATALOG NUMBERS & RATING ARE PAD PRINTED ON THE FLANGE OF THE DEVICE, COLOR CODED BY VOLTAGE.

REV	DESCRIPTION	APP	DATE
1	INITIAL RELEASE PER DCN 220401018715 AM	AM	05/18/22

THE DESIGN AND DIMENSIONS OF THE PRODUCT SHOWN ON THIS DRAWING ARE SUBJECT TO CHANGE WITHOUT NOTICE. DIMENSIONS ARE IN INCHES [mm].

TITLE
30A 3-WIRE TWIST-LOCK® EDGE SCREWLESS TERMINATION INLET



WIRING DEVICE-KELLEMS
HUBBELL INCORPORATED
SHELTON, CT

TOLERANCES UNLESS OTHERWISE SPECIFIED
.XX = ± .01
.XXX = ± .005
ANGLE TOL. ±2°

DR. BY	AM	SCALE	1 : 1
CHK. BY	MAM	DATE	04/29/22