

M-14431

2

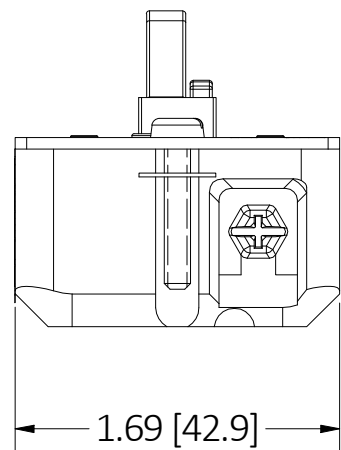
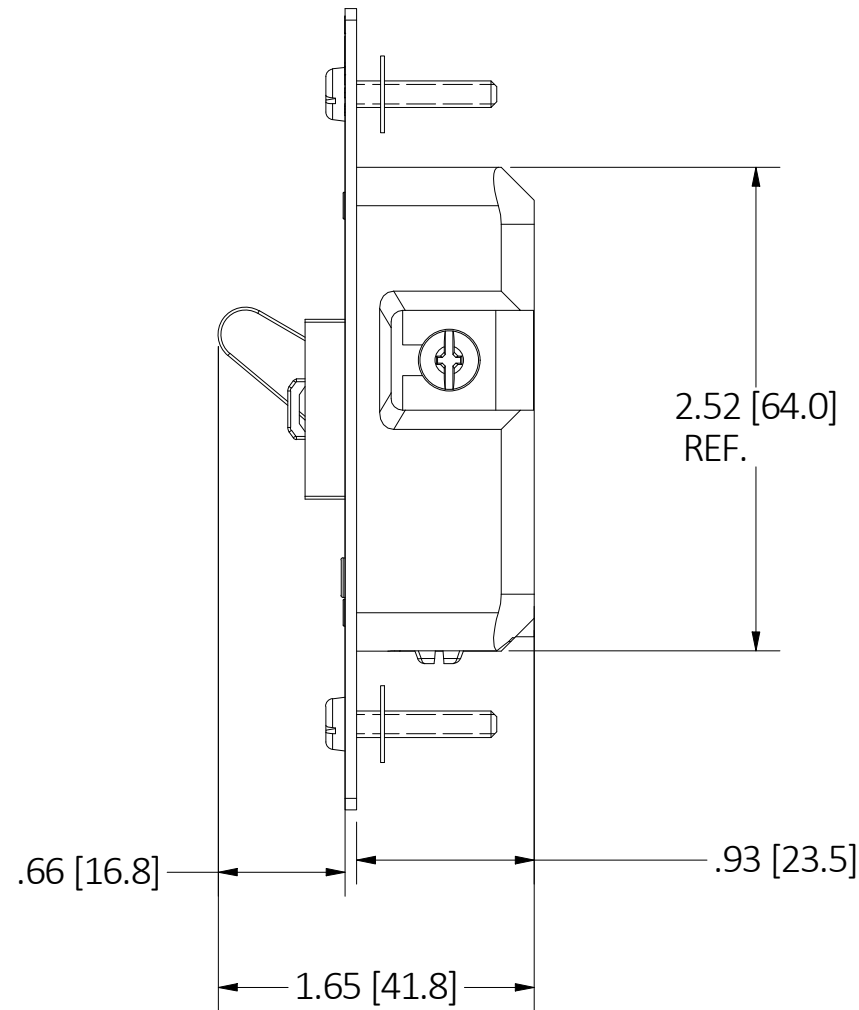
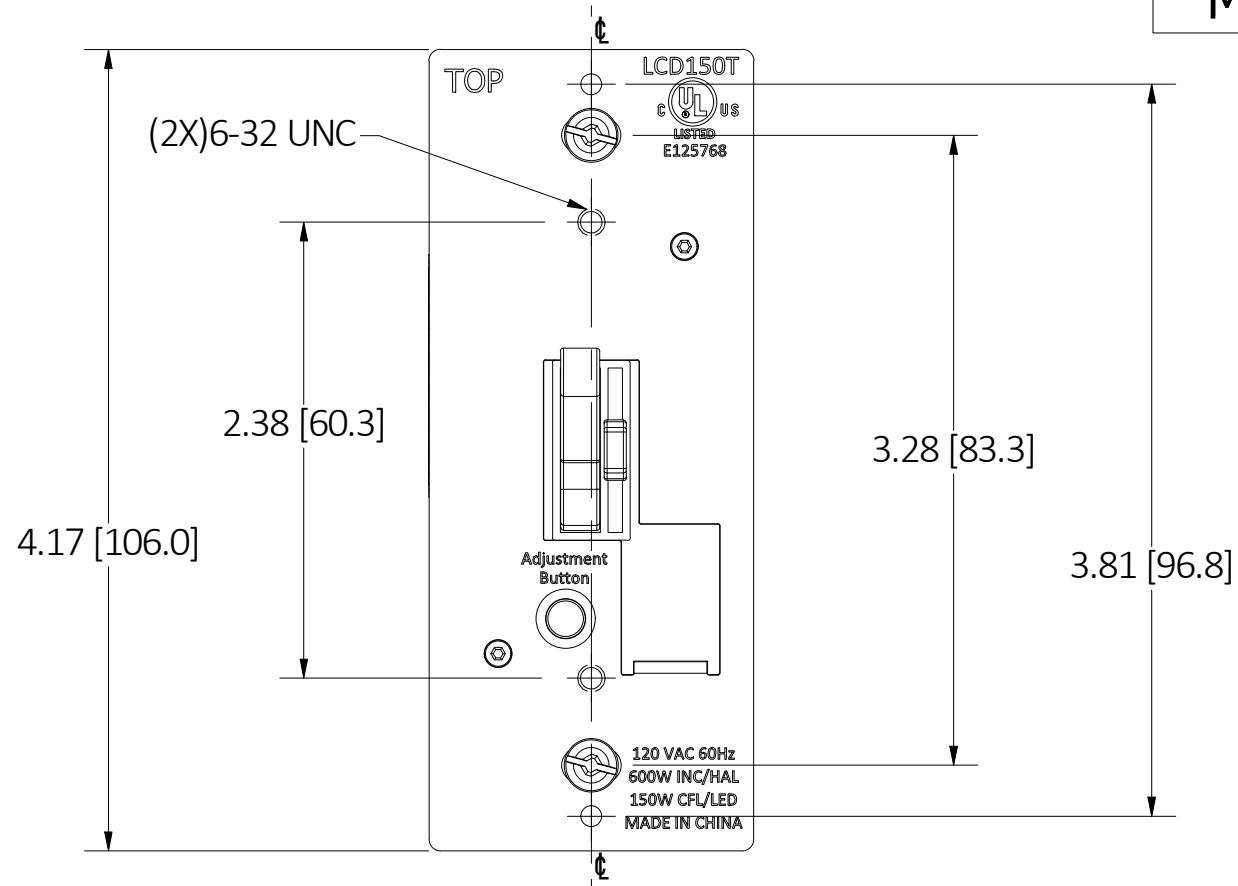

NOTES:

1. INPUT RATING: 120VAC, 60Hz.
2. SWITCH TYPE: SINGLE POLE & 3-WAY.
3. REMOVED.
4. STORAGE TEMPERATURE: -40°F TO 185°F [-40°C TO 85°C].
5. RATING WATTAGE: LED/CFL 150W (1.5A), INCANDESCENT 600W.
6. TERMINAL CAPACITY: #18 - #12 AWG; WIRING TYPE: SCREW TERMINAL (BACK & SIDE)
7. ALL DIMENSIONS ARE IN INCHES [mm].

CAGE CODE 74545

LIST OF PARTS

DESCRIPTION	MATERIAL	FINISH
TOGGLE	THERMOPLASTIC	SEE TABLE PER CAT.#
TOGGLE FRAME	THERMOPLASTIC	SEE TABLE PER CAT.#
SLIDE BAR	THERMOPLASTIC	SEE TABLE PER CAT.#
YOKE	ALUMINUM	
BASE	THERMOPLASTIC	BLACK
GR. SCREW	STEEL	Zn PLATE+GREEN DYE
BLACK SCREW	STEEL	Zn PLATE + BLACK DYE
RED SCREWS	STEEL	Zn PLATE + RED DYE
MOUNTING SCREW	STEEL	Zn PLATE

2	REMOVED NOTE#3 PER DCN#211101013930	D.LI	10/13/21
1	NEW RELEASE PER DCN#210924012757	D.LI	9/27/21
REV	DESCRIPTION	APP	DATE

THE DESIGN AND DIMENSIONS OF THE PRODUCT SHOWN ON THIS DRAWING ARE SUBJECT TO CHANGE WITHOUT NOTICE. DIMENSIONS ARE IN INCHES [mm].

CAT.#	DESCRIPTION	COLOR
LCD150TW	DIM TOGGLE SP&3W 150W LED CFL WH	WHITE
LCD150TI	DIM TOGGLE SP&3W 150W LED CFL IV	IVORY
LCD150TLA	DIM TOGGLE SP&3W 150W LED CFL LA	LIGHT ALMOND

TITLE

TOGGLE DIMMER



WIRING DEVICE-KELLEMS
HUBBELL INCORPORATED
SHELTON, CT

TOLERANCES UNLESS OTHERWISE SPECIFIED .XX = ± .01 .XXX = ± .005 ANGLE TOL. ±2'	DR. BY D.LI	SCALE 1 : 1
	CHK. BY	DATE 8/10/2021

DIMENSION SHEET FOR CAT. NO. **B** M-14431 **2**