

M-14505

2

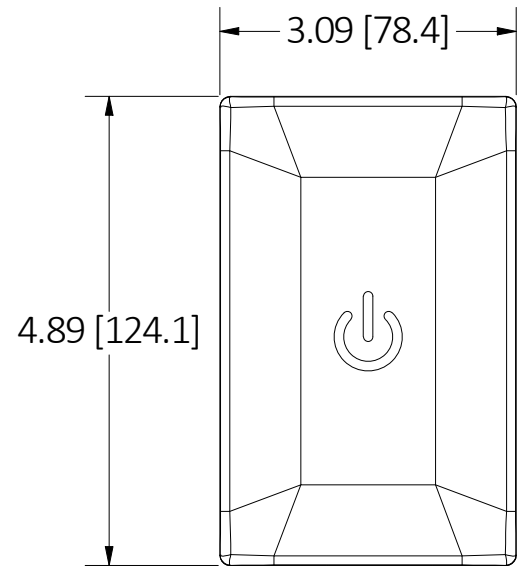

WSS1277P

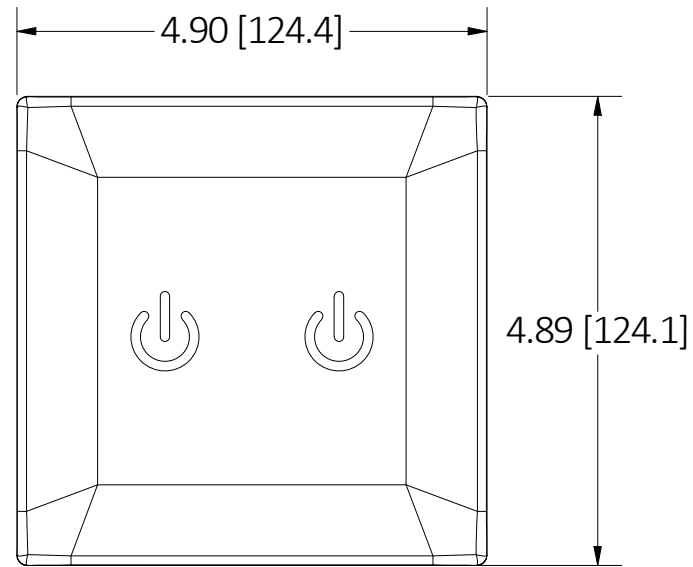

WSS2277P

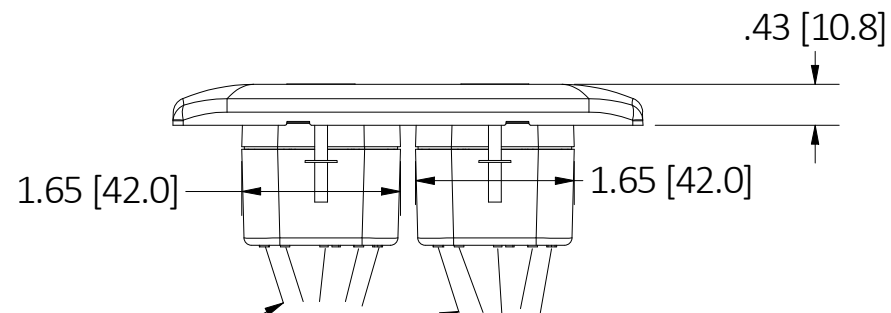
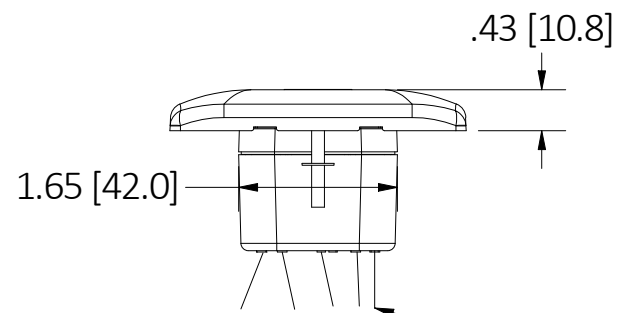
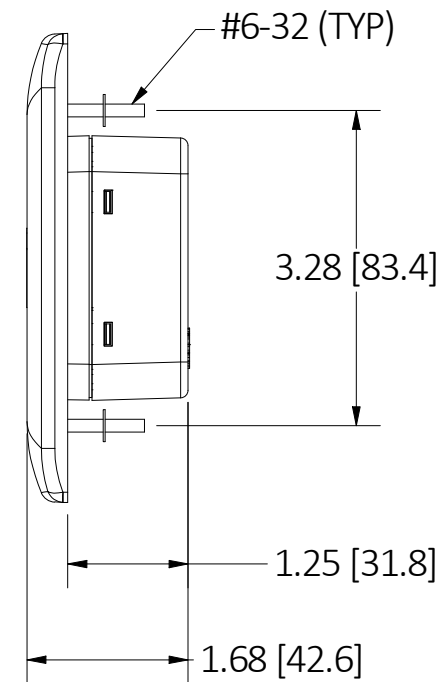

6" LONG LEAD WIRES:
 #16 AWG, BLACK
 #16 AWG, RED
 #14 AWG, GREEN
 #16 AWG, WHITE
 #16 AWG, YELLOW

NOTES:

- ALL DIMENSIONS ARE IN INCHES [mm].
- INPUT: 120-277Vac 60Hz
 LOAD: 120Vac, 5A ELECTRONIC BALLAST CFL/LED.
 120Vac, 10A STANDARD BALLAST.
 120Vac, 10A 1,200W TUNGSTEN, 1/2 HP Motor.
 277Vac, 8A STANDARD BALLAST.
- COMPATIBLE WITH COMMON LIGHTING LOADS SUCH AS LED, INCANDESCENT, ELECTRICAL/MAGNETIC FLUORESCENT.

CAGE CODE 74545

CAT.#	DESCRIPTION	COLOR
WSS1277PW	1-G SCRUB SWITCH, PLASTIC COVER	WHITE
WSS2277PW	2 G SCRUB SWITCH, PLASTIC COVER	WHITE

LIST OF PARTS		
DESCRIPTION	MATERIAL	FINISH
WALL PLATE	THERMOPLASTIC	SEE TABLE PER CAT.#
YOKE	STEEL	Zn PLATE
BASE	THERMOPLASTIC	WHITE
COVER	THERMOPLASTIC	WHITE
MOUNTING SCREW	STEEL	Zn PLATE

REV	DESCRIPTION	APP	DATE
2	"60Hz" WAS "50/60Hz" PER DCN#221201026052	D.LI	12/1/22
1	NEW RELEASE PER DCN #220920024204	D.LI	7/29/22

THE DESIGN AND DIMENSIONS OF THE PRODUCT SHOWN ON THIS DRAWING ARE SUBJECT TO CHANGE WITHOUT NOTICE. DIMENSIONS ARE IN INCHES [mm].

TITLE
 SP/3- OR 4-WAY SCRUB TAP/TOUCH SWITCH, PLASTIC COVER



WIRING DEVICE-KELLEMS
 HUBBELL INCORPORATED
 SHELTON, CT

TOLERANCES UNLESS OTHERWISE SPECIFIED .XX = ± .01 .XXX = ± .005 ANGLE TOL. ±2'	DR. BY D.LI	SCALE 1/2
	CHK. BY	DATE 7/29/22

DIMENSION SHEET FOR CAT. NO. SEE TABLE

B

M-14505

2