

M-14512 1

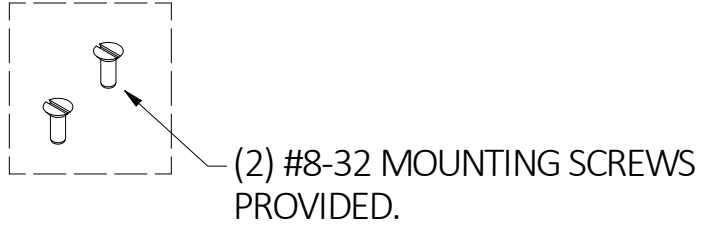
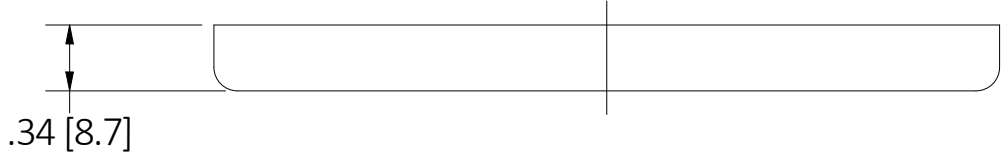
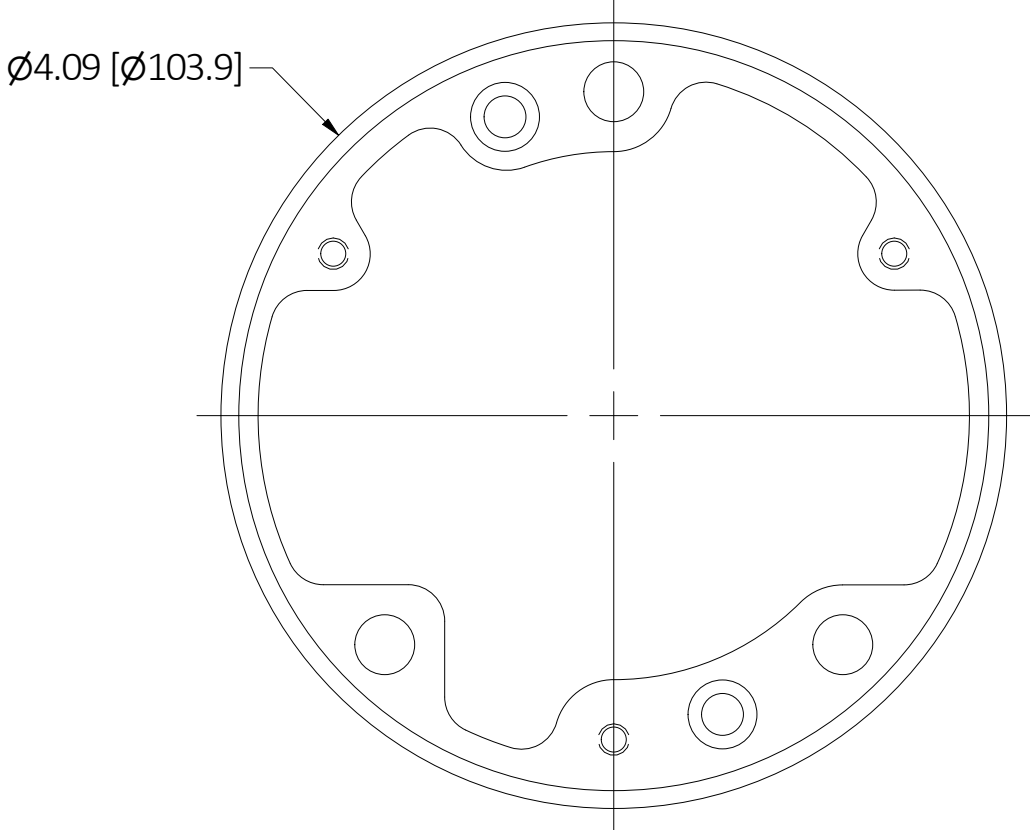

NOTES:
1. ALL DIMENSIONS ARE IN INCHES [MM].

| TABLE 1 | | |
|----------|-------------------------------------|-----------------------|
| CAT. NO. | DESCRIPTION | FLANGED RING MATERIAL |
| S5016PG | COVER FLANGE, ROUND, PRE-GALV STEEL | GALV. STEEL |
| S5016 | COVER FLANGE, ROUND, BRASS | BRASS |
| SA5016 | COVER FLANGE, ROUND, ALUM. | ALUMINUM |

| LIST OF PARTS | | |
|---------------|-------------|------------|
| DESCRIPTION | MATERIAL | FINISH |
| FLANGED RING | SEE TABLE 1 | - |
| SCREWS | STEEL | ZINC PLATE |
| | | |
| | | |
| | | |
| | | |
| | | |
| | | |
| | | |
| | | |
| | | |

| REV | DESCRIPTION | APP | DATE |
|-----|--|-----|---------|
| 1 | INITIAL RELEASE WITH DCN #211214015266 | SW | 4/13/22 |

THE DESIGN AND DIMENSIONS OF THE PRODUCT SHOWN ON THIS DRAWING ARE SUBJECT TO CHANGE WITHOUT NOTICE. DIMENSIONS ARE IN INCHES [mm].

TITLE
COVER FLANGE, ROUND



WIRING DEVICE-KELLEMS
HUBBELL INCORPORATED
SHELTON, CT

| | | |
|---|------------|--------------|
| TOLERANCES UNLESS OTHERWISE SPECIFIED .XX = ± .01 .XXX = ± .005 ANGLE TOL. ±2' | DR. BY PSV | SCALE 1:2 |
| | CHK. BY SW | DATE 4/13/22 |

DIMENSION SHEET FOR CAT. NO. **B** **M-14512** **1**
SEE TABLE 1