

M-14524

1

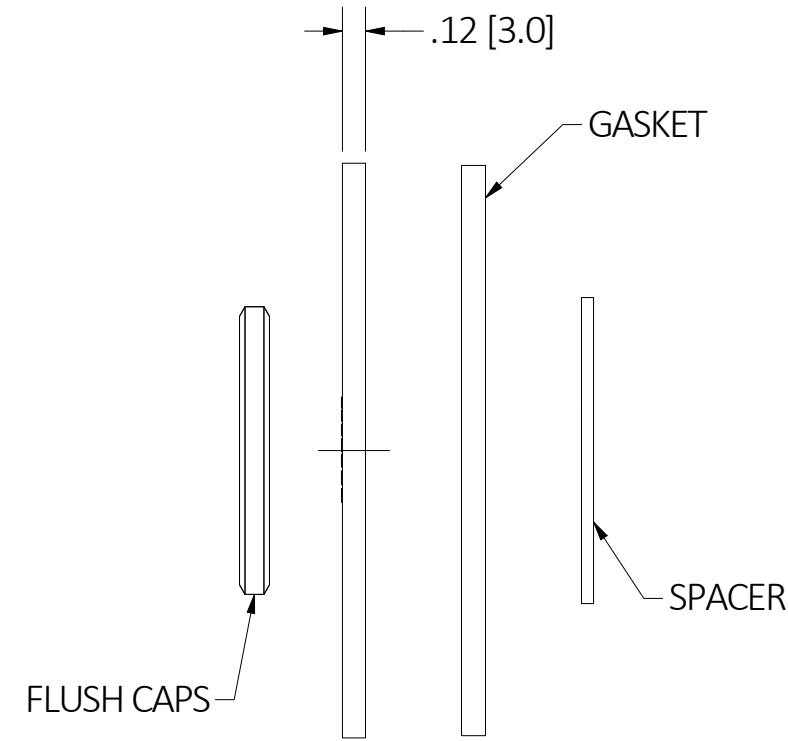
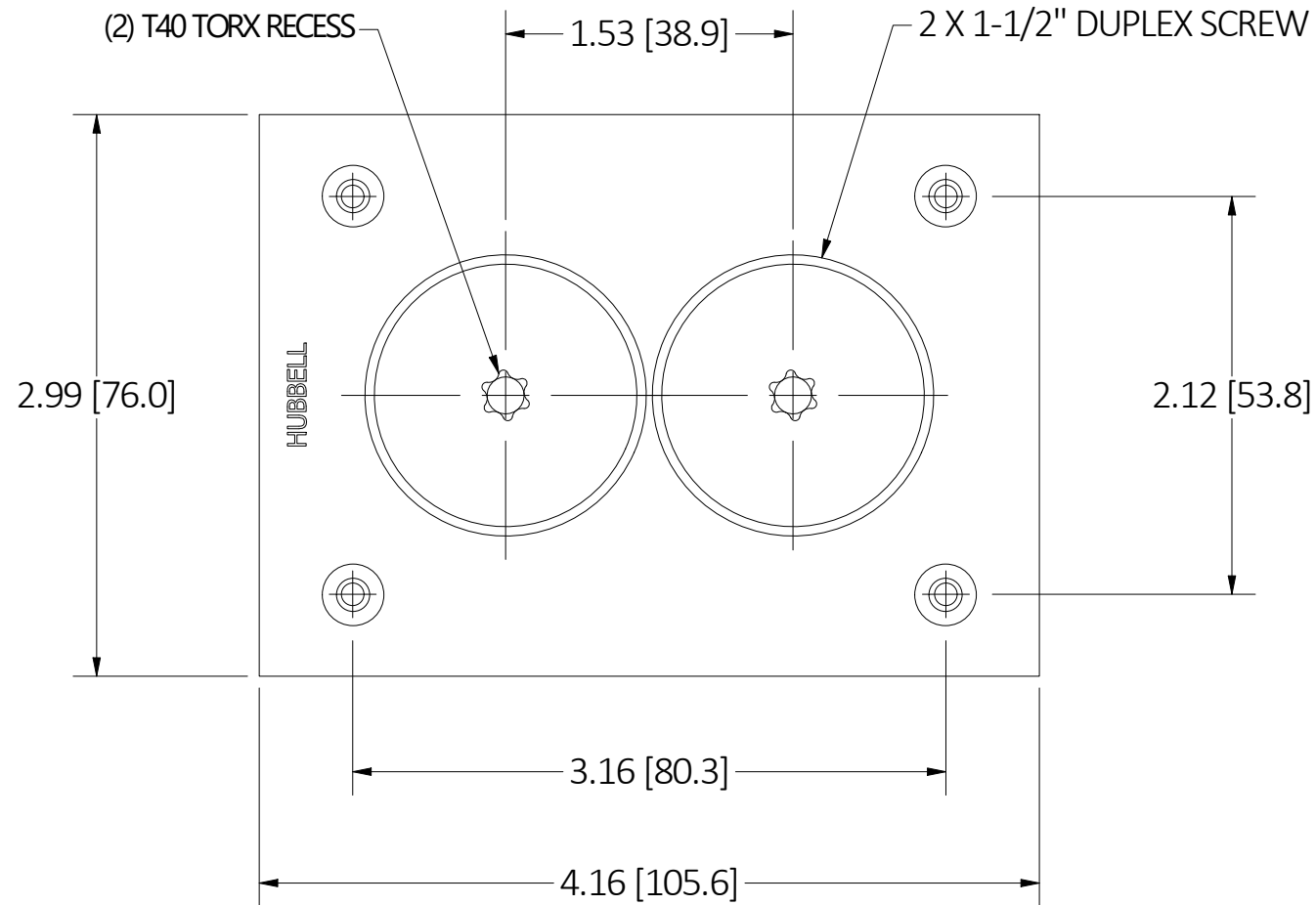

NOTE:
1. DIMENSIONS ARE IN INCHES [MM].

LIST OF PARTS

| DESCRIPTION | MATERIAL | FINISH |
|------------------|------------------|---------|
| COVER PLATE | SEE TABLE | BRUSHED |
| FLUSH CAPS | SEE TABLE | BRUSHED |
| COVER GASKET | ELASTOMER | |
| FLAT HEAD SCREWS | SEE TABLE | |
| SPACER | GALVANIZED STEEL | |
| | | |
| | | |
| | | |
| | | |
| | | |
| | | |
| | | |
| | | |
| | | |

DIMENSION SHEET FOR CAT. NO. SEE TABLE

B

M-14524

1

| 1 | INITIAL RELEASE PER DCN #220422019408 | SW | 4/25/22 |
|-----|---------------------------------------|-----|---------|
| REV | DESCRIPTION | APP | DATE |

THE DESIGN AND DIMENSIONS OF THE PRODUCT SHOWN ON THIS DRAWING ARE SUBJECT TO CHANGE WITHOUT NOTICE. DIMENSIONS ARE IN INCHES [mm].

TITLE
RECT. FLOORBOX COVER WITH T40 TORX TAMPER RESISTANT CAP FOR DUPLEX RECEPTACLE

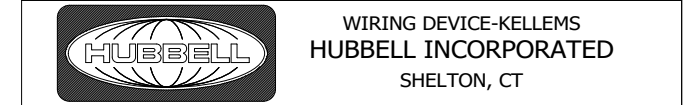

| | | |
|---|------------|--------------|
| TOLERANCES UNLESS OTHERWISE SPECIFIED .XX = ± .01 .XXX = ± .005 ANGLE TOL. ±2' | DR. BY PSV | SCALE 1:1 |
| | CHK. BY SW | DATE 4/25/22 |

| TABLE | | | |
|-------------|----------|-----------|-----------------|
| CATALOG No. | COVER | FLUSH CAP | FLAT HEAD SCREW |
| S3625TR | BRASS | BRASS | BRASS |
| SA3625TR | ALUMINUM | ALUMINUM | STAINLESS STEEL |