

M-14573

1

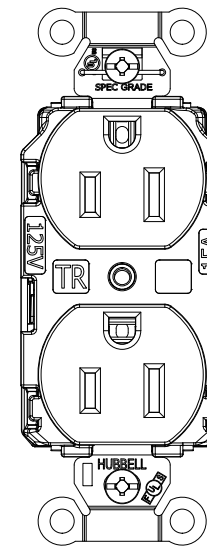
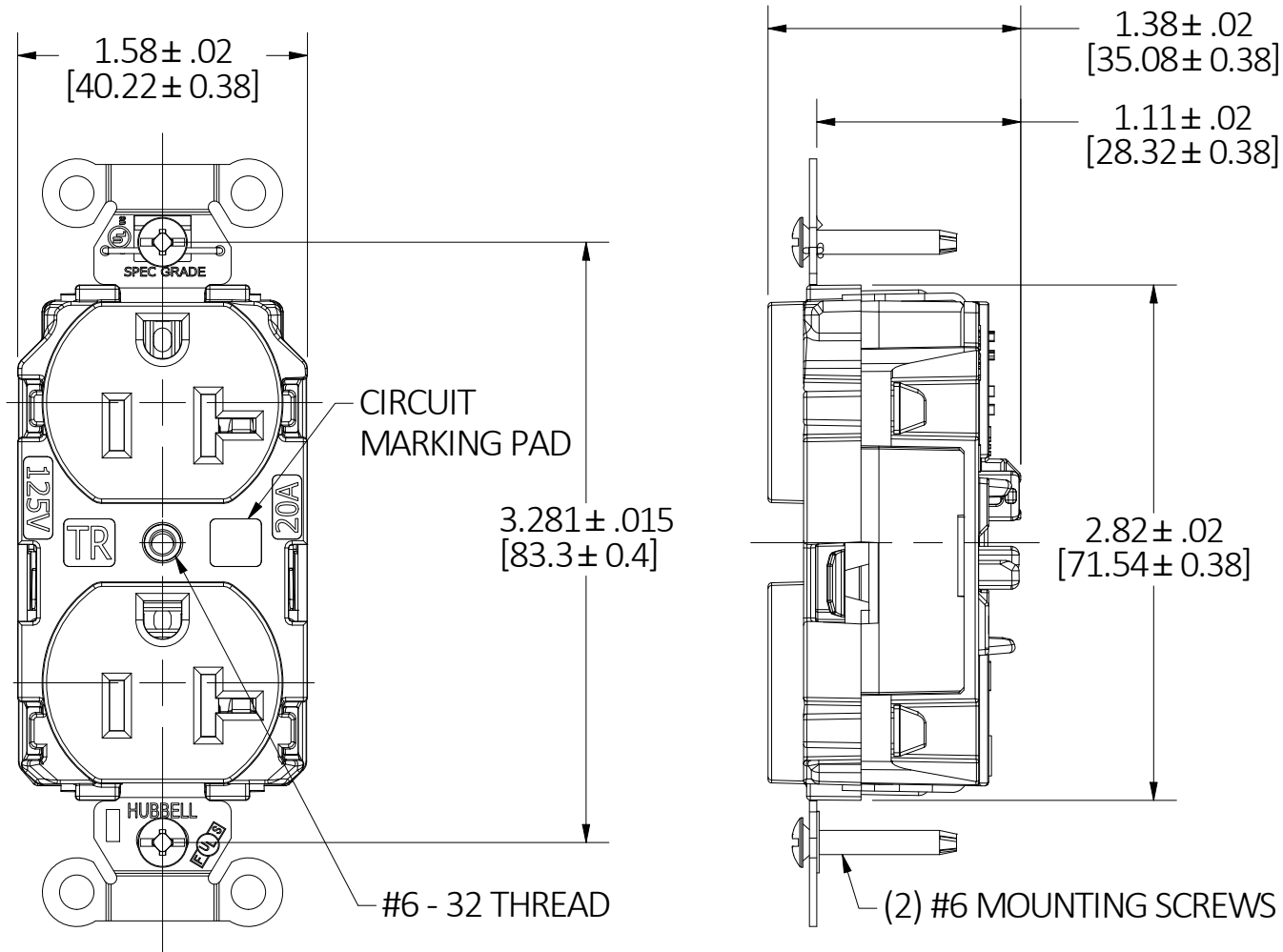

15A/125V

LIST OF PARTS		
DESCRIPTION	MATERIAL	FINISH
TOP COVER	PC	-
TR ASSEMBLY	ACETAL/SS	-
BASE	PC	-
BRIDGE	.04 GALV. STL.	-
GROUND CONTACTS	COPPER ALLOY	-
LINE CONTACTS	COPPER ALLOY	-
REAR COVER	PC	-
PLUNGER	NYLON	-
SPRING	STAINLESS STEEL	-
STAPLE	STAINLESS STEEL	-
WASHER	PVC FILM	BLACK
GROUND STRAP	COPPER ALLOY	-
MOUNTING SCREW	STEEL	ZINC PLATE

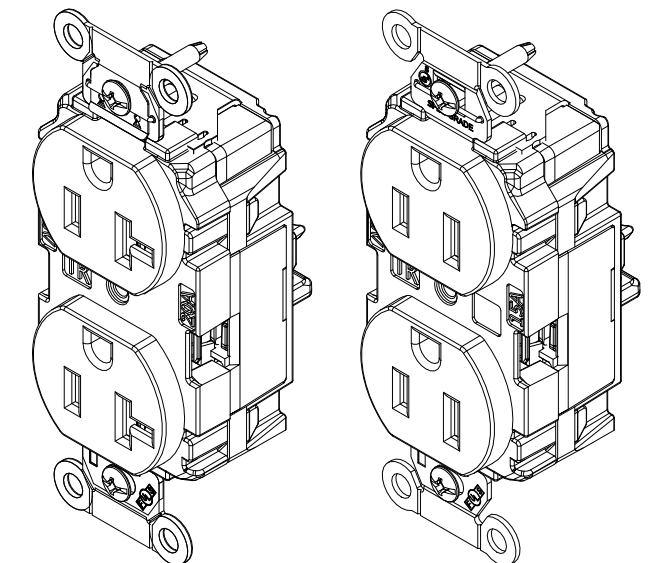

CATALOG NO: 5362STTR CATALOG NO: 5262STTR
(NOT SHOWN TO SCALE) (NOT SHOWN TO SCALE)

HUBBELL CATALOG NUMBERS										
CONFIGURATION	BLACK	BLUE	BROWN	GRAY	IVORY	LT. ALMOND	RED	WHITE	GREEN	ORANGE
15A/125V	5262STBKTR	5262STBLTR	5262STTR	5262STGYTR	5262STITR	5262STLATR	5262STRTR	5262STWTR	5262STGNTR	5262STOTR
20A/125V	5362STBKTR	5362STBLTR	5362STTR	5362STGYTR	5362STITR	5362STLATR	5362STRTR	5362STWTR	5362STGNTR	5362STOTR

GENERAL NOTES:

1. DIMENSIONS ARE IN INCHES [MM].
2. ALL DEVICES UL LISTED, CSA & FED. SPEC. CERTIFIED
3. TERMINALS ACCOMMODATE #14 - #10 AWG COPPER WIRE ONLY.

CAGE CODE 74545

1	INITIAL RELEASE PER DCN 221107025442 SIV	WHD	11/23/22
REV	DESCRIPTION	APP	DATE

THE DESIGN AND DIMENSIONS OF THE PRODUCT SHOWN ON THIS DRAWING ARE SUBJECT TO CHANGE WITHOUT NOTICE. DIMENSIONS ARE IN INCHES [mm].

TITLE
 DUPLEX RECEPTACLE, EdgeConnect,
 15A & 20A, TR, FED SPEC



WIRING DEVICE-KELLEMS
 HUBBELL INCORPORATED
 SHELTON, CT

TOLERANCES UNLESS OTHERWISE SPECIFIED .XX = ± .01 .XXX = ± .005 ANGLE TOL. ±2'	DR. BY SIV	SCALE 1:1
	CHK. BY WHD	DATE 06/29/22

DIMENSION SHEET FOR CAT. NO. SEE TABLE

B

M-14573

1