

M-14623

1

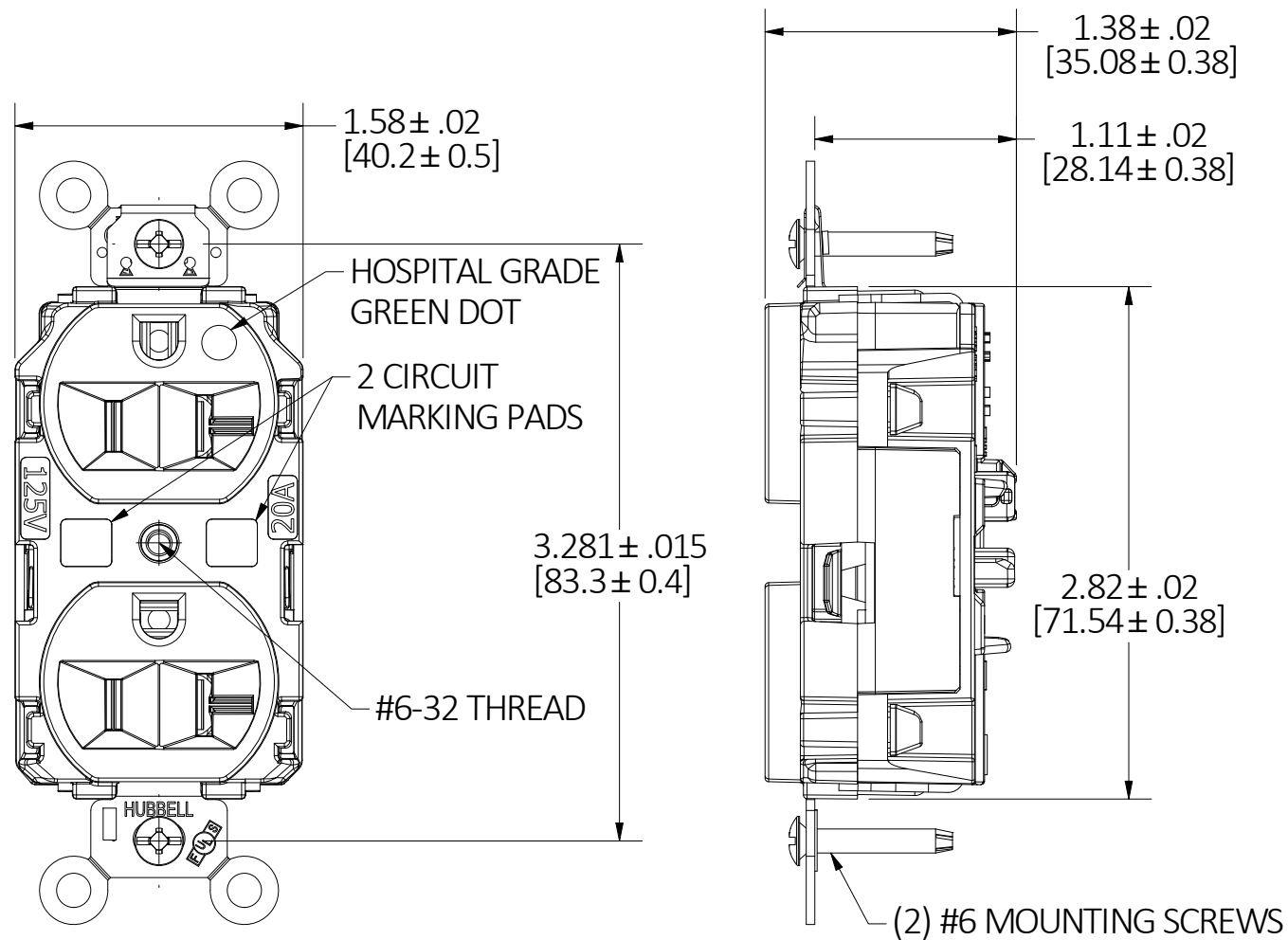

20A/125V DEVICE SHOWN

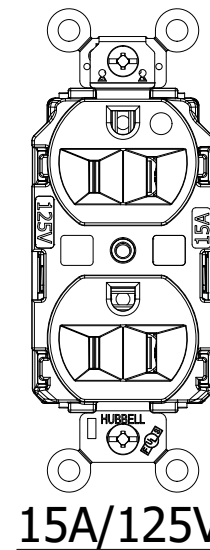

LIST OF PARTS		
DESCRIPTION	MATERIAL	FINISH
TOP COVER	PC	-
BASE	PC	-
BRIDGE	Ni PLATED BRASS	-
GROUND CONTACTS	COPPER ALLOY	-
LINE CONTACTS	COPPER ALLOY	-
REAR COVER	PC	-
PLUNGER	NYLON	-
SPRING	STAINLESS STEEL	-
AUTO GND CLIP	STAINLESS STEEL	-
WASHER	PVC FILM	BLACK
GROUND STRAP	COPPER ALLOY	-
MOUNTING SCREW	STEEL	ZINC PLATE

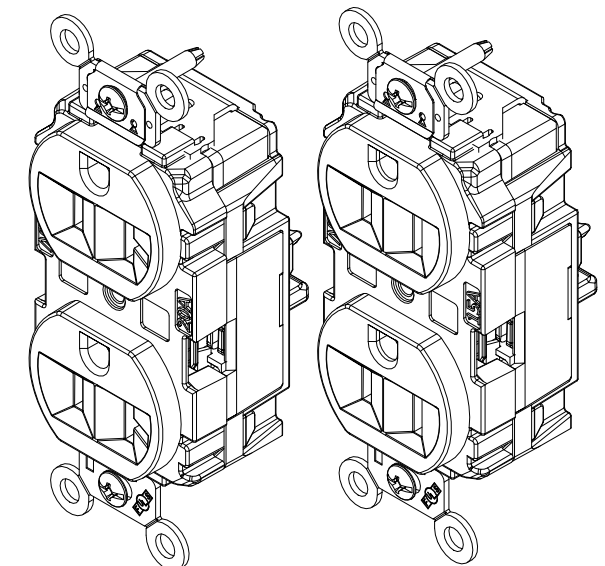

CATALOG NO: HBL8300ST (NOT SHOWN TO SCALE)

CATALOG NO: HBL8200ST (NOT SHOWN TO SCALE)

HUBBELL CATALOG NUMBERS

AMPERAGE	BLACK	BLUE	BROWN	GRAY	IVORY	LT. ALMOND	RED	WHITE	GREEN	ORANGE
15A	HBL8200STBK	HBL8200STBL	HBL8200ST	HBL8200STGY	HBL8200STI	HBL8200STLA	HBL8200STR	HBL8200STW	HBL8200STGN	HBL8200STO
20A	HBL8300STBK	HBL8300STBL	HBL8300ST	HBL8300STGY	HBL8300STI	HBL8300STLA	HBL8300STR	HBL8300STW	HBL8300STGN	HBL8300STO

GENERAL NOTES:

- DIMENSIONS ARE IN INCHES [MM].
- ALL DEVICES UL LISTED, CSA & FED. SPEC. CERTIFIED
- TERMINALS ACCOMMODATE #14 - #10 AWG COPPER WIRE ONLY.

CAGE CODE 74545

1	RELEASED PER DCN 221107025442 SIV WHD	WHD	11/07/22
REV	DESCRIPTION	APP	DATE

THE DESIGN AND DIMENSIONS OF THE PRODUCT SHOWN ON THIS DRAWING ARE SUBJECT TO CHANGE WITHOUT NOTICE. DIMENSIONS ARE IN INCHES [mm].

TITLE DUPLEX RECEPTACLE, EdgeConnect, 15A & 20A, FINDER FACE, HOSPITAL GRADE



WIRING DEVICE-KELLEMS
HUBBELL INCORPORATED
SHELTON, CT

TOLERANCES UNLESS OTHERWISE SPECIFIED
.XX = ± .01
.XXX = ± .005
ANGLE TOL. ±2°

DR. BY SIV	SCALE 1:1
CHK. BY WHD	DATE 06/28/22

DIMENSION SHEET FOR CAT. NO. SEE TABLE

B

M-14623

1