

M-14624

1

1.58 ± .02
[40.2 ± 0.5]

1.38 ± .02
[35.1 ± 0.5]

1.11 ± .02
[28.32 ± 0.38]

3.281 ± .015
[83.3 ± 0.4]

2.82 ± .02
[71.54 ± 0.38]

CIRCUIT
MARKING PAD

#6-32 THREAD

(2) #6 MOUNTING SCREWS

20A/125V DEVICE SHOWN

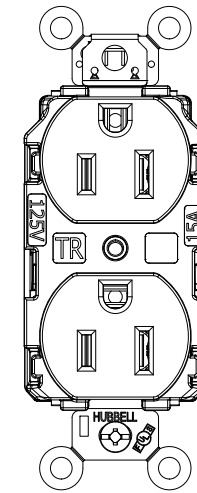

15A/125V

LIST OF PARTS

DESCRIPTION	MATERIAL	FINISH
TOP COVER	PC	-
BASE	PC	-
BRIDGE	BRASS	-
GROUND CONTACTS	COPPER ALLOY	-
LINE CONTACTS	COPPER ALLOY	-
REAR COVER	PC	-
PLUNGER	NYLON	-
SPRING	STAINLESS STEEL	-
AUTO GND CLIP	STAINLESS STEEL	-
WASHER	PVC FILM	BLACK
GROUND STRAP	COPPER ALLOY	-
MOUNTING SCREW	STEEL	ZINC PLATE

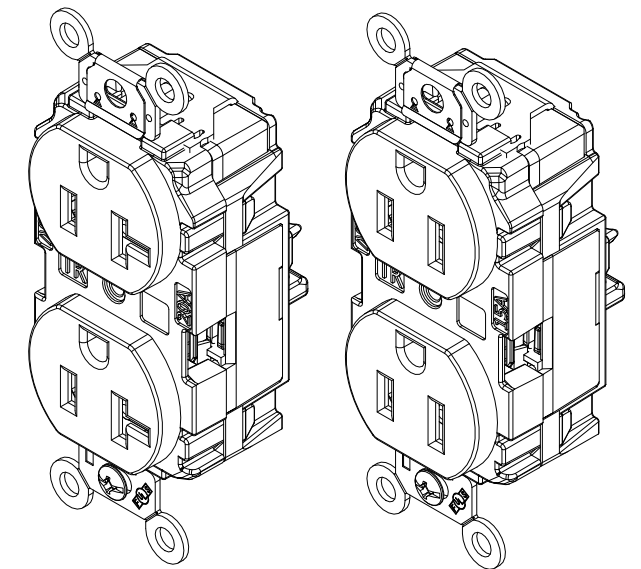

CATALOG NO: HBL5362STTR (NOT SHOWN TO SCALE) CATALOG NO: HBL5262STTR (NOT SHOWN TO SCALE)

HUBBELL CATALOG NUMBERS

AMPERAGE	BLACK	BLUE	BROWN	GRAY	IVORY
15A	HBL5262STBKTR	HBL5262STBLTR	HBL5262STTR	HBL5262STGYTR	HBL5262STITR
20A	HBL5362STBKTR	HBL5362STBLTR	HBL5362STTR	HBL5362STGYTR	HBL5362STITR
	LT. ALMOND	RED	WHITE	GREEN	ORANGE
15A	HBL5262STLATR	HBL5262STRTR	HBL5262STWTR	HBL5262STGNTR	HBL5262STOTR
20A	HBL5362STLATR	HBL5362STRTR	HBL5362STWTR	HBL5362STGNTR	HBL5362STOTR

GENERAL NOTES:

1. DIMENSIONS ARE IN INCHES [MM].
2. ALL DEVICES UL LISTED, CSA & FED. SPEC. CERTIFIED
3. TERMINALS ACCOMMODATE #14 - #10 AWG COPPER WIRE ONLY.

CAGE CODE 74545

1	RELEASED PER DCN 221107025442 SIV WHD	WHD	11/07/22
REV	DESCRIPTION	APP	DATE

THE DESIGN AND DIMENSIONS OF THE PRODUCT SHOWN ON THIS DRAWING ARE SUBJECT TO CHANGE WITHOUT NOTICE. DIMENSIONS ARE IN INCHES [mm].

TITLE
INDUSTRIAL
DUPLEX RECEPTACLE, EdgeConnect,
15A & 20A, TR, FED SPEC



WIRING DEVICE-KELLEMS
HUBBELL INCORPORATED
SHELTON, CT

TOLERANCES UNLESS OTHERWISE SPECIFIED .XX = ± .01 .XXX = ± .005 ANGLE TOL. ±2'	DR. BY SIV	SCALE 1:1
	CHK. BY WHD	DATE 06/28/22

DIMENSION SHEET FOR CAT. NO. SEE TABLE

B

M-14624

1