

M-14630

2

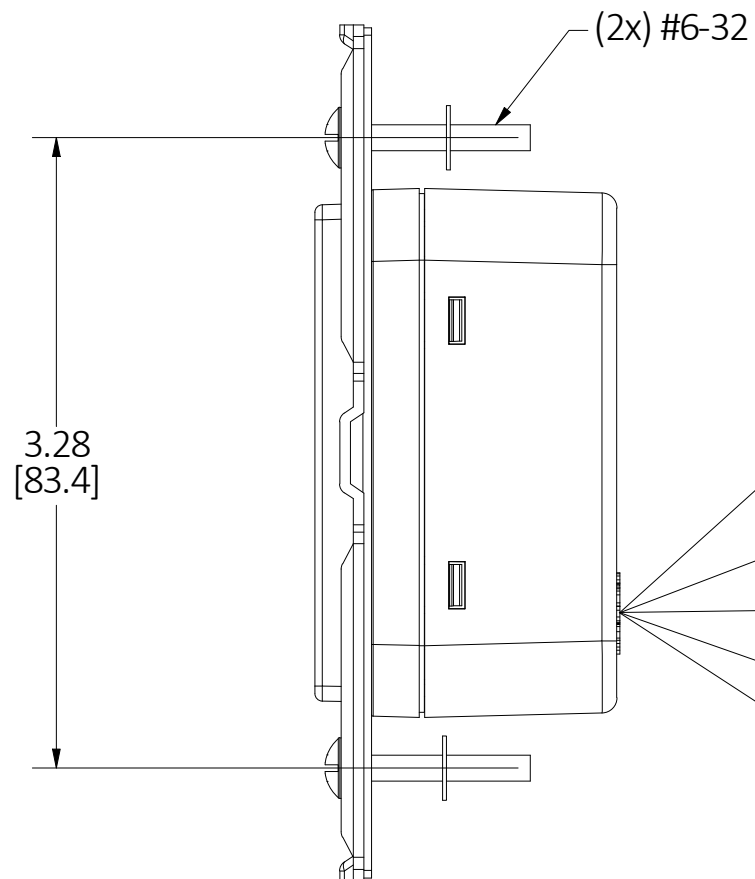

6" LONG LEAD WIRES:  
 #16 AWG, BLACK  
 #16 AWG, RED  
 #14 AWG, GREEN  
 #16 AWG, WHITE  
 #16 AWG, YELLOW

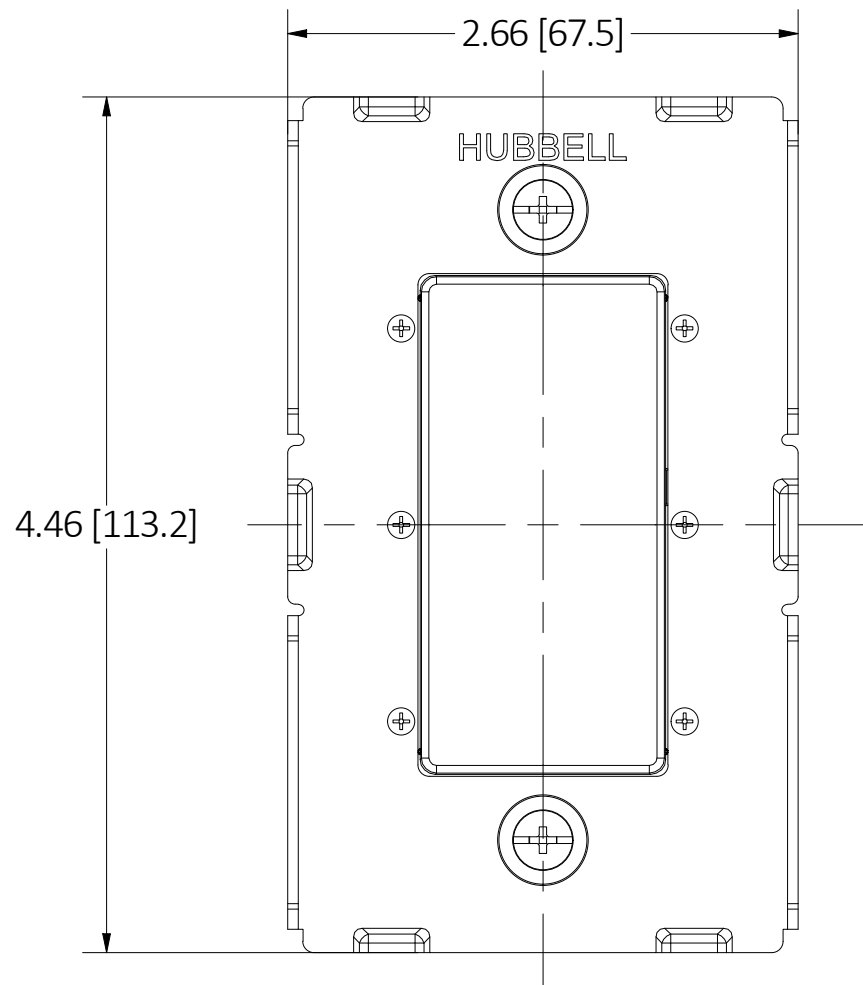
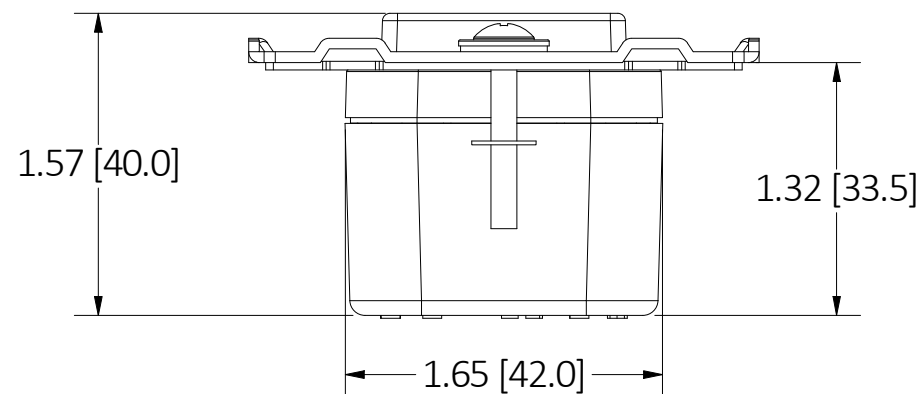

**NOTES:**

1. ALL DIMENSIONS ARE IN INCHES [mm].
2. INPUT: 120-277Vac 60Hz  
 LOAD: 120Vac, 5A ELECTRONIC BALLAST CFL/LED.  
 120Vac, 10A STANDARD BALLAST.  
 120Vac, 10A 1,200W TUNGSTEN, ½ HP Motor.  
 277Vac, 8A STANDARD BALLAST.
3. COMPATIBLE WITH COMMON LIGHTING LOADS SUCH AS LED, INCANDESCENT, ELECTRICAL/MAGNETIC FLUORESCENT.

CAGE CODE 74545

LIST OF PARTS

DESCRIPTION	MATERIAL	FINISH
YOKE	STEEL	Zn PLATE
BASE	THERMOPLASTIC	WHITE
COVER	THERMOPLASTIC	WHITE
MOUNTING SCREW	STEEL	Zn PLATE

2	"60Hz" WAS "50/60Hz" PER DCN#221201026052	D.LI	12/1/22
1	NEW RELEASE PER DCN #220920024204	D.LI	7/29/22
REV	DESCRIPTION	APP	DATE

THE DESIGN AND DIMENSIONS OF THE PRODUCT SHOWN ON THIS DRAWING ARE SUBJECT TO CHANGE WITHOUT NOTICE. DIMENSIONS ARE IN INCHES [mm].

TITLE

SP/3- OR 4-WAY 1-G SCRUB TAP/TOUCH SWITCH, NO PLATE



WIRING DEVICE-KELLEMS  
 HUBBELL INCORPORATED  
 SHELTON, CT

TOLERANCES UNLESS OTHERWISE SPECIFIED .XX = ± .01 .XXX = ± .005 ANGLE TOL. ±2'	DR. BY D.LI	SCALE 1:1
	CHK. BY	DATE 7/29/22

DIMENSION SHEET FOR CAT. NO. MSS1277

**B**

**M-14630**

**2**