

M-14644

1

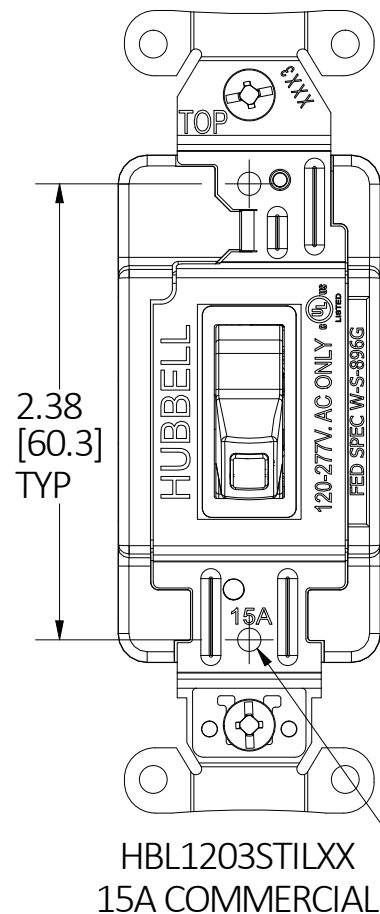

HBL1203STILXX
15A COMMERCIAL

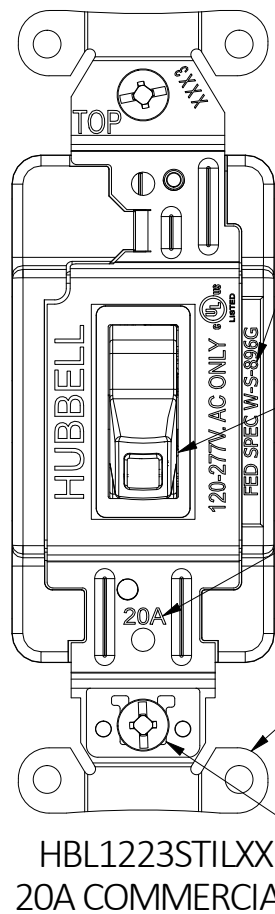

HBL1223STILXX
20A COMMERCIAL

LISTING MARKINGS
SEE NOTE 2 & 3

LED LENS

AMPERAGE
RATING

GALVANIZED
ZINC PLATE
TYP

TRI-DRIVE #6-32
MOUNTING SCREWS
(2x) TYP

2X #6-32
TAPPED HOLES
TYP

TOGGLE HANDLE
SEE TABLE 1

3.28
[83.4]

COVER

PLUNGER DOWN

1.33
[33.7]

4.18
[106.2]

1.37
[34.7]

PLUNGER UP

.76
[19.3]

1.50
[38.1]

TRAVELERS
(BLACK PLUNGER)

COMMON / DOWNSTREAM
(RED PLUNGER)

GROUND
(GREEN
PLUNGER)

HBL1223STILBK
SHOWN

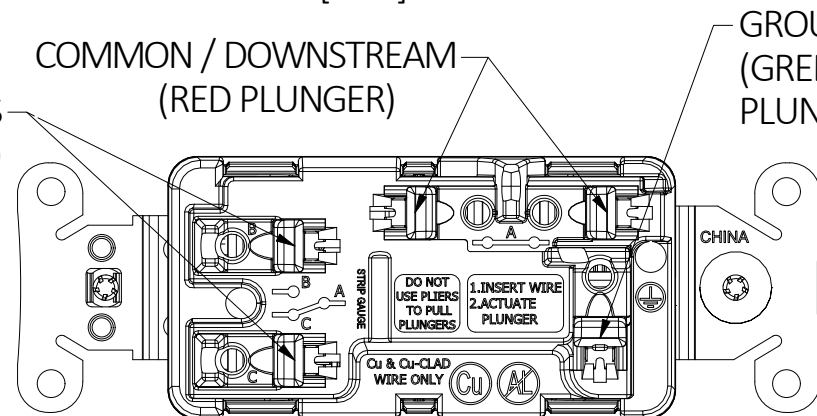

LIST OF PARTS		
DESCRIPTION	MATERIAL	FINISH
HOUSINGS	PC	---
TOGGLE/HANDLE	NYLON	---
PLUNGER	NYLON	---
BRIDGE	STEEL	NICKEL OR ZINC
SCREWS	STEEL	---
TERMINALS	BRONZE	---
CONTACTS	CU/SILVER LAMINATED	POLISHED
SPRING CLAMP	ALLOY	---
LED	---	---
RESISTOR	---	---
DIODE	---	---

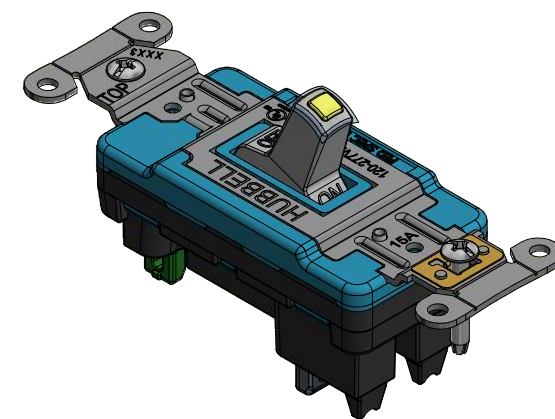

ISO VIEW
SCALE 3:4

EDGE CONNECT 3-WAY ILLUMINATED TOGGLE 120-277 VAC				
CATALOG NO.	DESCRIPTION	AMP RATING	COVER COLOR	TOGGLE COLOR
HBL1203STILXX	INDUSTRIAL	15A	BLUE	SEE TABLE 1
HBL1223STILXX	INDUSTRIAL	20A	RED	SEE TABLE 1

NOTES:

1. cULus LISTED - APPROVED IN US AND CANADA
2. MEETS UL20, UL486E, CSA C22.2 No.111 & FED SPEC W-S-896-G

TABLE 1: SUFFIX	
TOGGLE COLOR	-XX
BROWN	---
IVORY	I
GRAY	GY
WHITE	W
RED	R
BLACK	BK
LIGHT ALMOND	LA

1	RELEASE TO PRODUCTION PER EC230412029445 BP	KP	4/20/23
REV	DESCRIPTION	APP	DATE

THE DESIGN AND DIMENSIONS OF THE PRODUCT SHOWN ON THIS DRAWING ARE SUBJECT TO CHANGE WITHOUT NOTICE. DIMENSIONS ARE IN INCHES [mm].

TITLE
CUSTOMER DRAWING
3-WAY 15A/20A ILLUMINATED
EDGE CONNECT SWITCH



WIRING DEVICE-KELLEMS
HUBBELL INCORPORATED
SHELTON, CT

TOLERANCES UNLESS OTHERWISE SPECIFIED .XX = ±.01 .XXX = ±.005 ANGLE TOL. ±2'	DR. BY BP	SCALE 1:1
	CHK. BY KP	DATE 1/4/22

DIMENSION SHEET FOR CAT. NO.
SEE TABLE

B

M-14644

1