

M-14680

1

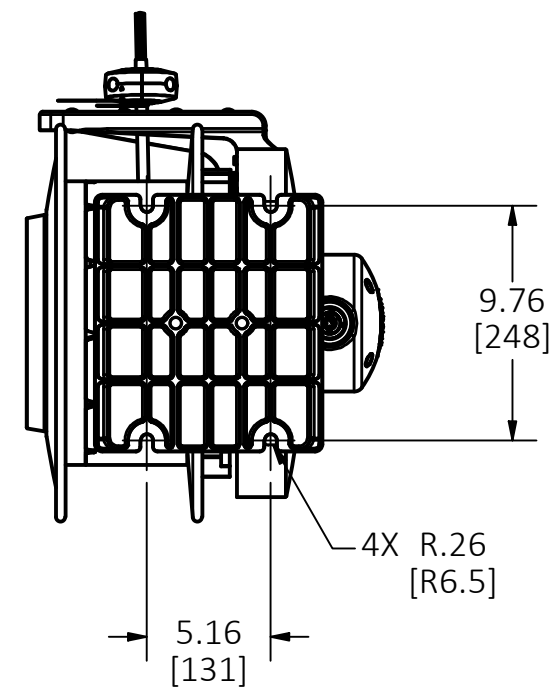

5" REEL

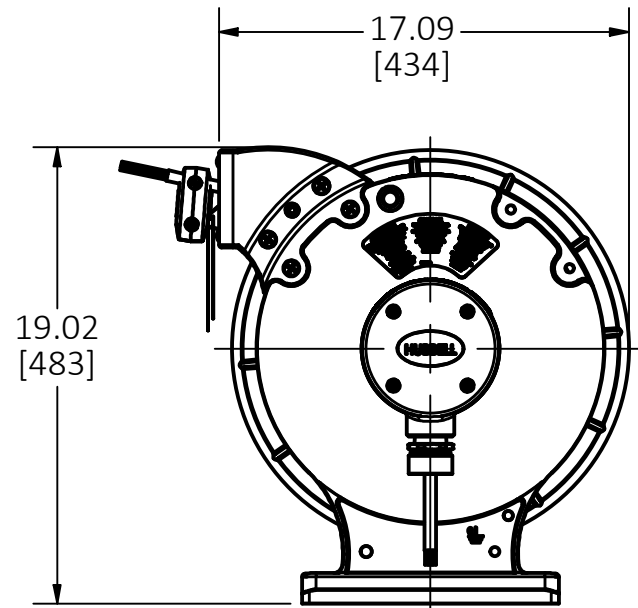
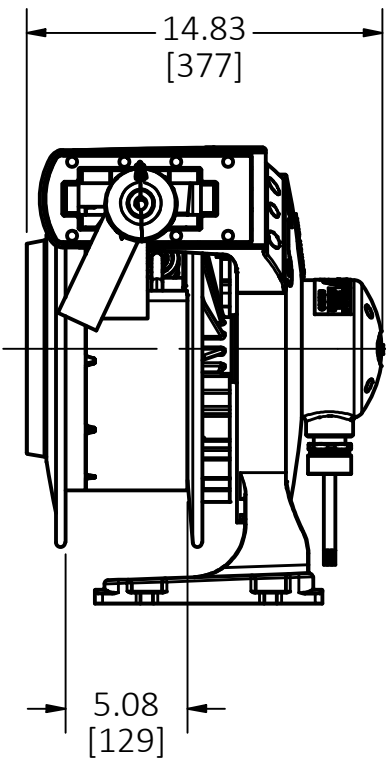
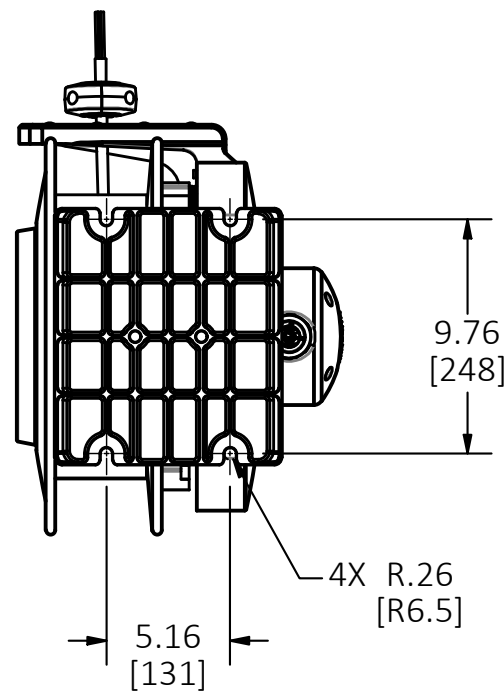
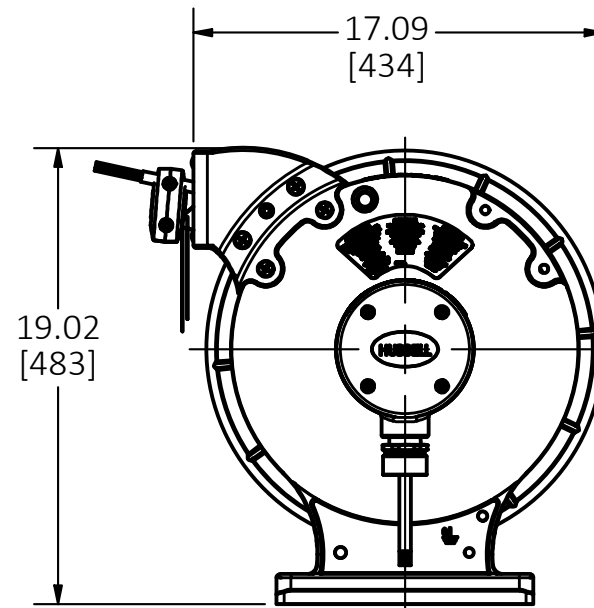
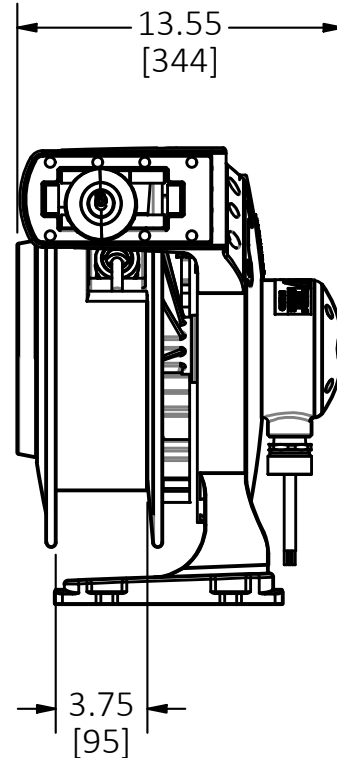

3" REEL

NOTES:

1. DIMENSIONS ARE IN INCHES [mm] EXCEPT CORD LENGTH IN FEET.

LIST OF PARTS

DESCRIPTION	MATERIAL	FINISH
SPOOL WITH RACHET	ALUMINUM	POWDER COATING
SPOOL	ALUMINUM	POWDER COATING
WIRING CHAMBER COVER	ALUMINUM	POWDER COATING
SPRING BOX COVER	STEEL	ZINC PLATE
CLOCKWORK SPRING	SPRING STEEL	
GUIDE ARM	ALUMINUM	POWDER COATING
GUIDE FRAME	THERMOPLASTIC	
HARDWARE	STEEL	ZINC PLATE
SPINDLE	STEEL	ZINC PLATE
CORD	COPPER	
BALL STOPPER	THERMOPLASTIC	
INTERNAL TERMINALS	COPPER ALLOY	
FITTING	ALUMINUM	

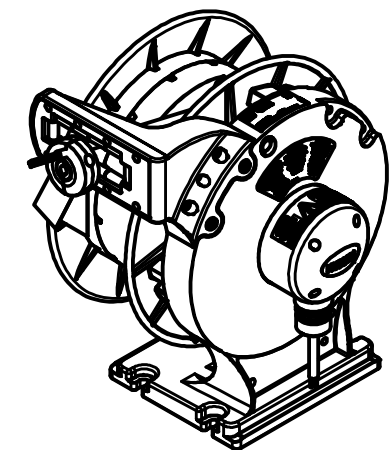

1	INITIAL RELEASE DCN 230517030326 RM	JS	6/26/23
REV	DESCRIPTION	APP	DATE

THE DESIGN AND DIMENSIONS OF THE PRODUCT SHOWN ON THIS DRAWING ARE SUBJECT TO CHANGE WITHOUT NOTICE. DIMENSIONS ARE IN INCHES [mm].

TITLE  
REEL, WITH OPEN CORD END  
UL TYPE 1 & 4



WIRING DEVICE-KELLEMS  
HUBBELL INCORPORATED  
SHELTON, CT

TOLERANCES UNLESS OTHERWISE SPECIFIED .XX = ±.01 .XXX = ±.005 ANGLE TOL. ±2'	DR. BY RM	SCALE 1/8
	CHK. BY	DATE 6/20/23

DIMENSION SHEET FOR CAT. NO. SEE TABLE

B

M-14680

1

M-14680

1

LIST OF PARTS

DESCRIPTION	MATERIAL	FINISH

CATALOG #	DESCRIPTION	RATING	CORD LENGTH	CORD TYPE	CORD COLOR	BALL STOP	REEL SIZE	REEL COLOR	APPROX. WEIGHT lb [kg]
HBLI70123	IND. REEL, UL TYPE 1, 70' SJO, 12/3 WH	18A/250V	70 FT.	12/3 SJO	BLACK	ROUND	3"	WHITE	79.64 [36.12]
HBLI80103	IND. REEL, UL TYPE 1, 80' SJO, 10/3 WH	25A/250V	80 FT.	10/3 SJO	BLACK	ROUND	5"	WHITE	104.28 [47.30]
HBLI80104	IND. REEL, UL TYPE 1, 80' SJO, 10/4 WH	20A/250V	80 FT.	10/4 SJO	BLACK	ROUND	5"	WHITE	113.30 [51.39]
HBLI80124	IND. REEL, UL TYPE 1, 80' SJO, 12/4 WH	16A/250V	80 FT.	12/4 SJO	BLACK	ROUND	3"	WHITE	76.12 [34.53]
HBLI90123	IND. REEL, UL TYPE 1, 90' SJO, 12/3 WH	18A/250V	90 FT.	12/3 SJO	BLACK	ROUND	3"	WHITE	86.46 39.22]

CATALOG #	DESCRIPTION	RATING	CORD LENGTH	CORD TYPE	CORD COLOR	BALL STOP	REEL SIZE	REEL COLOR	APPROX. WEIGHT lb [kg]
HBLW45128W	WP REEL, UL TYPE 4, 45' SOW, 12/8 WH	14A/600V	45 FT.	12/8 SOW	BLACK	SPHERE	5"	WHITE	110.44 [50.09]
HBLW451412W	WP REEL, UL TYPE 4, 45' SOW, 14/12 WH	6A/600V	45 FT.	14/12 SOW	BLACK	SPHERE	5"	WHITE	113.52 [51.49]
HBLW4563W	WP REEL, UL TYPE 4, 45' SOW, 6/3 WH	55A/600V	45 FT.	6/3 SOW	BLACK	SPHERE	5"	WHITE	122.98 [55.78]
HBLW4564W	WP REEL, UL TYPE 4, 45' SOW, 6/4 WH	55A/600V	45 FT.	6/4 SOW	BLACK	SPHERE	5"	WHITE	126.72 [57.48]
HBLW4583W	WP REEL, UL TYPE 4, 45' SOW, 8/3 WH	40A/600V	45 FT.	8/3 SOW	BLACK	SPHERE	5"	WHITE	106.48 [48.30]
HBLW4584W	WP REEL, UL TYPE 4, 45' SOW, 8/4 WH	35A/600V	45 FT.	8/4 SOW	BLACK	SPHERE	5"	WHITE	122.76 [55.68]
HBLW6083W	WP REEL, UL TYPE 4, 60' SOW, 8/3 WH	30A/600V	60 FT.	8/3 SOW	BLACK	SPHERE	5"	WHITE	123.20 [55.88]
HBLW75103W	WP REEL, UL TYPE 4, 75' SOW, 10/3 WH	25A/600V	75 FT.	10/3 SOW	BLACK	ROUND	5"	WHITE	103.84 [47.10]
HBLW75104W	WP REEL, UL TYPE 4, 75' SOW, 10/4 WH	20A/600V	75 FT.	10/4 SOW	BLACK	SPHERE	5"	WHITE	116.16 [52.69]
HBLW75124W	WP REEL, UL TYPE 4, 75' SOW, 12/4 WH	16A/600V	75 FT.	12/4 SOW	BLACK	ROUND	5"	WHITE	107.36 [48.70]
HBLW80123W	WP REEL, UL TYPE 4, 80' SOW, 12/3 WH	18A/600V	80 FT.	12/3 SOW	BLACK	ROUND	5"	WHITE	97.46 [44.21]

1	INITIAL RELEASE DCN 230517030326 RM	JS	6/26/23
REV	DESCRIPTION	APP	DATE

THE DESIGN AND DIMENSIONS OF THE PRODUCT SHOWN ON THIS DRAWING ARE SUBJECT TO CHANGE WITHOUT NOTICE. DIMENSIONS ARE IN INCHES [mm].

TITLE  
REEL, WITH OPEN CORD END  
UL TYPE 1 & 4

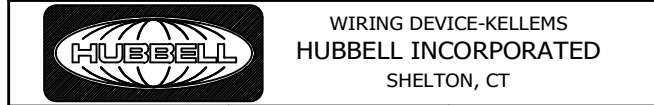

TOLERANCES UNLESS OTHERWISE SPECIFIED .XX = ± .01 .XXX = ± .005 ANGLE TOL. ±2'	DR. BY RM	SCALE
	CHK. BY	DATE 6/20/23

CATALOG #	DESCRIPTION	APPROX. WEIGHT lb [kg]
HBLIACCBS	REEL, REPL. ROUND BALL STOP	0.3 [0.14]
HBLWACCBS	REEL REPL. SPHERICAL BALL STOP	0.4 [0.18]

CAGE CODE 74545

DIMENSION SHEET FOR CAT. NO. B M-14680 1