

CUSTOMER APPROVAL
 APPROVED BY: _____
 DATE: _____

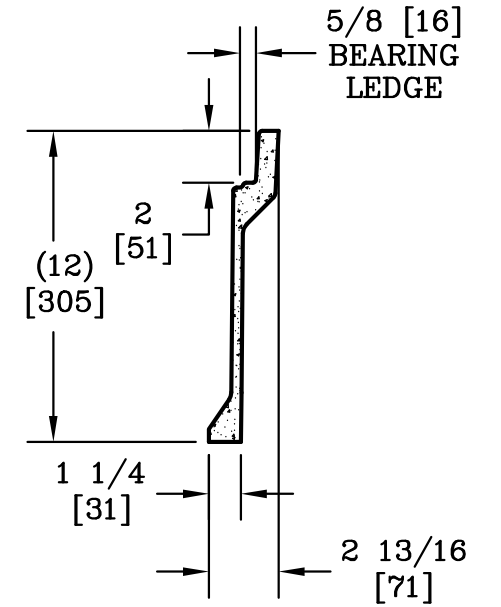

SECTION A-A

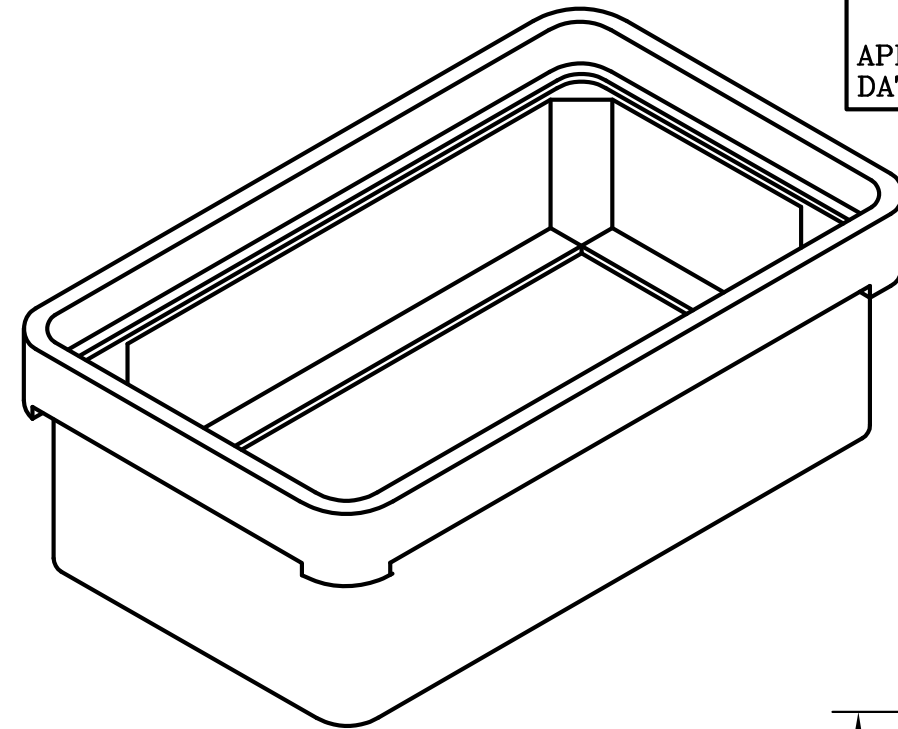
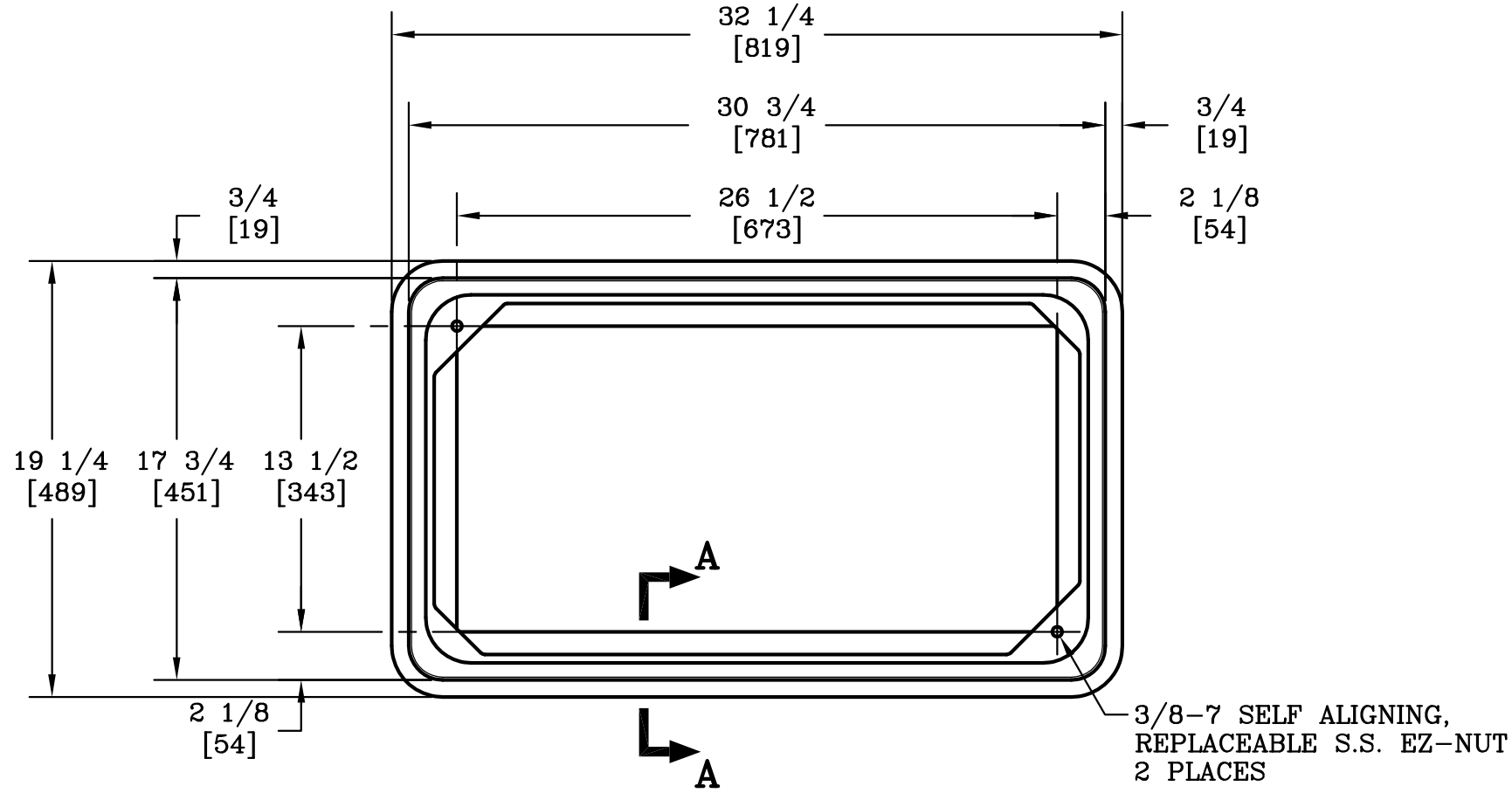
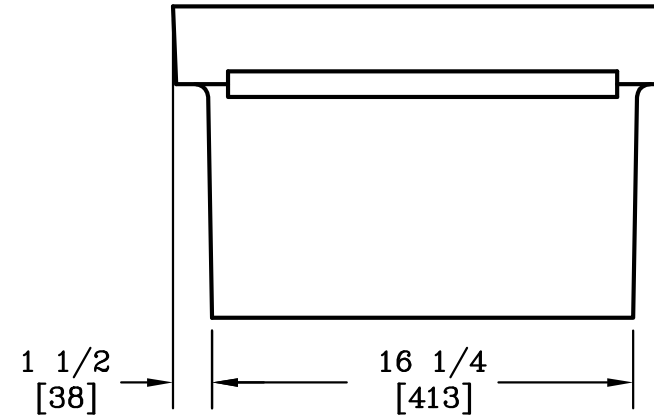
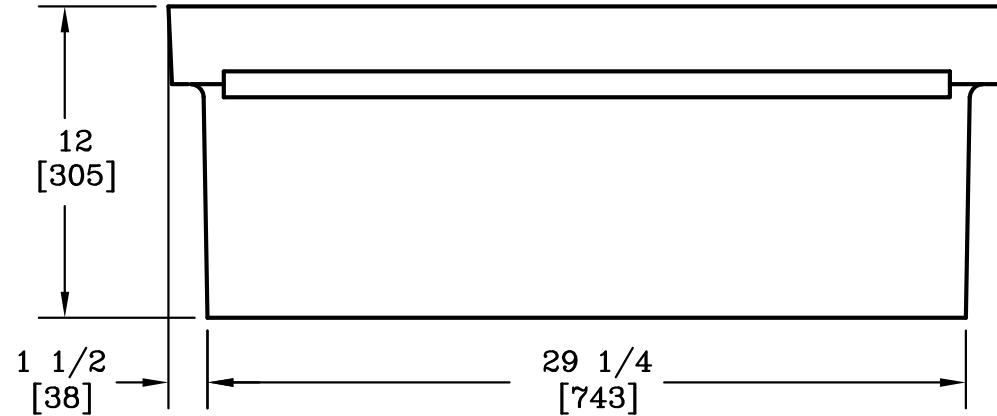

NOTE:

1. THIS BOX IS RATED FOR ANSI/SCTE 77 2010 TIER 22.



DIMENSIONS ARE IN INCHES OR MILLIMETERS IN BRACKETS UNLESS OTHERWISE NOTED.				3621 INDUSTRIAL PARK DR LENOIR CITY, TN 37771 800-346-3062 www.quazite.com	LOC
DRN	BY	DATE	WEIGHT		LC
CHK	ENG	SCALE	66# 30kg	S	
APR	APR	SIZE	1 1/2"=1'	REV	
APR		B		D	
PROJECT NUMBER				DRAWING NUMBER	
93747				PG1730BA12	
SHEET 1 OF 1					