

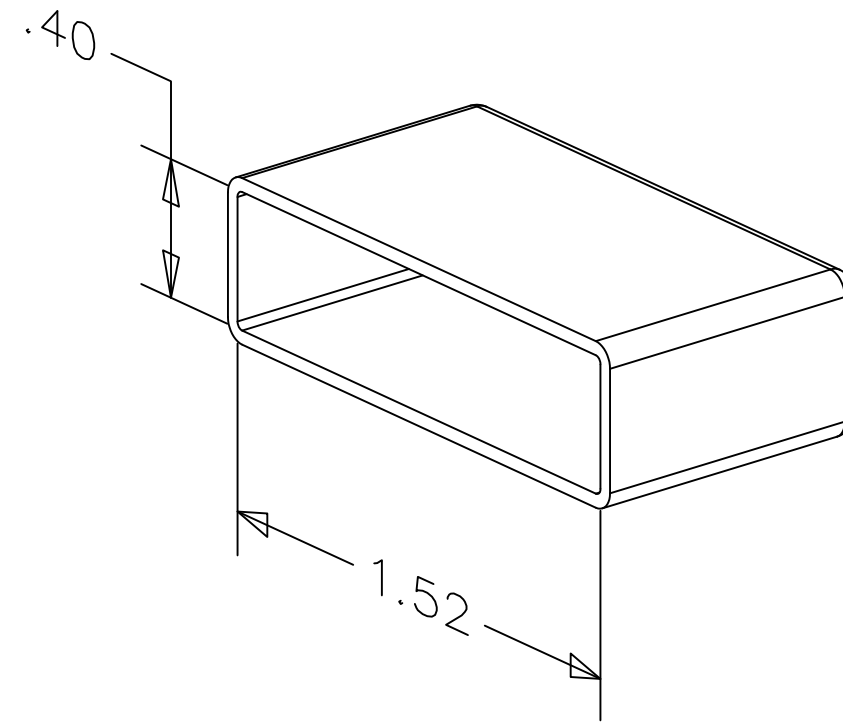

| | |
|-------------|--------------------------------------|
| CATALOG NO. | DESCRIPTION |
| HLECPK2 | PROTECTIVE CAPS FOR LADDER RACK ENDS |

NOTES:

1. END PROTECTIVE CAPS ARE USED TO COVER EXPOSED END OF THE LADDER RACK.
2. KIT CONTAINS:
 - (2) END CAPS
 - (1) INSTRUCTION SHEET P/N 77896801
3. SPECIFICATIONS SUBJECT TO CHANGE WITHOUT PRIOR NOTICE.



| | | | | | |
|-----------------------------|------------------------------------------------------------------------------------------------------------------------------------------------------------------------------------------------------------------------|----------------------------------------------------------------------------------------------------------------------------------------------------------------------------------------------------------------------------------------------------|-------------------------------------------|--------------------------------------------------------------------------------------------------------------------------------------------------------------------------------------------|--------------|
| Created on V-13 UNIGRAPHICS | DIMENSIONING AND TOLERANCING PER ANSI Y14.5M-1982 UNLESS OTHERWISE SPECIFIED, DIMENSIONS ARE IN INCHES [MM]. TOLERANCES .xx = ±.01 [.] .xxx = ±.005 [.] .xxxx = ±.0025 [.] ANGLE TOL ±1° | PROJECT REFERENCE: PMS 492 | |  Hubbell Premise Wiring HUBBELL INCORPORATED (Delaware) 23 Clara Dr., Mystic, Connecticut 06355 | |
| | MATERIAL: BLACK THERMOPLASTIC RUBBER | | TITLE: LADDER RACK END PROTECTIVE CAPS | | |
| | DRAWN BY: J. RUOT-JACKSON 8/19/2016 | | SIZE: B | DRAWING NO. 11262C | REV. 1 |
| | CHECKED BY: | | SCALE: SCALE | | SHEET 1 OF 1 |
| APPROVED BY: | | IN ACCEPTING OUR DRAWINGS, BLUEPRINTS, OR SUPPORTING DOCUMENTATION FOR QUOTATION OR OTHER PURPOSES, YOU AGREE NOT TO DISCLOSE TO OTHERS THE IDEAS, INFORMATION, OR DESIGNS SHOWN HEREIN, AND THAT YOU WILL MAKE NO USE OF SAME WITHOUT PERMISSION. | | | |

| | | | | | |
|------|-------|----------|-----------------|--------|---------|
| 1 | 21405 | 08/19/16 | INITIAL RELEASE | JJRJ | MMA |
| REV. | ECN | DATE | DESCRIPTION | CHG BY | APPD BY |