

CATALOG NO.
VCJK

ITEM	DESCRIPTION	QTY
1	PLATE	1
2	#12-24 X 5/8 PAN HEAD PHILIPS SCREW	4
3	#12 FLAT WASHER	4
4	1/2-13 X 1" HEX HEAD BOLT	4
5	1/2-13 HEX NUT	4
6	1/2" FLAT WASHER	4

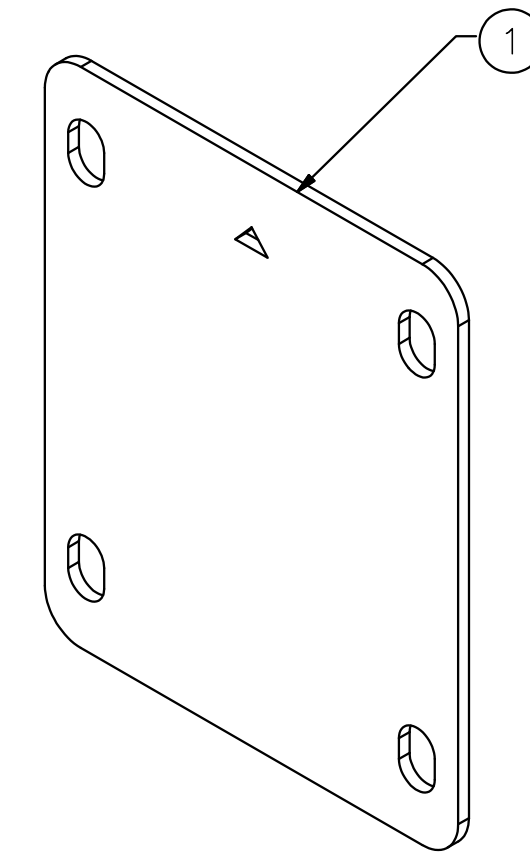
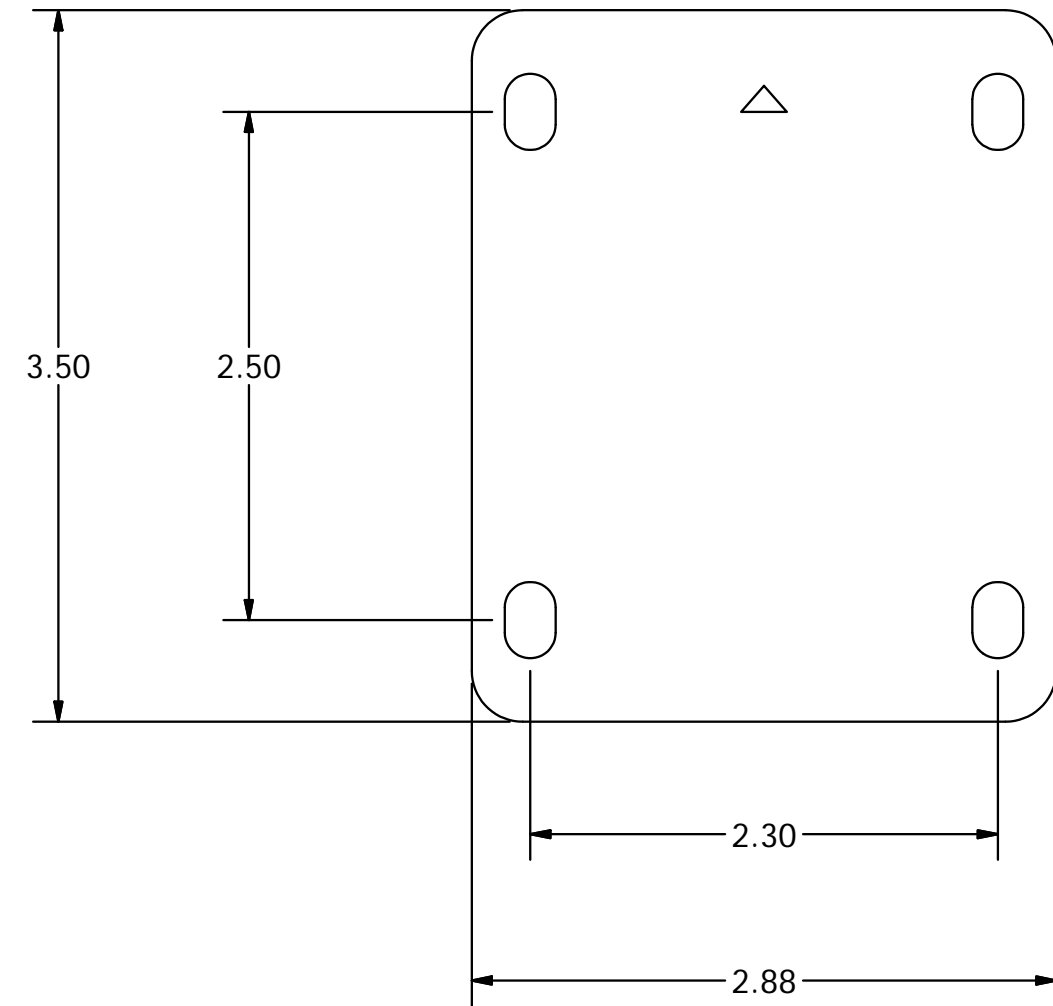

NOTES:

1. SURFACE FINISH: BLACK POWDER COAT
2. SPECIFICATIONS SUBJECT TO CHANGE WITHOUT NOTICE.

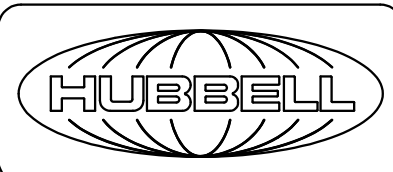

REV.	ECN	DATE	DESCRIPTION	CHG BY	APPD BY
1	21405	03/02/16	INITIAL RELEASE	MMA	DO

Created on INVENTOR	DIMENSIONING AND TOLERANCE PER ANSI Y14.5M-1982 UNLESS OTHERWISE SPECIFIED, DIMENSIONS ARE IN INCHES (MM). TOLERANCES.XX = ±.01 (.25) .XXX = ±.005 (.127) .XXXX = ±.0025 (.0635) ANGLE TOL ±1°		PROJECT REFERENCE:		
	MATERIAL:		CRS		
	DRAWN BY:		MABBY 03/02/16		
	CHECKED BY:				
APPROVED BY:				 Hubbell Premise Wiring HUBBELL INCORPORATED (Delaware) 23 CLARA DRIVE, SUITE 103 MYSTIC, CT 06355	
TITLE:		VERTICAL CHANNEL JOINING KIT			
SIZE	DRAWING NO.			REV.	
C	11483C			1	
SCALE:		N/A	SHEET 1 OF 1		