

SPECIFICATIONS:	
MADE IN USA	YES
AC RATING VOLTS	250
AC RATING AMPS	60
AC RATING WATTS	15000
AC RATING FREQUENCY	50/60 Hz
OVER CURRENT PROTECTION	(3) 2 POLE - 20 AMP MAGNETIC BREAKERS
POWER SWITCH	BREAKER/SWITCH COMBINATION
INDICATORS - POWER ON LED	3-RED LEDs INDICATE POWER ON
POWER CABLE AWG	4/3 SO
CORD LENGTH	10FT
PLUG TYPE	IEC 60309 - 2 POLE/3 WIRE, 60A, SINGLE PHASE PIN AND SLEEVE CONNECTOR
RECEPTACLES TYPE	IEC320 C-19
RECEPTACLES STYLE	INDIVIDUAL
RECEPTACLES ON REAR	3
MAXIMUM OUTPUT PER RECEPTACLE	20A
FLUSH MOUNT	OPTIONAL
19" RECESS MOUNT	OPTIONAL
PANEL MOUNT	OPTIONAL
ADJUSTABLE MOUNT	YES
CERTIFICATION/AGENCY APPROVALS	UL & c-UL LISTED 60950
UNIT WEIGHT	13 LBS

CATALOG NUMBER	DESCRIPTION
PR0360	19" RACKMOUNT POWERSTRIP, BLACK, 3 OUTLET

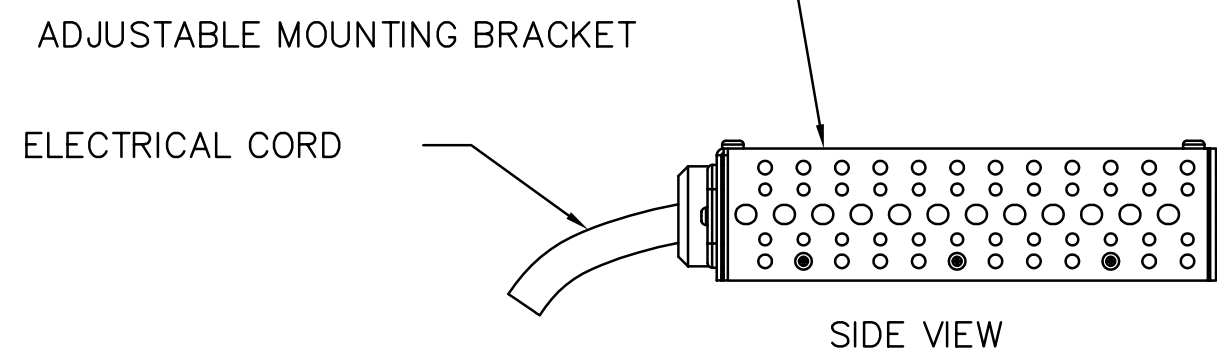
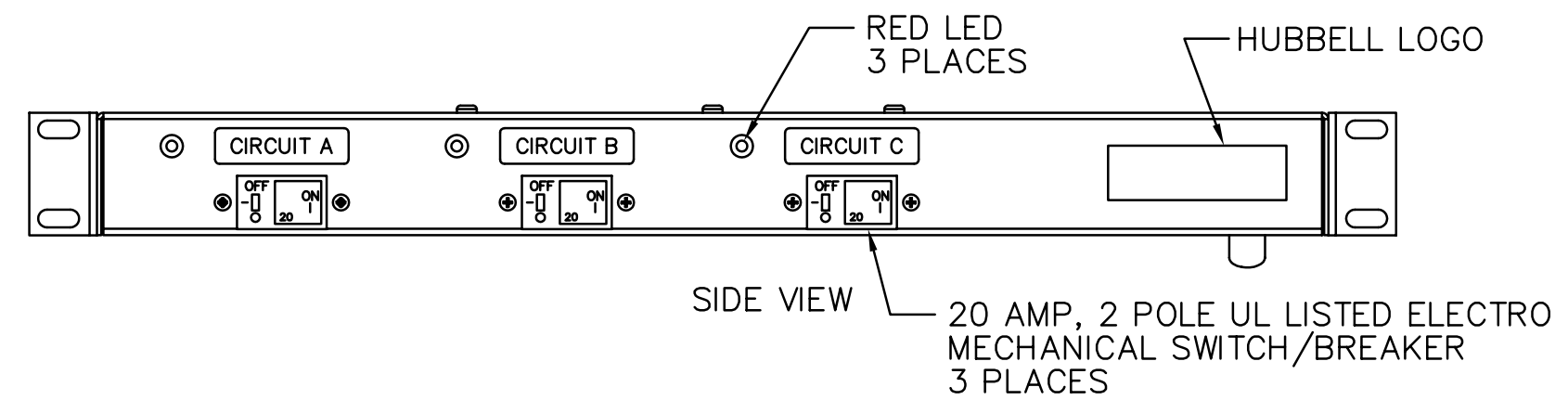
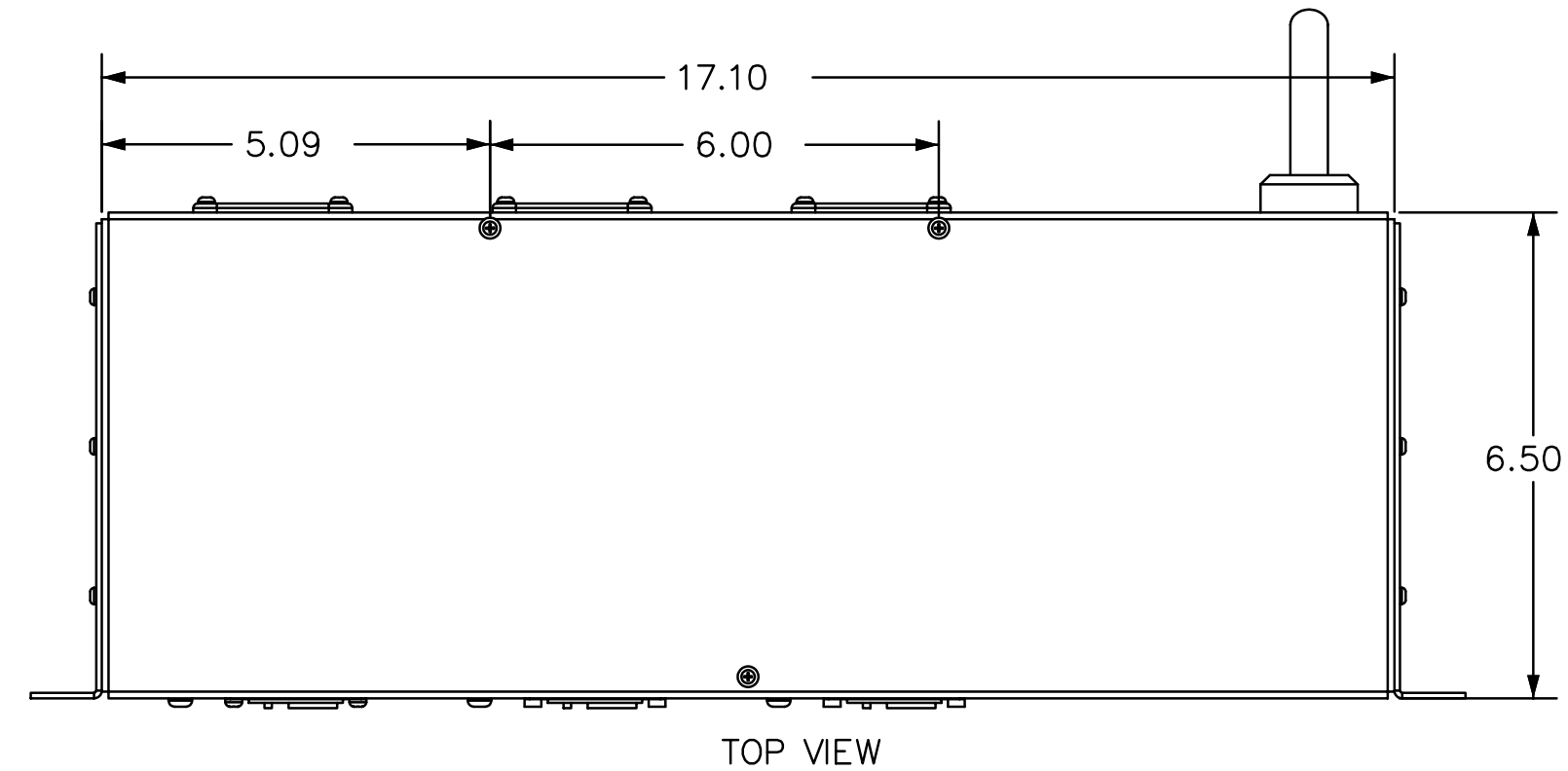
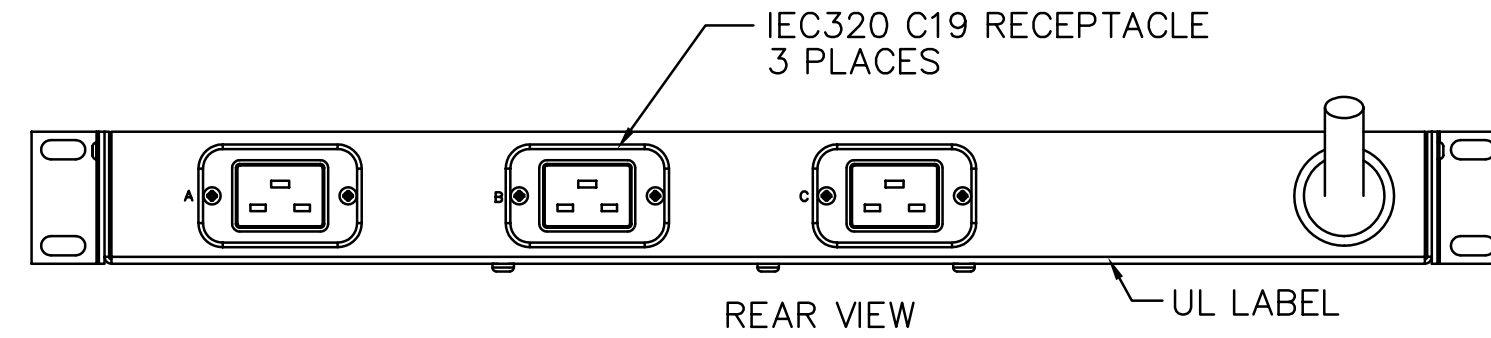

NOTES:

- KIT SHOULD CONTAIN:
 - POWER STRIP PER TABULATED SPECIFICATIONS.
 - ADJUSTABLE MOUNTING BRACKETS
 - HARDWARE PACK - MOUNTING SCREWS, BAGGED W/WASHER
 - INSTALLATION INSTRUCTIONS
- SURFACE FINISH: BLACK
- SPECIFICATIONS SUBJECT TO CHANGE WITHOUT NOTICE

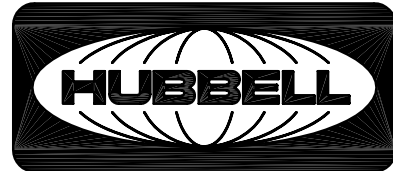
Created on AUTOCAD	DIMENSIONING AND TOLERANCE PER ANSI Y14.5M-1982 UNLESS OTHERWISE SPECIFIED, DIMENSIONS ARE IN INCHES (MM). TOLERANCES .XX = ±.01 (.25) .XXX = ±.005 (.127) .XXXX = ±.0025 (.0635) ANGLE TOL ±1°		PROJECT REFERENCE: 2004-112		 Hubbell Premise Wiring HUBBELL INCORPORATED (Delaware) 14 Lord's Hill Road, Stonington, Connecticut 06378	
			MATERIAL: HEAVY STEEL			
	IN ACCEPTING OUR DRAWINGS, BLUEPRINTS, OR SUPPORTING DOCUMENTATION FOR QUOTATION OR OTHER PURPOSES, YOU AGREE NOT TO DISCLOSE TO OTHERS THE IDEAS, INFORMATION, OR DESIGNS SHOWN HEREIN, AND THAT YOU WILL MAKE NO USE OF SAME WITHOUT PERMISSION		DRAWN BY: GLEN P. EIGO, 8/9/04		TITLE: 12" RACKMOUNT POWER STRIP, BLACK NON-SURGE PROTECTED 3 OUTLETS - 60A, 250VAC	
			CHECKED BY: DAVE MCBAIN, 8/16/04		SIZE: C	
		APPROVED BY: NATE HERRING, 8/16/04		DRAWING NO. C12020		
				REV. A		
				SCALE: NTS SHEET 1 OF 1		

REV.	ECN	DATE	DESCRIPTION	CHG BY	APPD BY
A	5390	8/9/04	INITIAL RELEASE	GPE	NJH