

6

5

4

3

2

1

CATALOG NO.	DESCRIPTION
AM0BL10	AM0 BLANK ADAPTER BRACKET HOUSING, 10 PK

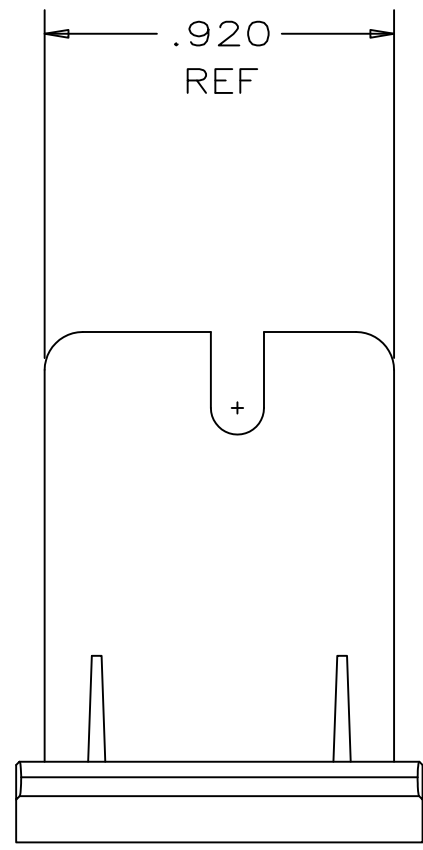

- NOTES:
- FOR USE WITH CATALOG NO. AM0, BASE UNIT HOUSING/MULTIMEDIA BOXES
 - COLOR: OFFICE WHITE
 - SPECIFICATIONS SUBJECT TO CHANGE WITHOUT PRIOR NOTICE.

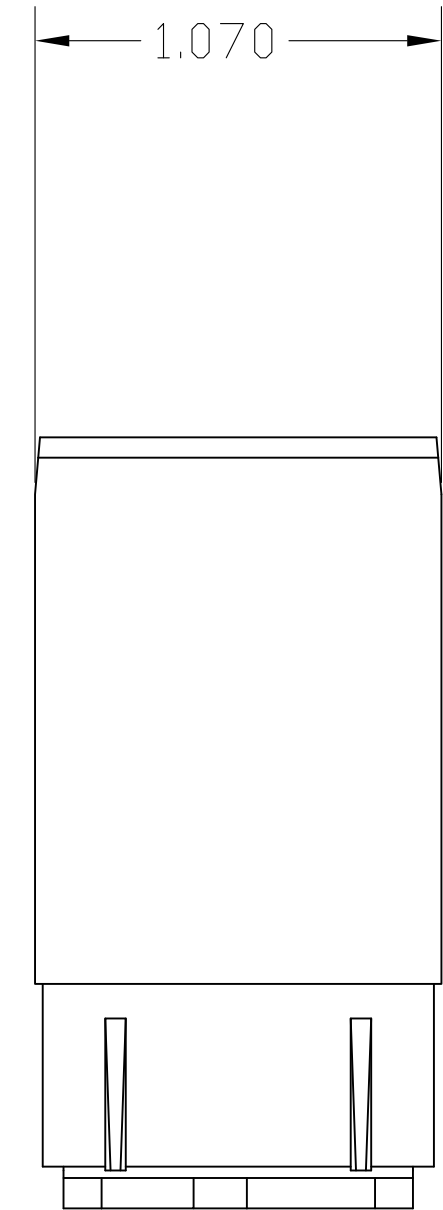
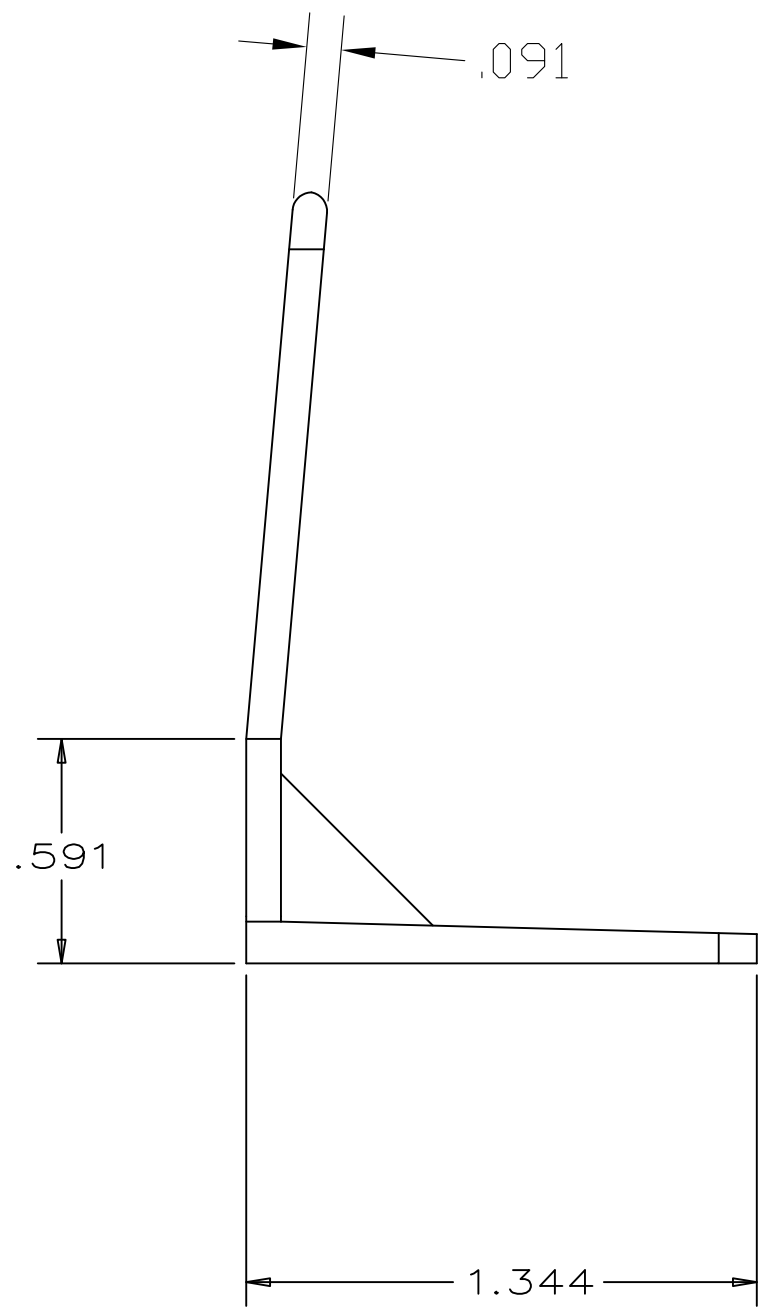
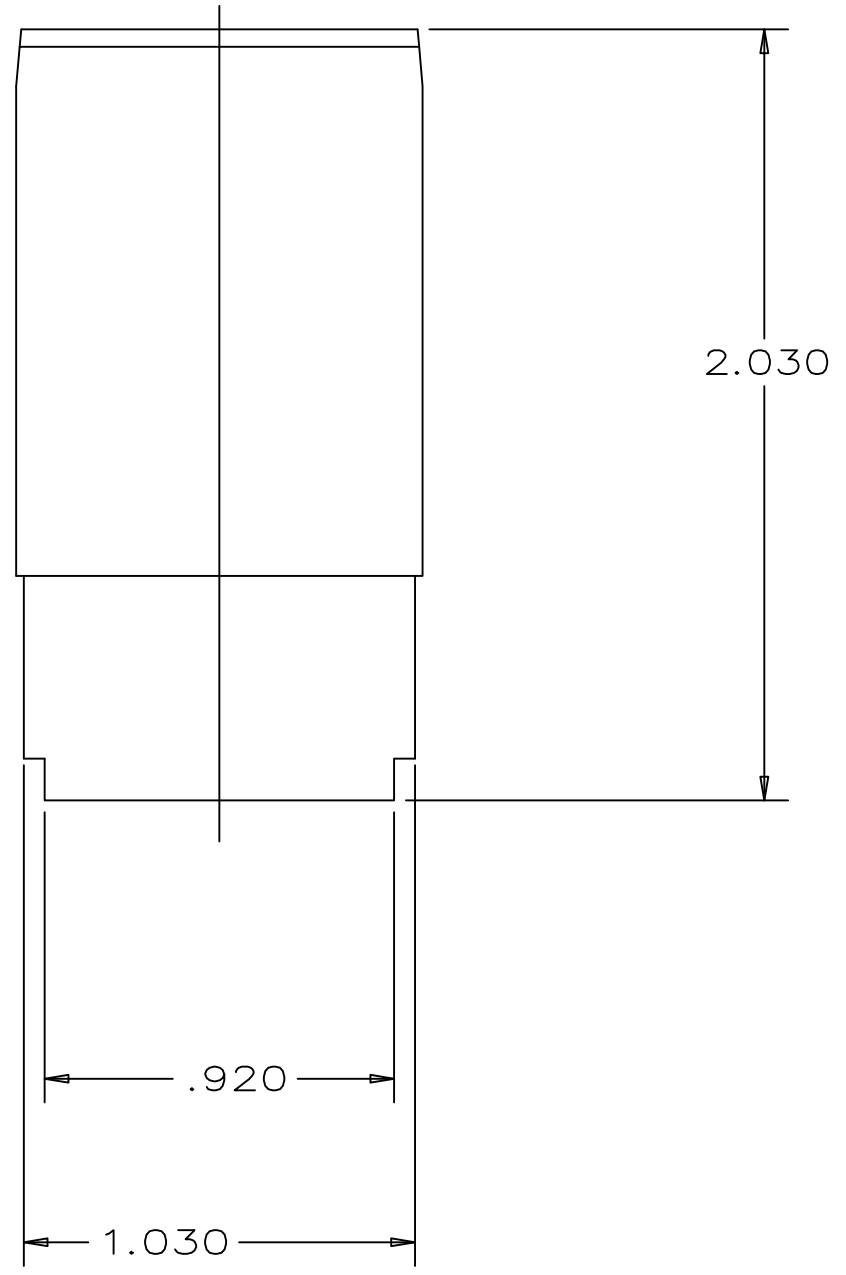

Created on AUTOCAD	DIMENSIONING AND TOLERANCE PER ANSI Y14.5M-1982 UNLESS OTHERWISE SPECIFIED, DIMENSIONS ARE IN INCHES (MM). TOLERANCES .XX = ±.01 (.25) .XXX = ±.005 (.127) .XXXX = ±.0025 (.0635) ANGLE TOL ±1°		PROJECT REFERENCE: MATERIAL: POLYCARBONATE		 Hubbell Premise Wiring HUBBELL INCORPORATED (Delaware) 14 Lord's Hill Road, Stonington, Connecticut 06378		
	IN ACCEPTING OUR DRAWINGS, BLUEPRINTS, OR SUPPORTING DOCUMENTATION FOR QUOTATION OR OTHER PURPOSES, YOU AGREE NOT TO DISCLOSE TO OTHERS THE IDEAS, INFORMATION, OR DESIGNS SHOWN HEREIN, AND THAT YOU WILL MAKE NO USE OF SAME WITHOUT PERMISSION		DRAWN BY: J. Ruot-Jackson 8/11/2016			TITLE: AM0 BLANK MODULE/ ADAPTER BRACKET	
			CHECKED BY: APPROVED BY:		SIZE: C	DRAWING NO.: 778228C	REV.: 1
					SCALE: 1/1	SHEET 1 OF 1	

1	21405	08/11/16	INITIAL RELEASE	JJRJ	MMA
REV.	ECN	DATE	DESCRIPTION	CHG BY	APPD BY