

6

5

4

3

2

1

CATALOG NUMBER	DESCRIPTION
OFCLV3	SINGLE FIBER CLEAVE TOOL

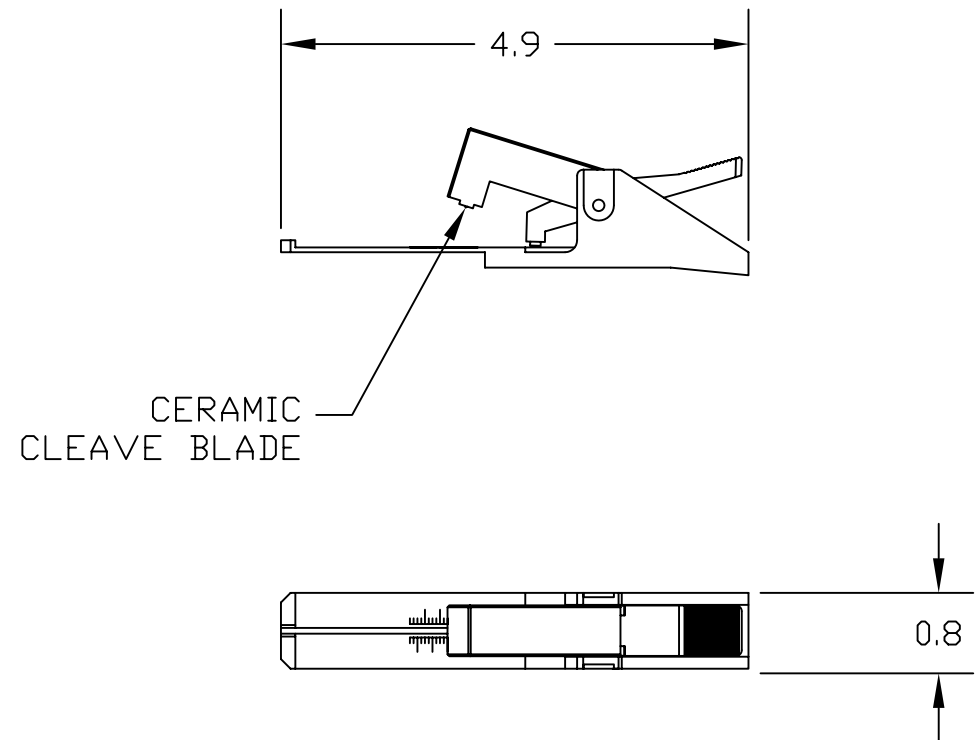

MARKINGS FOR VARIABLE LENGTHS

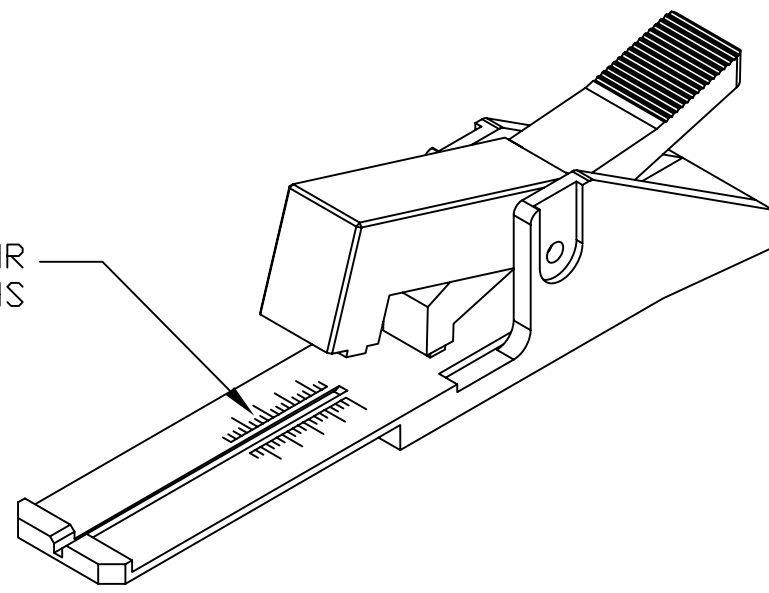

NOTES:

1. CLEAVE TOOL ALLOWS FOR VARIABLE CLEAVE LENGTHS FROM 5-20MM.
2. CLEAVE TOOL BLADE CAN EXECUTE THOUSANDS OF CLEAVES BEFORE BLADE REPLACEMENT IS NECESSARY.
3. SPECIFICATIONS SUBJECT TO CHANGE WITHOUT PRIOR NOTICE.

Created on AUTOCAD	DIMENSIONING AND TOLERANCE PER ANSI Y14.5M-1982 UNLESS OTHERWISE SPECIFIED, DIMENSIONS ARE IN INCHES (MM). TOLERANCES .XX = ±.01 (.25) .XXX = ±.005 (.127) .XXXX = ±.0025 (.0635) ANGLE TOL ±1°		PROJECT REFERENCE: 2005-031		 Hubbell Premise Wiring HUBBELL INCORPORATED (Delaware) 14 Lord's Hill Road, Stonington, Connecticut 06378
	IN ACCEPTING OUR DRAWINGS, BLUEPRINTS, OR SUPPORTING DOCUMENTATION FOR QUOTATION OR OTHER PURPOSES, YOU AGREE NOT TO DISCLOSE TO OTHERS THE IDEAS, INFORMATION, OR DESIGNS SHOWN HEREIN, AND THAT YOU WILL MAKE NO USE OF SAME WITHOUT PERMISSION		MATERIAL:		
			DRAWN BY: C. DUSSAULT 5/16/06		TITLE: VARIABLE LENGTH SINGLE FIBER CLEAVE TOOL
			CHECKED BY:		SIZE B DRAWING NO. HWS12408C REV. A SCALE: NONE SHEET 1 OF 1

A	5872	5/16/06	INITIAL RELEASE	CD	
REV.	ECN	DATE	DESCRIPTION	CHG BY	APPD BY