

ITEM NO.	DESCRIPTION	QTY.
1	FLAT HEAD SCREW	20
2	CONNECTOR	10
3	HEX NUT WITH TOOTH WASHER	20

CATALOG #	DESCRIPTION
XLR10	XLR SOLDER TERMINAL CONNECTOR

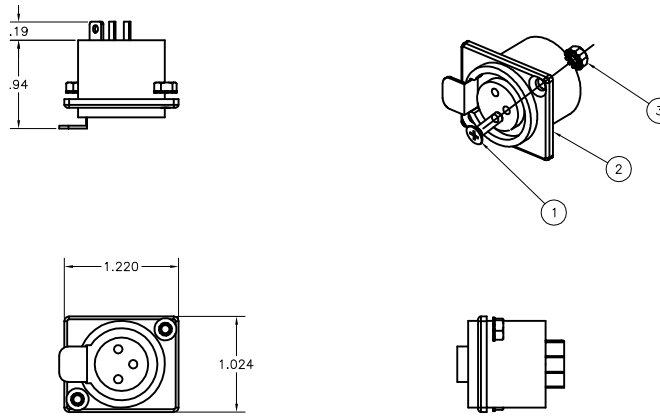

**PANEL CUT OUT**

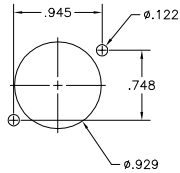

**NOTES:**

UNLESS OTHERWISE SPECIFIED:

- SPECIFICATIONS SUBJECT TO CHANGE WITHOUT NOTIFICATION.
- SOLD IN QTY OF 10 PER BAG.
- SUGGESTED PRECISION NUT DRIVER USED FOR INSTALLATION REF, WIHA 265 SERIES NUT DRIVER.

Created on AUTOCAD

DIMENSIONING AND TOLERANCE PER ANSI Y14.5M-1982 UNLESS OTHERWISE SPECIFIED, DIMENSIONS ARE IN INCHES (MM).

TOLERANCES  
 .XX = ±.01 (.25)  
 .XXX = ±.005 (.127)  
 .XXXX = ±.0025 (.0635)  
 ANGLE TOL ±1°

IN ACCEPTING OUR DRAWINGS, BLUEPRINTS, OR SUPPORTING DOCUMENTATION FOR QUOTATION OR OTHER PURPOSES, YOU AGREE NOT TO DISCLOSE TO OTHERS THE IDEAS, INFORMATION, OR DESIGNS SHOWN HEREIN, AND THAT YOU WILL MAKE NO USE OF SAME WITHOUT PERMISSION

PROJECT REFERENCE:  
2005-20

MATERIAL:

DRAWN BY:  
C. JOHNSTON 6/20/06

CHECKED BY:  
G. KIERSTEAD 7/5/06

APPROVED BY:  
G. KIERSTEAD 7/5/06



**Hubbell Premise Wiring**  
 HUBBELL INCORPORATED (Delaware)  
 14 Lord's Hill Road, Storington, Connecticut 06378

TITLE:  
XLR PANEL MOUNT  
SOLDER CONNECTOR

SIZE: C DRAWING NO.

**HWS12428C**

REV. A

SCALE: 1/1 SHEET 1 OF 1

REV.	ECN	DATE	DESCRIPTION	CHG BY	APPD BY
A	5869	6/20/06	INITIAL RELEASE	CRJ	