

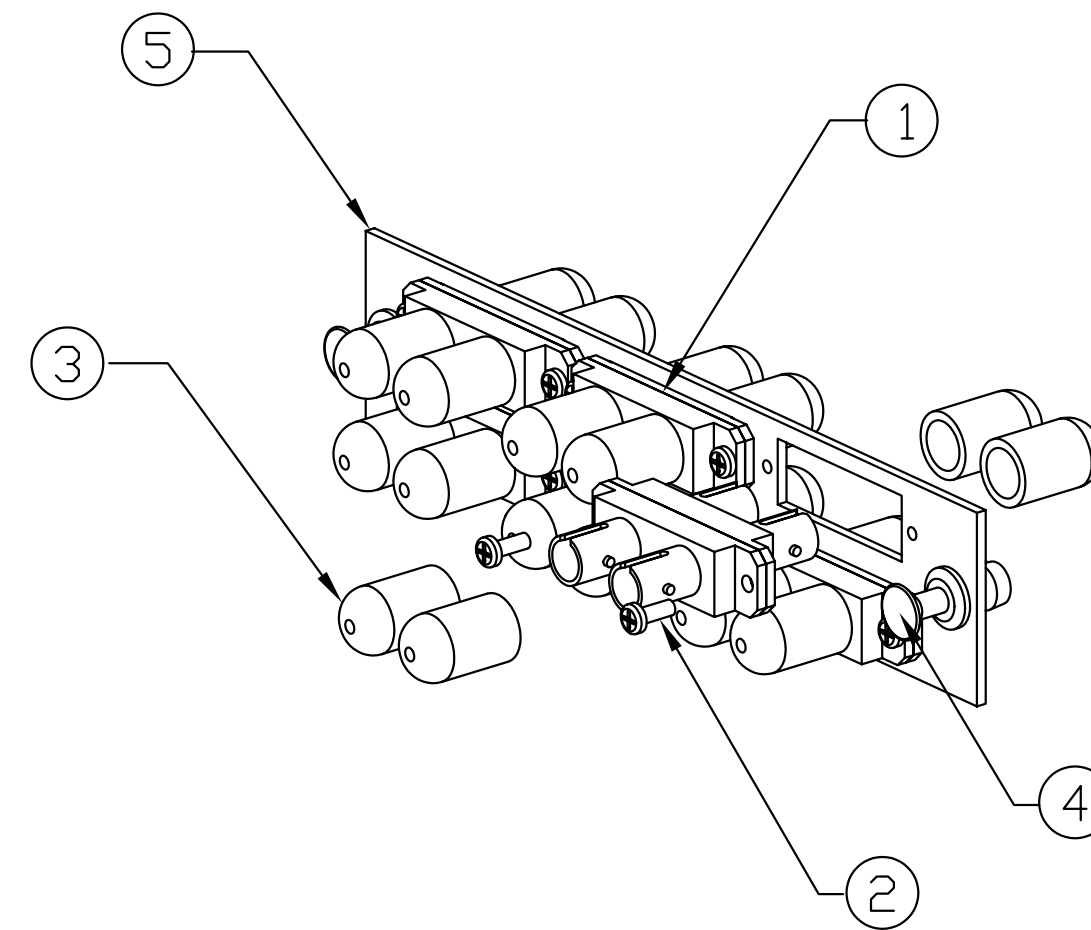

ITEM NO.	DESCRIPTION	QTY.	CATALOG NUMBER	DESCRIPTION	ADAPTER COLOR
1	ADAPTER, ST DUPLEX	6	FSPSTD6	12 PORT FSP PANEL WITH ST DUPLEX ADAPTERS	BLUE
2	SCREW, ADAPTER MOUNTING	12			
3	DUST CAP, ST	24			
4	NYLATCH PUSH FASTENER	2			
5	ADAPTER PANEL	1			

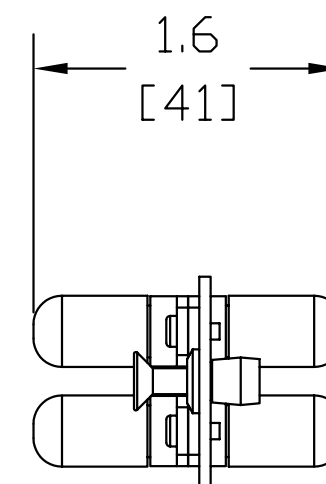
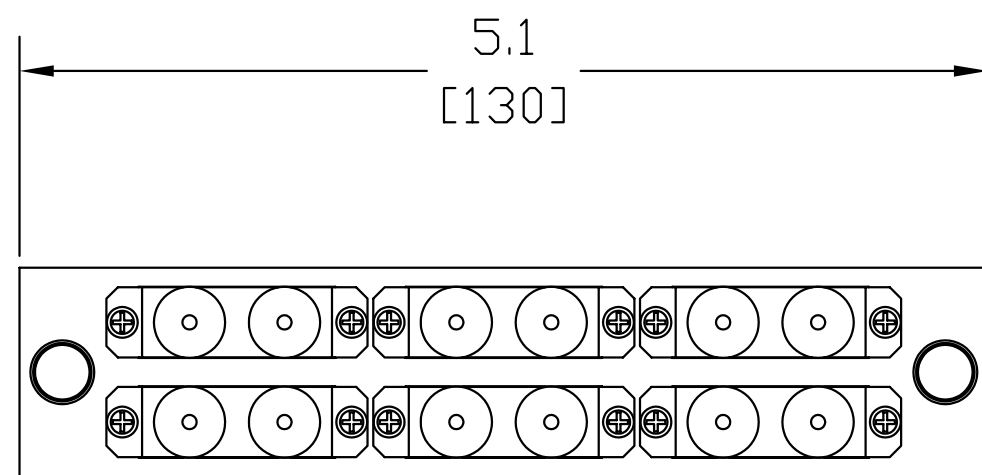
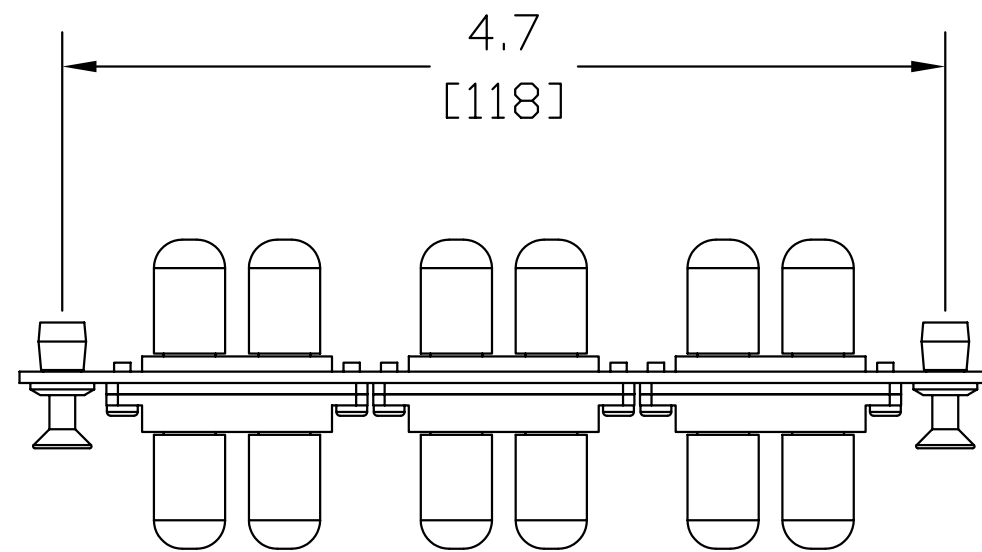

NOTES:

- SUPPLIED WITH PUSH/PULL FASTENERS FOR EASY INSTALLATION/REMOVAL.
- PANELS FIT INTO HUBBELL WALL MOUNT AND RACK MOUNT CABINETS.
- BLACK ELECTROSTATICALLY APPLIED POWDER COAT.
- ADAPTERS SUPPLIED WITH DUST CAPS INSTALLED
- HIGH QUALITY PHOSPHOR - BRONZE ALIGNMENT SLEEVES IN ALL ADAPTERS. SUITABLE FOR SINGLEMODE APPLICATIONS.
- SPECIFICATIONS SUBJECT TO CHANGE WITHOUT NOTICE.

Created on AUTOCAD	DIMENSIONING AND TOLERANCE PER ANSI Y14.5M-1982 UNLESS OTHERWISE SPECIFIED, DIMENSIONS ARE IN INCHES (MM). TOLERANCES .XX = ±.01 (.25) .XXX = ±.005 (.127) .XXXX = ±.0025 (.0635) ANGLE TOL ±1°		PROJECT REFERENCE: 07-001		 Hubbell Premise Wiring HUBBELL INCORPORATED (Delaware) 14 Lord's Hill Road, Stonington, Connecticut 06378		
	IN ACCEPTING OUR DRAWINGS, BLUEPRINTS, OR SUPPORTING DOCUMENTATION FOR QUOTATION OR OTHER PURPOSES, YOU AGREE NOT TO DISCLOSE TO OTHERS THE IDEAS, INFORMATION, OR DESIGNS SHOWN HEREIN, AND THAT YOU WILL MAKE NO USE OF SAME WITHOUT PERMISSION		MATERIAL: SEE NOTES			TITLE: ADAPTER ASSEMBLY FSP 12 PORT PANEL WITH ST DUPLEX ADAPTERS	
			DRAWN BY: C. DUSSAULT 2/16/07		SIZE: C	DRAWING NO.: HWS12512C	REV.:
			CHECKED BY:		SCALE: 1/1		SHEET 1 OF 1
		APPROVED BY:				A	

A	6054	2/16/07	INITIAL RELEASE	CD	
REV.	ECN	DATE	DESCRIPTION	CHG BY	APPD BY