

ITEM NO.	DESCRIPTION	QTY.
1	15-PIN D-SUB SCREW TERM CONNECTOR	1
2	3.5mm STEREO JACK SCREW TERMINAL	1
3	MOUNTING NUT	1
4	MOUNTING SCREWS	2
5	2U INFINESTATION MODULE	1
6	3-PIN XLR SCREW TERM CONNECTOR	1
7	15-PIN D-SUB INSTRUCTION SHEET	1
8	2U MODULE INSTALLATION INSTRUCTIONS	1

CATALOG NUMBER	COLOR	DESCRIPTION
IM153X20W	OFFICE WHITE	15-PIN, 3.5mm STEREO JACK, XLR INFINEMODULE

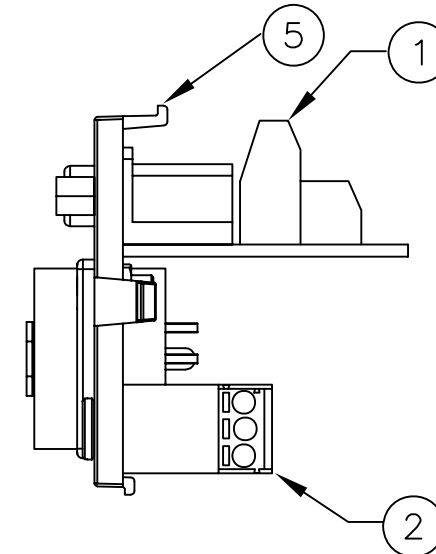
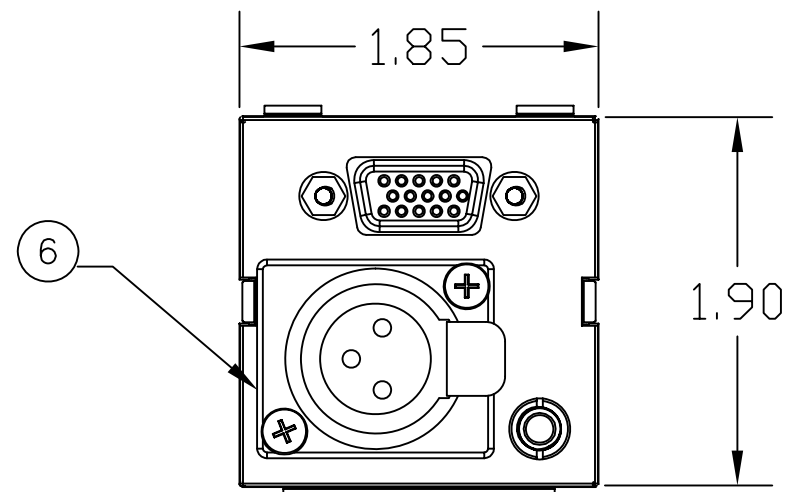
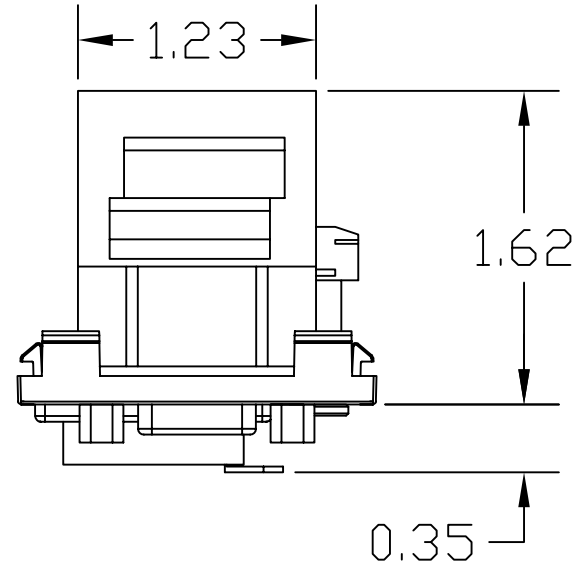

NOTES

UNLESS OTHERWISE SPECIFIED:

- SOLD IN CARTON INCREMENTS ONLY. CARTON CONTAINS 10 MODULES (INDIVIDUALLY BAGGED).
- SCREW TERMINAL TERMINATION.
- COLOR REFERS TO THE 1U MODULE ADAPTER NOT THE CONNECTOR COLORS.
- SPECIFICATIONS SUBJECT TO CHANGE WITHOUT NOTICE.

A	5998	4/23/07	INITIAL RELEASE	CG	
REV.	ECN	DATE	DESCRIPTION	CHG BY	APPD BY

Created on AUTOCAD	DIMENSIONING AND TOLERANCE PER ANSI Y14.5M-1982 UNLESS OTHERWISE SPECIFIED, DIMENSIONS ARE IN INCHES (MM). TOLERANCES .XX = ±.01 (.25) .XXX = ±.005 (.127) .XXXX = ±.0025 (.0635) ANGLE TOL ±1°	PROJECT REFERENCE: 2005-020
	IN ACCEPTING OUR DRAWINGS, BLUEPRINTS, OR SUPPORTING DOCUMENTATION FOR QUOTATION OR OTHER PURPOSES, YOU AGREE NOT TO DISCLOSE TO OTHERS THE IDEAS, INFORMATION, OR DESIGNS SHOWN HEREIN, AND THAT YOU WILL MAKE NO USE OF SAME WITHOUT PERMISSION	MATERIAL: ABS
		DRAWN BY: C. GRIBBLE 4/23/07
		CHECKED BY:
	APPROVED BY:	

		<b>Hubbell Premise Wiring</b> HUBBELL INCORPORATED (Delaware) 14 Lord's Hill Road, Stonington, Connecticut 06378	
		TITLE: INFINEMODULE, 2U SVGA, 3.5mm STEREO JACK, 3-PIN XLR SCREW TERM	
SIZE <b>B</b>	DRAWING NO. <b>HWS12537C</b>	REV. <b>A</b>	
SCALE: 1/1	SHEET 1 OF 1		