

ITEM NO.	DESCRIPTION	QTY.
1	ADAPTER, FC SIMPLEX	8
2	DUST CAP, FC (RED)	16
3	NYLATCH PUSH FASTENER	2
4	FSP PANEL 6 PORT ST SIMPLEX	1
5	NUT, HEX	8
6	WASHER, INTERNAL LOCK	8

CATALOG NUMBER	DESCRIPTION
FSPFCSS8	FSP PANEL 8 PORT WITH FC SIMPLEX ADAPTERS

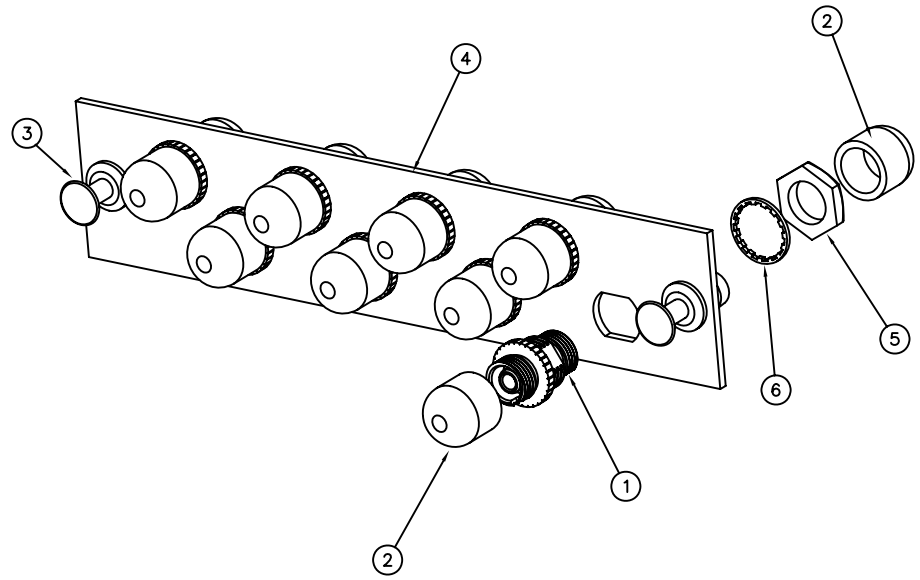
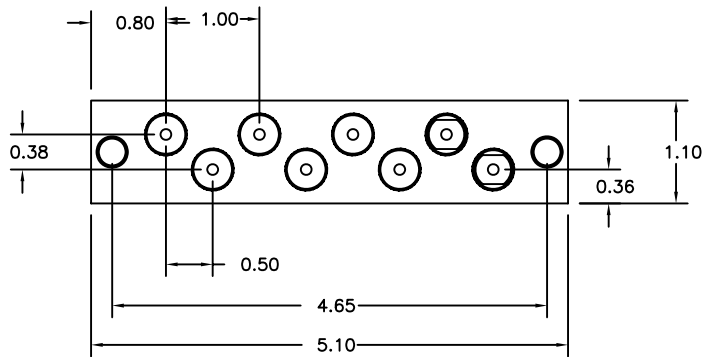
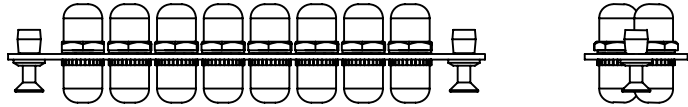

NOTES:

- SUPPLIED WITH PUSH/PULL FASTENERS FOR EASY INSTALLATION/REMOVAL.
- PANELS FIT INTO HUBBELL WALL MOUNT AND RACK MOUNT CABINETS.
- BLACK ELECTROSTATICALLY APPLIED POWDER COAT.
- ADAPTERS SUPPLIED WITH DUST CAPS INSTALLED
- HIGH QUALITY ZIRCONIA CERAMIC ALIGNMENT SLEEVES IN ALL ADAPTERS. SUITABLE FOR HIGH PRECISION APPLICATIONS.
- SPECIFICATIONS SUBJECT TO CHANGE WITHOUT NOTICE.

REV.	ECN	DATE	DESCRIPTION	CHG BY	APPD BY
A	6326	04/28/08	INITIAL RELEASE	NJR	

Created on AUTOCAD	DIMENSIONING AND TOLERANCE PER ANSI Y14.5M-1982 UNLESS OTHERWISE SPECIFIED, DIMENSIONS ARE IN INCHES (MM). TOLERANCES .XX = ±.01 (.25) .XXX = ±.005 (.127) .XXXX = ±.0025 (.0635) ANGLE TOL ±1°		PROJECT REFERENCE: MATERIAL: .0598" CRS WITH BLACK POWDER COAT FINISH		 Hubbell Premise Wiring HUBBELL INCORPORATED (Delaware) 14 Lord's Hill Road, Stonington, Connecticut 06378	
	IN ACCEPTING OUR DRAWINGS, BLUEPRINTS, OR SUPPORTING DOCUMENTATION FOR QUOTATION OR OTHER PURPOSES, YOU AGREE NOT TO DISCLOSE TO OTHERS THE IDEAS, INFORMATION, OR DESIGNS SHOWN HEREIN, AND THAT YOU WILL MAKE NO USE OF SAME WITHOUT PERMISSION		DRAWN BY: N.RICHARDS 05-15-08			TITLE: ASSY, 8 PORT FSP PANEL, WITH FC SIMPLEX ADAPTERS
			CHECKED BY: APPROVED BY:		SIZE: C DRAWING NO.: HWS12662C	REV.: A
					SCALE: 1/1 SHEET 1 OF 1	