

ITEM NO.	DESCRIPTION	QTY.
1	ADAPTER, FC-STYLE	1
2	DUST CAP	2
3	FLAT WASHER	1
4	INTERNAL LOCK WASHER	1
5	NUT	1

CATALOG NUMBER	DESCRIPTION	SPLIT SLEEVE MATERIAL
FANFCS6	ADAPTER, FC STYLE	ZIRCONIA

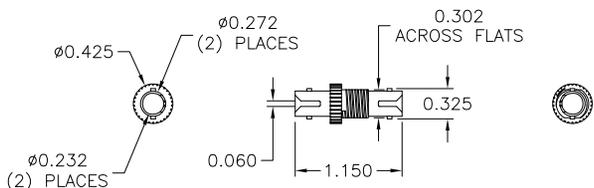

**ADAPTER**

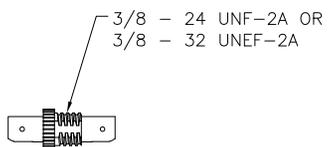
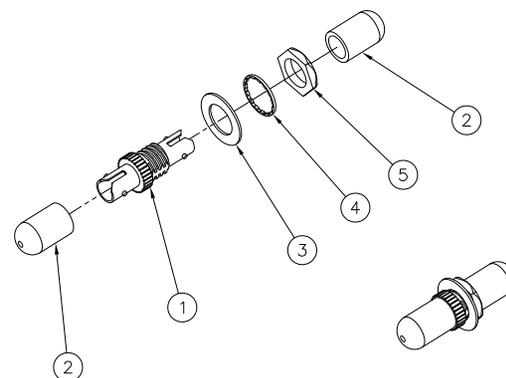
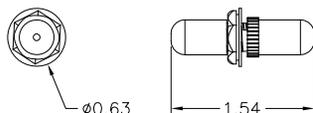
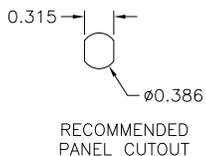
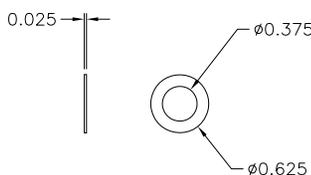

**WASHER**

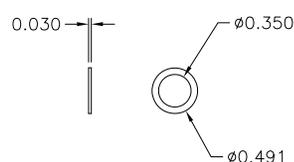

**LOCK WASHER**

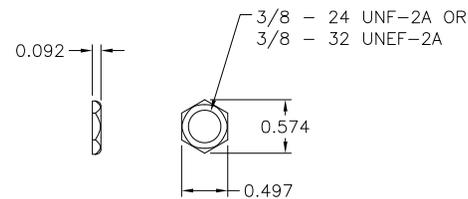

**NUT**

NOTES:

- ADAPTERS SUPPLIED WITH DUST CAPS INSTALLED AND HARDWARE BAGGED SEPARATELY.
- ADAPTER MATERIAL IS DIE CAST ZINC WITH BLACK OXIDE COATING.
- WASHERS ARE STAINLESS STEEL.
- NUT IS MACHINED BRASS, NICKEL PLATED.
- ZIRCONIA CERAMIC ALIGNMENT SLEEVE FOR PRECISION A APPLICATIONS.
- SPECIFICATIONS SUBJECT TO CHANGE WITHOUT NOTICE.

Created on AUTOCAD

DIMENSIONING AND TOLERANCE PER  
ANSI Y14.5M-1982  
UNLESS OTHERWISE SPECIFIED,  
DIMENSIONS ARE IN INCHES (MM).  
TOLERANCES  
.XX = ±.01 (.25)  
.XXX = ±.005 (.127)  
.XXXX = ±.0025 (.0635)  
ANGLE TOL ±1°

IN ACCEPTING OUR DRAWINGS,  
BLUEPRINTS, OR SUPPORTING  
DOCUMENTATION FOR QUOTATION  
OR OTHER PURPOSES, YOU AGREE  
NOT TO DISCLOSE TO OTHERS  
THE IDEAS, INFORMATION, OR  
DESIGNS SHOWN HEREIN, AND  
THAT YOU WILL MAKE NO USE  
OF SAME WITHOUT PERMISSION

PROJECT REFERENCE:  
NPD-03368

MATERIAL:

DRAWN BY:  
D.O'CONNOR 2/1/21

CHECKED BY:

APPROVED BY:



**Hubbell Premise Wiring**  
HUBBELL INCORPORATED (Delaware)  
23 Clara Drive, Mystic, Connecticut 06355

TITLE:  
FIBER OPTIC PRODUCTS  
ADAPTER, ST STYLE

SIZE  
C

DRAWING NO.  
HWS14993C

REV.  
1

SCALE: 1/1 SHEET 1 OF 1

REV.	ECN	DATE	DESCRIPTION	CHG BY	APPD BY
1	210202004508	2/1/21	INITIAL RELEASE	DPO	MMA