

CAT. #	SIZE	A	B	C	D	E	F	G
1042	1/2"	1.05 [26.7]	0.90 [22.9]	0.28 [7.2]	0.04 [1.0]	0.20 [0.5]	0.29 [7.4]	6
1043	3/4"	1.21 [30.7]	1.15 [29.2]	0.29 [7.3]	0.04 [1.0]	0.20 [0.5]	0.33 [8.4]	6
1044	1"	1.48 [37.6]	1.42 [35.9]	0.33 [8.4]	0.04 [1.0]	0.20 [0.5]	0.33 [8.4]	8
1045	1 1/4"	1.89 [48]	1.75 [44.3]	0.34 [8.6]	0.04 [1.0]	0.20 [0.5]	0.33 [8.4]	8
1046	1 1/2"	2.20 [55.9]	2.03 [51.6]	0.37 [9.5]	0.04 [1.0]	0.20 [0.5]	0.35 [8.9]	8
1048	2"	2.68 [68.1]	2.47 [62.7]	0.39 [9.8]	0.04 [1.0]	0.20 [0.5]	0.32 [8.1]	8

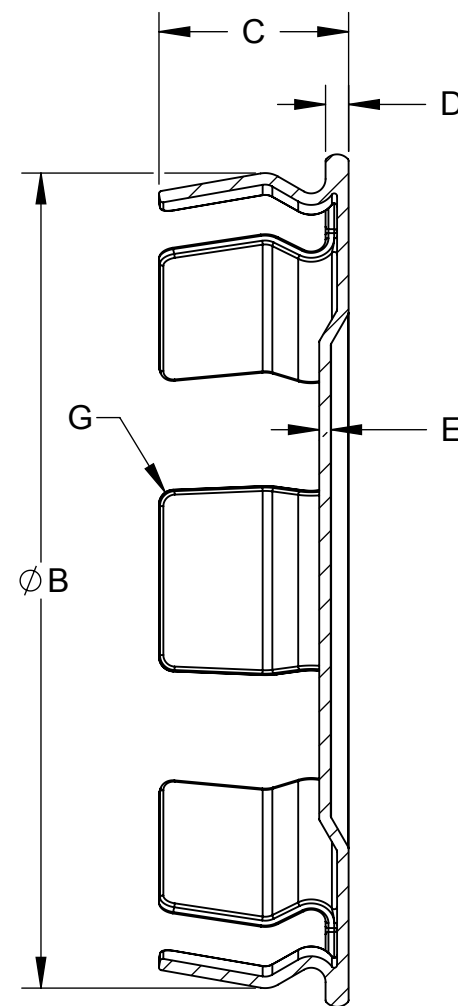
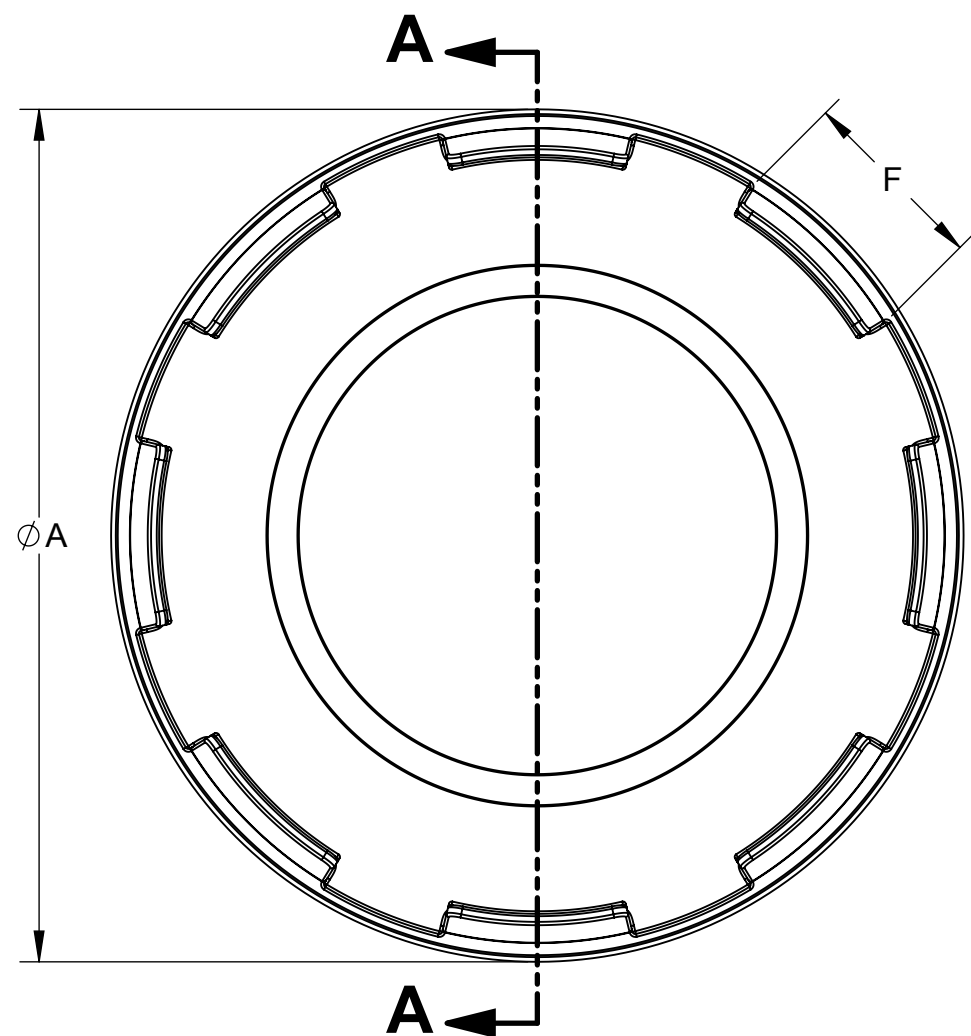

SECTION A-A

**NOTE:**

ALL DIMENSIONS ARE IN INCHES AND [MILLIMETERS].

**LIST OF PARTS**

DESCRIPTION	MATERIAL	FINISH
KNOCKOUT SEAL	MILD STEEL	ZINC

SYMBOL	REVISION DESCRIPTION	APP	DATE
	INITIAL RELEASE	S.J.	11/21/2016

THE DESIGN AND DIMENSIONS OF THE PRODUCT SHOWN ON THIS DRAWING ARE SUBJECT TO CHANGE WITHOUT NOTICE

TITLE: **KNOCKOUT SEAL**

<small>TOLERANCE UNLESS OTHERWISE SPECIFIED</small>  .XX DECIMAL ±.015 .XXX DECIMAL ±.005 ANGLE ±2°	<b>RACO</b> South Bend, Indiana		SCALE: <b>3:1</b>
	DRAWN BY:	M.M.	
	APP. BY:	S.J.	
	DATE:	11/21/2016	

FILE NO. : **KNOCKOUT SEAL CUS** DIMENSION SHEET FOR CAT. NO. **SEE CHART** SIZE: **B**