

REVISIONS			
REV.	DATE	DESCRIPTION	BY
-	06-01-23	INITIAL RELEASE	RMV

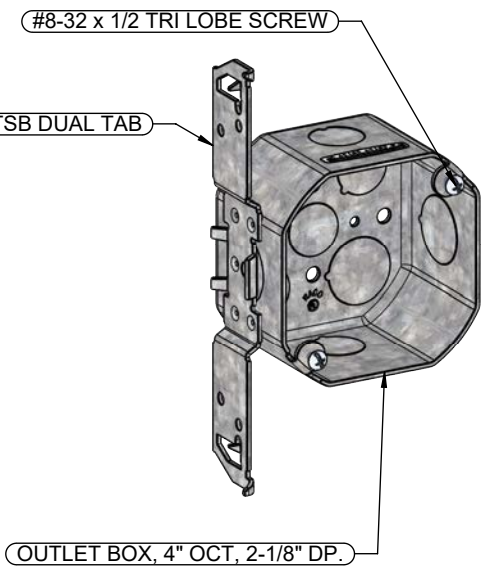
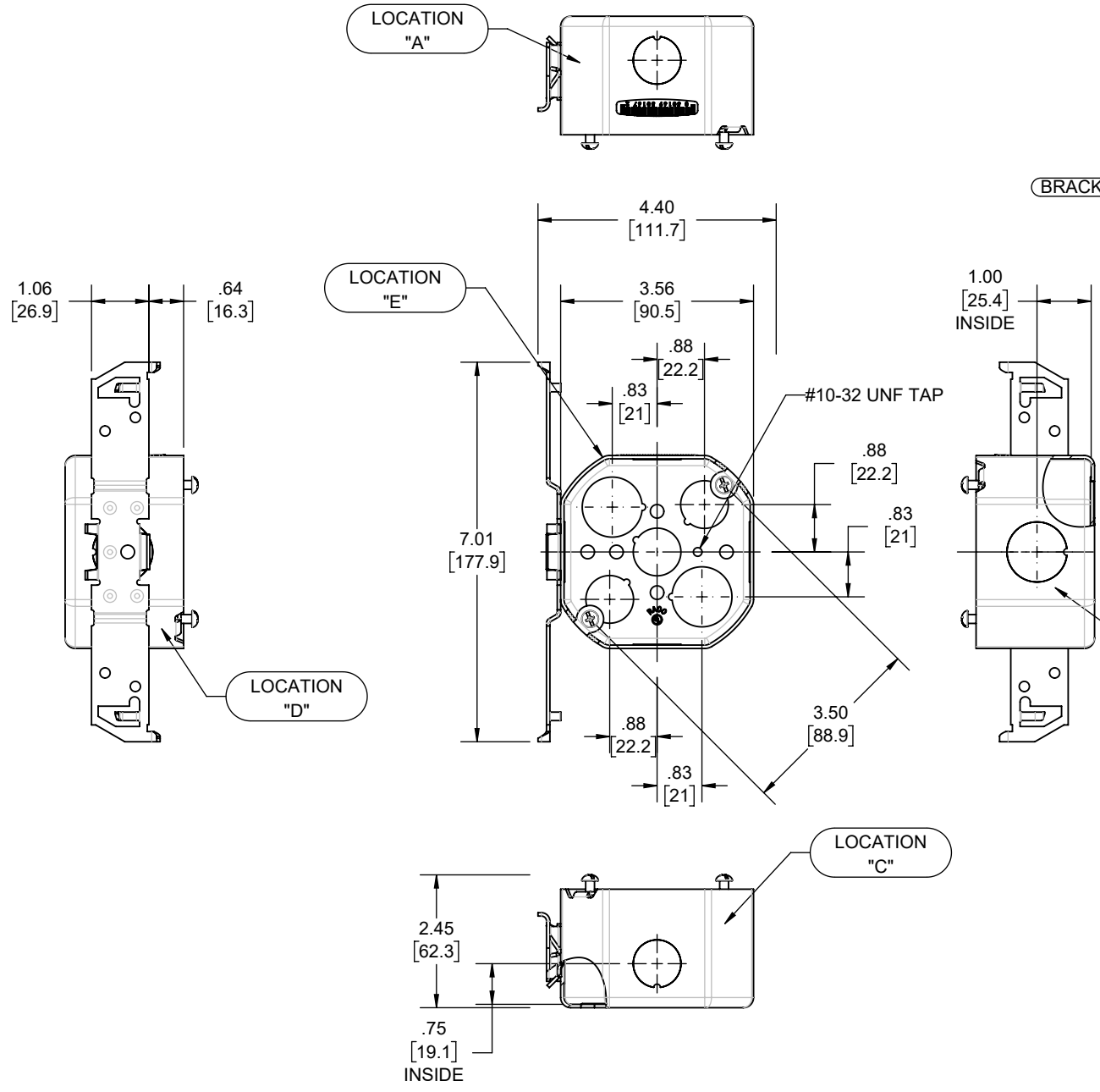

DESCRIPTION	MATERIAL	FINISH
FASTENERS	STEEL	GALVANIZED
BRACKET	STEEL	GALVANIZED
OUTLET BOX	STEEL	GALVANIZED

LIST OF PARTS

THE DESIGN AND DIMENSIONS OF THE PRODUCT SHOWN ON THIS DRAWING ARE SUBJECT TO CHANGE WITHOUT NOTICE

TITLE:
4" OCT BOX, 2-1/8 DP, TS BRACKET, 1/2"-3/4" KOs

KNOCKOUTS		
TRADE SIZE	LOCATION	QTY.
1/2" KO	E	3
3/4" KO	E	2
1/2" KO	A, C	1
3/4" KO	B	1

TOLERANCE UNLESS OTHERWISE SPECIFIED			SCALE: 1:3
.XX DECIMAL ± .015	.XXX DECIMAL ± .005		
ANGLE ± 2°		DRAWN BY: RMV	SCALE: 1:3
		APP. BY: N.S.	
		DATE: 06-01-23	

- NOTES:
- ALL DIMENSIONS ARE IN INCHES AND [MILLIMETERS]
 - VOLUME: 21.5 IN³ [352.3 CM³]
 - UL LISTED