

REVISIONS			
REV.	DATE	DESCRIPTION	BY
-	11-23-21	INITIAL RELEASE	RMV

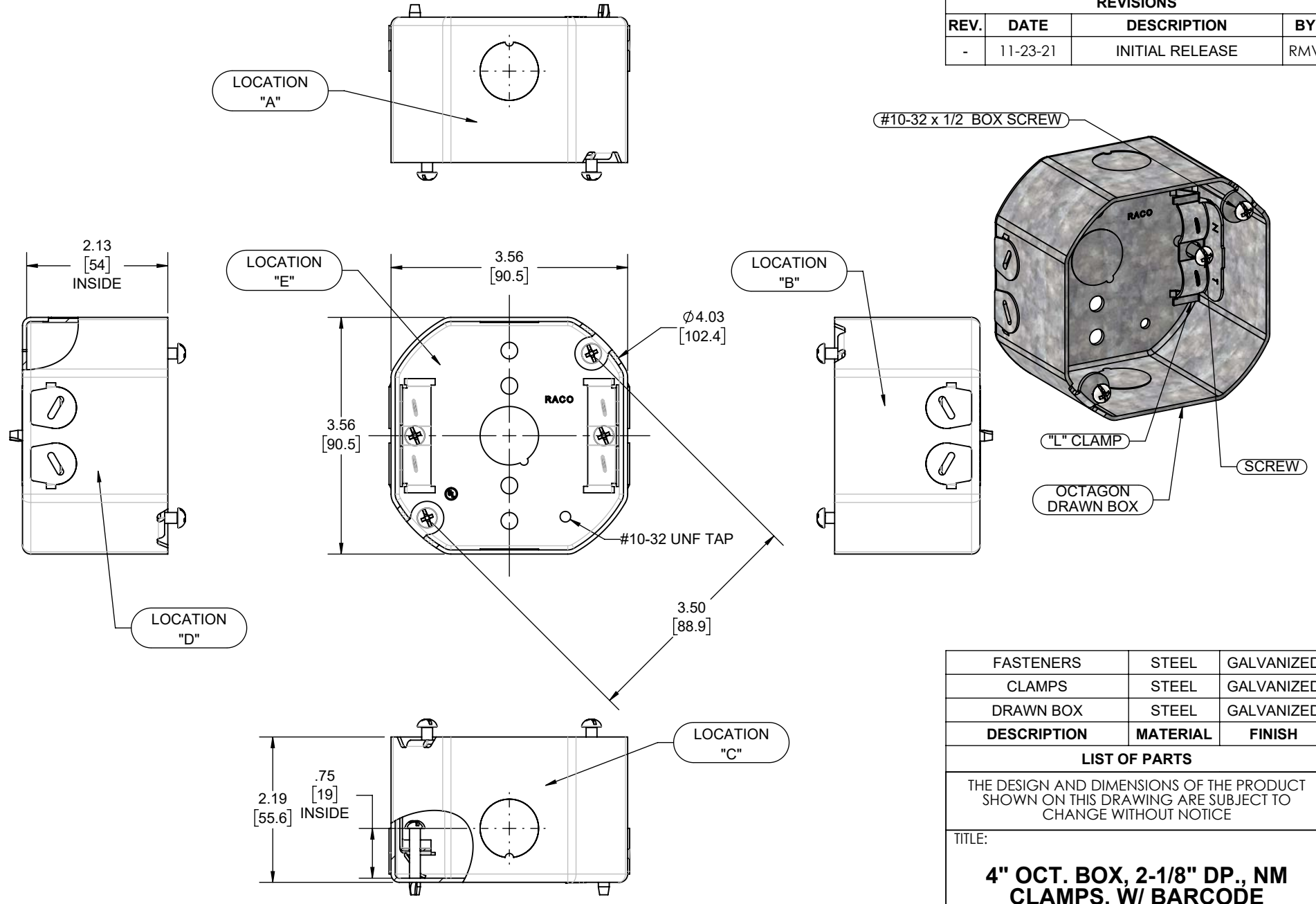

- NOTES:
1. ALL DIMENSIONS ARE IN INCHES AND [MILLIMETERS]
  2. BOX VOLUME: 21.5 IN<sup>3</sup> [352.3 CM<sup>3</sup>]
  3. UL LISTED

KNOCKOUTS		
TRADE SIZE	LOCATION	QTY.
1/2" KO	A, C, E	1
PRI-OUTS	B, D	2

FASTENERS	STEEL	GALVANIZED
CLAMPS	STEEL	GALVANIZED
DRAWN BOX	STEEL	GALVANIZED
DESCRIPTION	MATERIAL	FINISH

**LIST OF PARTS**

THE DESIGN AND DIMENSIONS OF THE PRODUCT SHOWN ON THIS DRAWING ARE SUBJECT TO CHANGE WITHOUT NOTICE

TITLE:  
**4" OCT. BOX, 2-1/8" DP., NM CLAMPS, W/ BARCODE**

TOLERANCE UNLESS OTHERWISE SPECIFIED  .XX DECIMAL ± .015 .XXX DECIMAL ± .005 ANGLE ± 2°			SCALE: 1:2 SIZE: <b>A</b>
	DRAWN BY:	RMV	
	APP. BY:	N.S.	
DATE:		11-23-21	