

ITEM NO.	Description	Material	Finish	QTY.
1	1½" TRADE SIZE RIGID COMPRESSION CONNECTOR BODY	C1008 COLD ROLLED STEEL	.0005 ZINC MIN.	1
2	2¼-14 UNS 2B COMPRESSION NUT	C1008 COLD ROLLED STEEL	.0005 ZINC MIN.	1
3	1½" TRADE SIZE GLAND RING	C1008 GALVANIZED STEEL	.0005 ZINC MIN.	1
4	1½-11½ NPT LOCK NUT	C1008 HOT ROLLED STEEL	.0005 ZINC MIN.	1

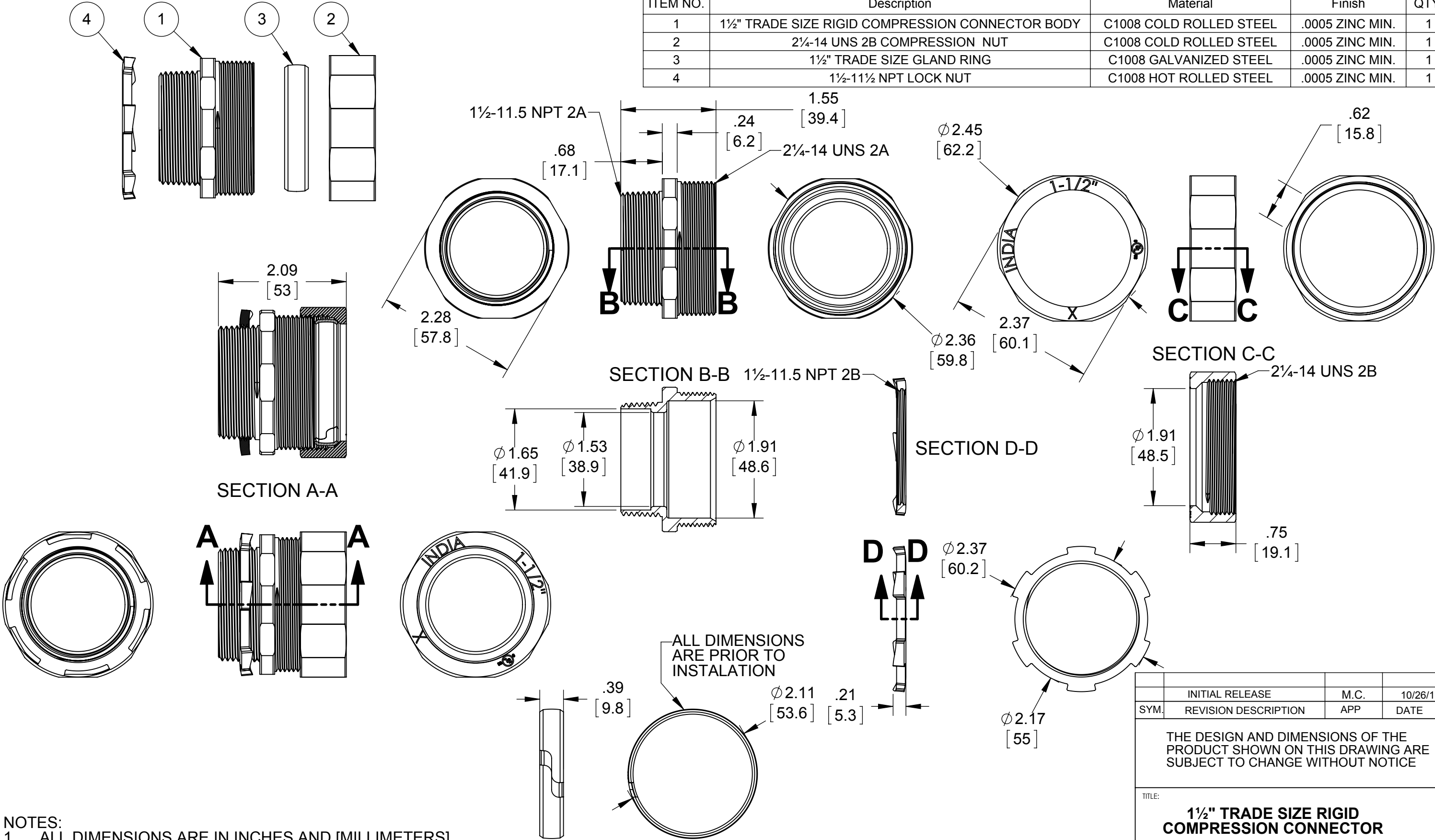

- NOTES:
1. ALL DIMENSIONS ARE IN INCHES AND [MILLIMETERS]
 2. LOCKNUT SHALL BE HAND-TIGHTENED AND THEN FURTHER TIGHTENED 1/4 TURN WITH A HAMMER AND A FLAT BLADED SCREWDRIVER OR BY AN EQUIVALENT METHOD
 3. COMPRESSION NUT IS TO BE TIGHTENED TO 1200 LBF-IN TORQUE
 4. CONCRETE TIGHT
 5. cULus® LISTED

ALL DIMENSIONS ARE PRIOR TO INSTALATION

INITIAL RELEASE	M.C.	10/26/15
SYM.	REVISION DESCRIPTION	APP DATE
THE DESIGN AND DIMENSIONS OF THE PRODUCT SHOWN ON THIS DRAWING ARE SUBJECT TO CHANGE WITHOUT NOTICE		
TITLE: 1½" TRADE SIZE RIGID COMPRESSION CONNECTOR		
TOLERANCE UNLESS OTHERWISE SPECIFIED		SIZE: B
.XX DECIMAL ±.015	DRAWN BY: J.RICHARD	SCALE: 2:3
.XXX DECIMAL ±.005		APP. BY: M.C.
ANGLE ±2°		DATE: 10/26/15