

ITEM NO.	Description	Material	Finish	QTY.
1	2" TRADE SIZE RIGID COMPRESSION CONNECTOR BODY	C1008 COLD ROLLED STEEL	.0005 ZINC MIN.	1
2	2.625-14 UNS 2B COMPRESSION NUT	C1008 COLD ROLLED STEEL	.0005 ZINC MIN.	1
3	2" TRADE SIZE GLAND RING	C1008 GALVANIZED STEEL	.0005 ZINC MIN.	1
4	2-11½ NPT 2B LOCK NUT	C1008 HOT ROLLED STEEL	.0005 ZINC MIN.	1

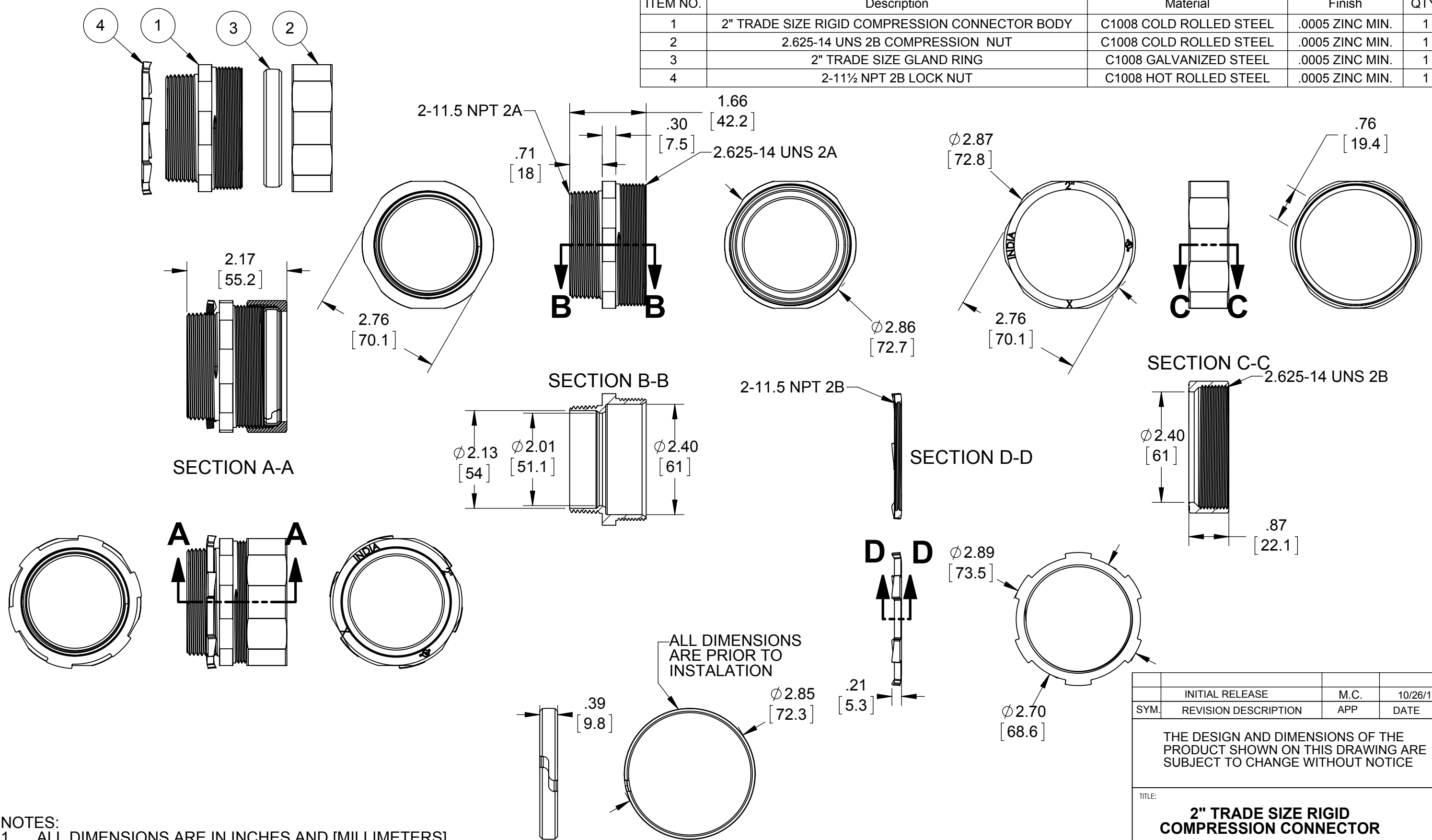

- NOTES:
1. ALL DIMENSIONS ARE IN INCHES AND [MILLIMETERS]
 2. LOCKNUT SHALL BE HAND-TIGHTENED AND THEN FURTHER TIGHTENED 1/4 TURN WITH A HAMMER AND A FLAT BLADED SCREWDRIVER OR BY AN EQUIVALENT METHOD
 3. COMPRESSION NUT IS TO BE TIGHTENED TO 1600 LBF-IN TORQUE
 4. CONCRETE TIGHT
 5. cULus® LISTED

INITIAL RELEASE	M.C.	10/26/15
SYM.	REVISION DESCRIPTION	APP DATE
THE DESIGN AND DIMENSIONS OF THE PRODUCT SHOWN ON THIS DRAWING ARE SUBJECT TO CHANGE WITHOUT NOTICE		
TITLE: 2" TRADE SIZE RIGID COMPRESSION CONNECTOR		
TOLERANCE UNLESS OTHERWISE SPECIFIED		SIZE: B
.XX DECIMAL ±.015	DRAWN BY: J.RICHARD	SCALE: 1:2
.XXX DECIMAL ±.005		APP. BY: M.C.
ANGLE ±2°		DATE: 10/26/15