

ITEM NO.	Description	Material	Finish	QTY.
1	3/4" TRADE SIZE RIGID COMPRESSION COUPLER BODY	C1008 COLD ROLLED STEEL	.0005 ZINC MIN.	1
2	3/4" TRADE SIZE GLAND RING	C1008 GALVANIZED STEEL	.0005 ZINC MIN.	2
3	1.25 - 18 UNEF 2B COMPRESSION NUT	C1008 COLD ROLLED STEEL	.0005 ZINC MIN.	2

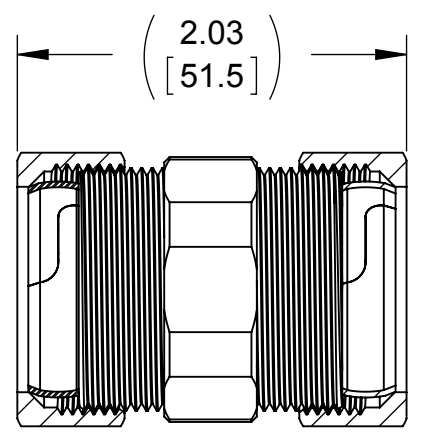

SECTION A-A

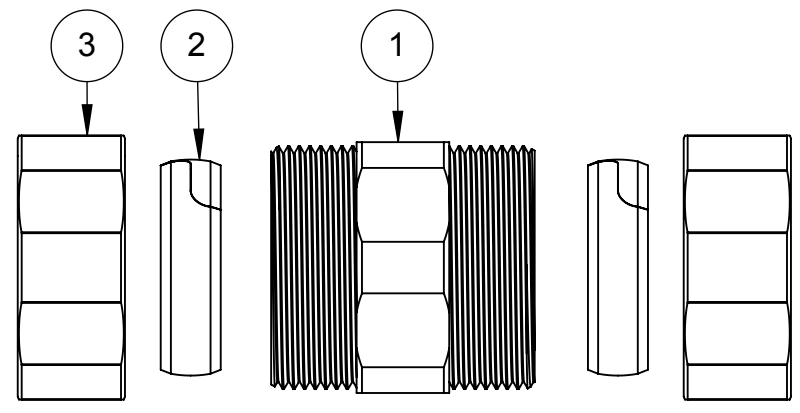
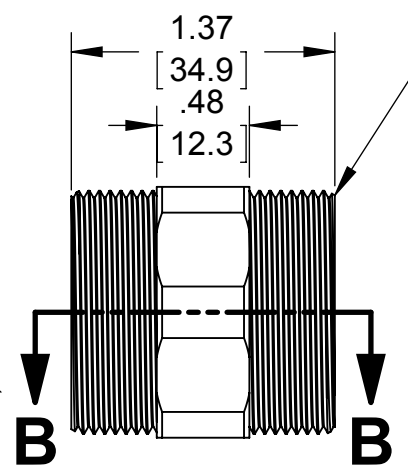
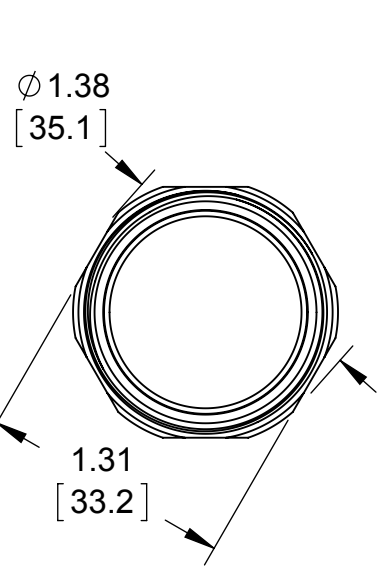
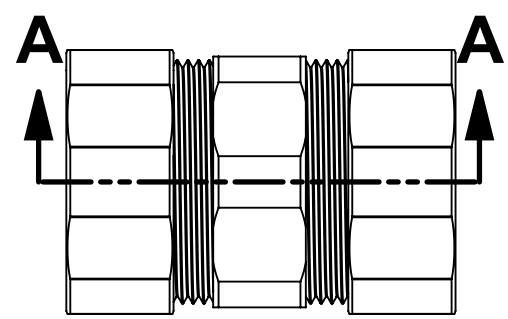

SECTION B-B

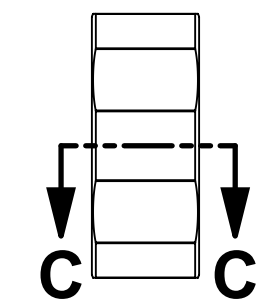
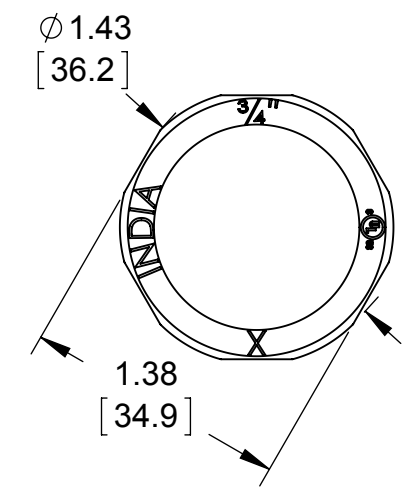
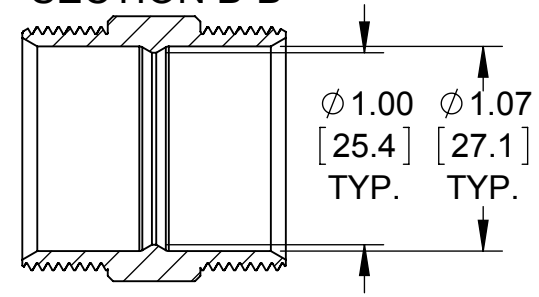

SECTION C-C

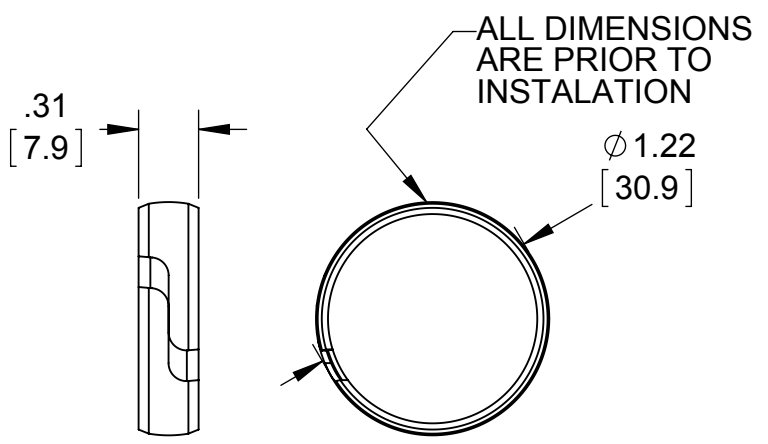
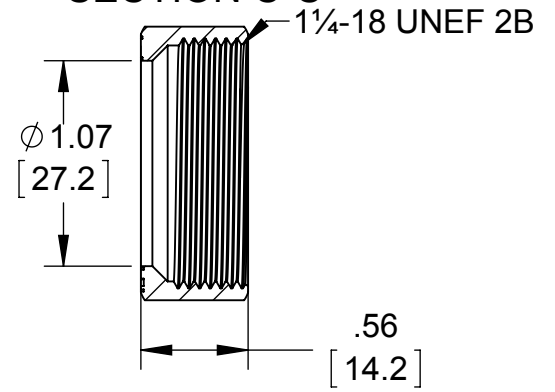

- NOTES:
1. ALL DIMENSIONS ARE IN INCHES AND [MILLIMETERS]
 2. COMPRESSION NUTS ARE TO BE TIGHTENED TO 500 LBF-IN TORQUE
 3. CONCRETE TIGHT
 4. cULus® LISTED

SYM.	REVISION DESCRIPTION	APP	DATE
	INITIAL RELEASE	M.C.	10/26/2015

THE DESIGN AND DIMENSIONS OF THE PRODUCT SHOWN ON THIS DRAWING ARE SUBJECT TO CHANGE WITHOUT NOTICE

TITLE:
3/4" TRADE SIZE RIGID COMPRESSION COUPLER

TOLERANCE UNLESS OTHERWISE SPECIFIED .XX DECIMAL ±.015 .XXX DECIMAL ±.005 ANGLE ±2°	RACO South Bend, Indiana		SCALE: 1:1
	DRAWN BY:	J.RICHARD	
	APP. BY:	M.C.	
	DATE:	10/26/2015	