

ITEM NO.	Description	Material	Finish	QTY.
1	1 1/4" TRADE SIZE RIGID COMPRESSION CONNECTOR BODY	C1008 COLD ROLLED STEEL	.0005 ZINC MIN.	1
2	1 1/4" TRADE SIZE GLAND RING	C1008 GALVANIZED STEEL	.0005 ZINC MIN.	2
3	2-14 UNS 2B COMPRESSION NUT	C1008 COLD ROLLED STEEL	.0005 ZINC MIN.	2

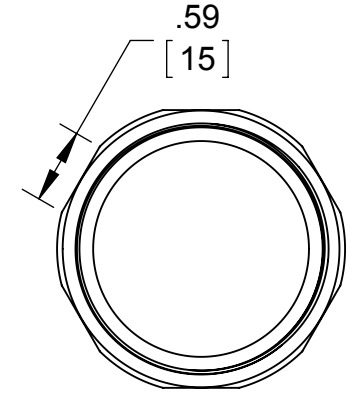
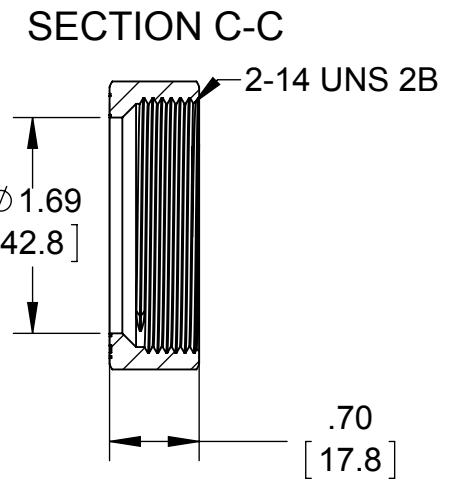
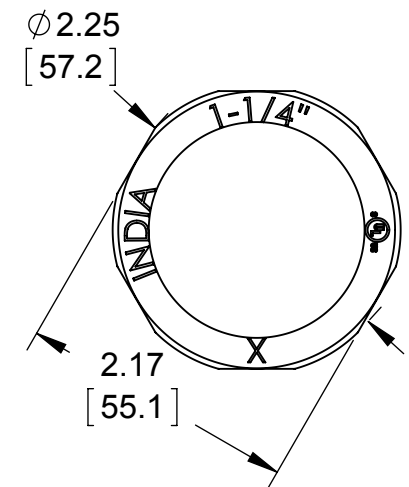
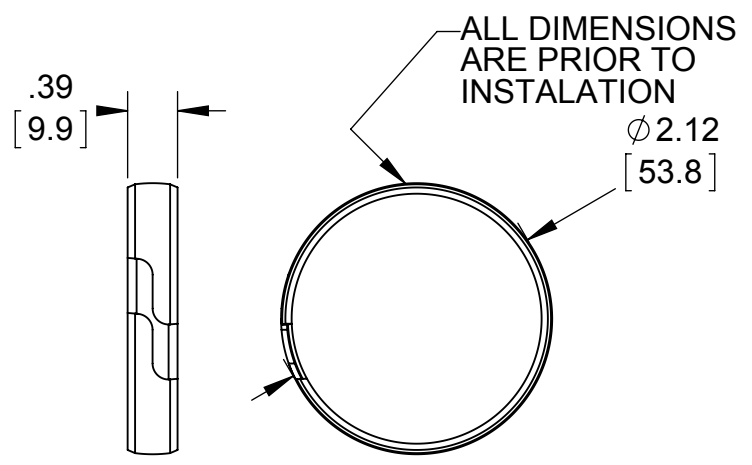
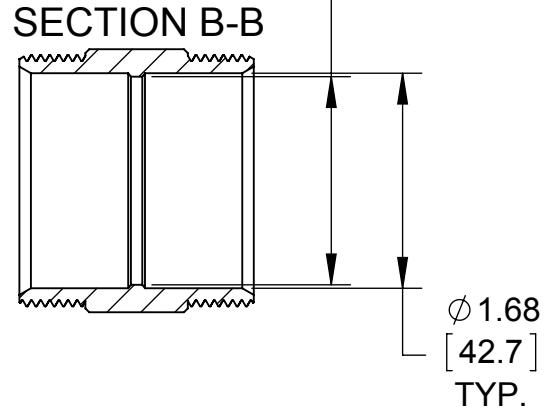
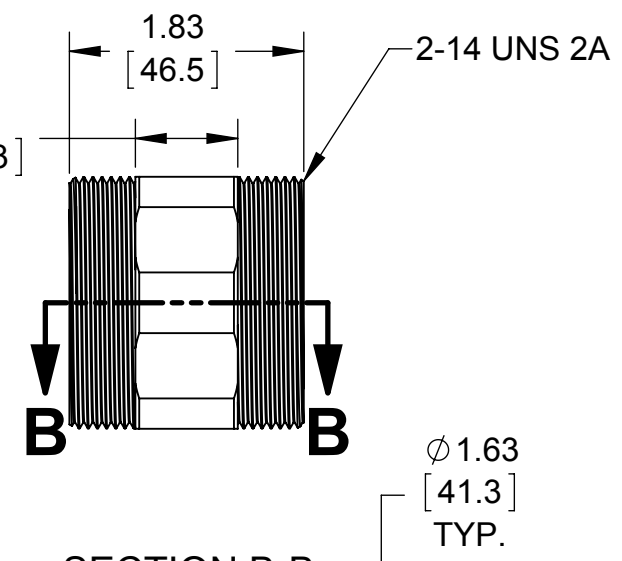
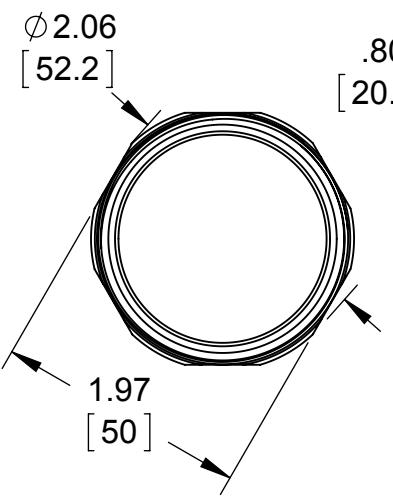
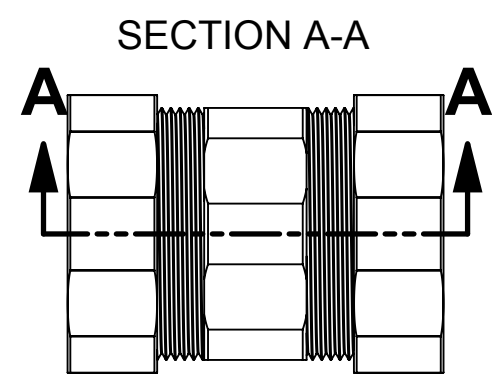
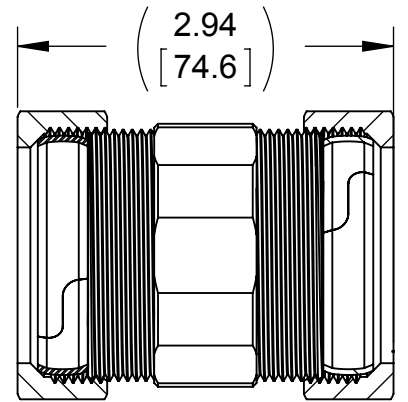
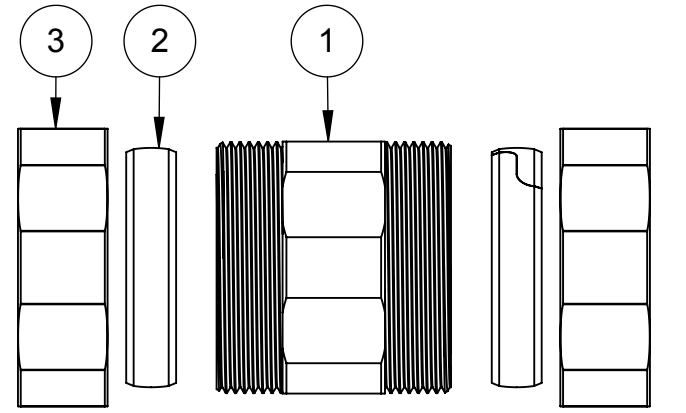

- NOTES:
- ALL DIMENSIONS ARE IN INCHES AND [MILLIMETERS]
 - COMPRESSION NUTS ARE TO BE TIGHTENED TO 1000 LBF-IN TORQUE
 - CONCRETE TIGHT
 - cULus® LISTED

	INITIAL RELEASE	M.C.	10/26/2015
SYM.	REVISION DESCRIPTION	APP	DATE

THE DESIGN AND DIMENSIONS OF THE PRODUCT SHOWN ON THIS DRAWING ARE SUBJECT TO CHANGE WITHOUT NOTICE

TITLE:
1 1/4" TRADE SIZE RIGID COMPRESSION COUPLER

TOLERANCE UNLESS OTHERWISE SPECIFIED .XX DECIMAL ±.015 .XXX DECIMAL ±.005 ANGLE ±2°	RACO South Bend, Indiana		SCALE: 2:3
	DRAWN BY:	J.RICHARD	
	APP. BY:	M.C.	
	DATE:	10/26/2015	