

LIST OF PARTS

DESCRIPTION	MATERIAL	FINISH
SPACER	STEEL	GALVANIZED
SIDE	STEEL	GALVANIZED
SCREW	STEEL	GALVANIZED
"B" BRACKET	STEEL	GALVANIZED

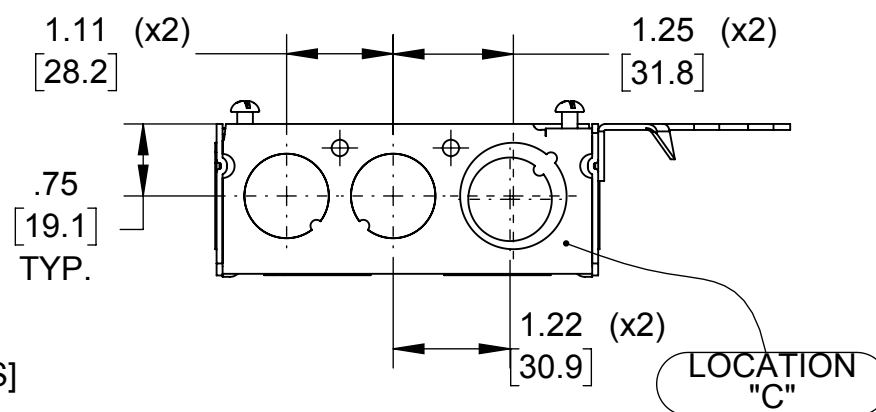
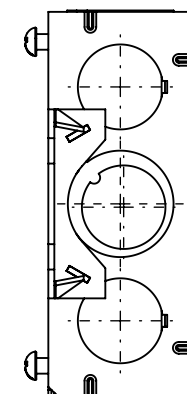
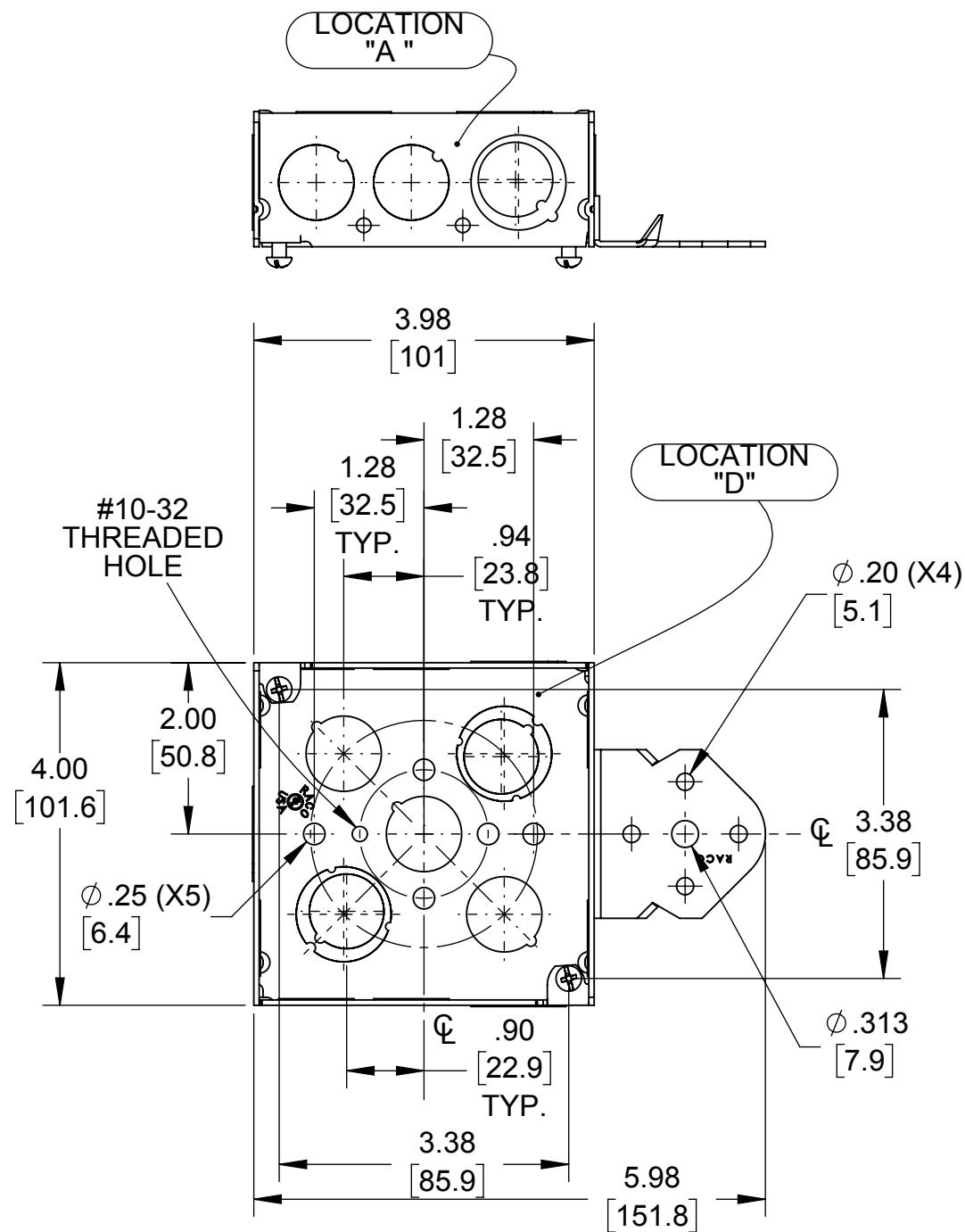
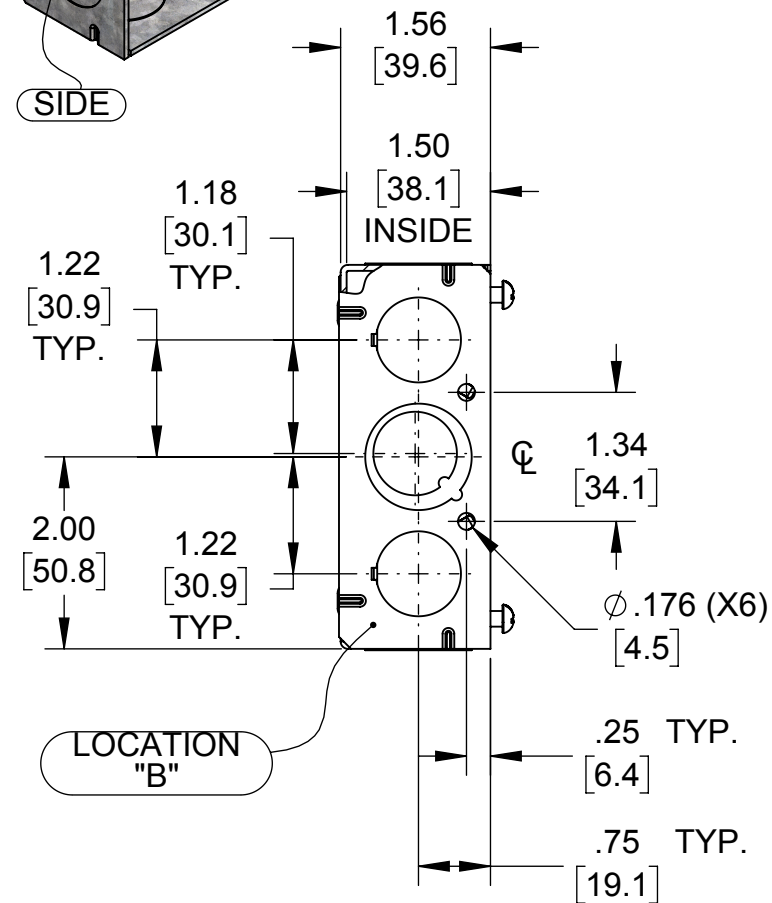
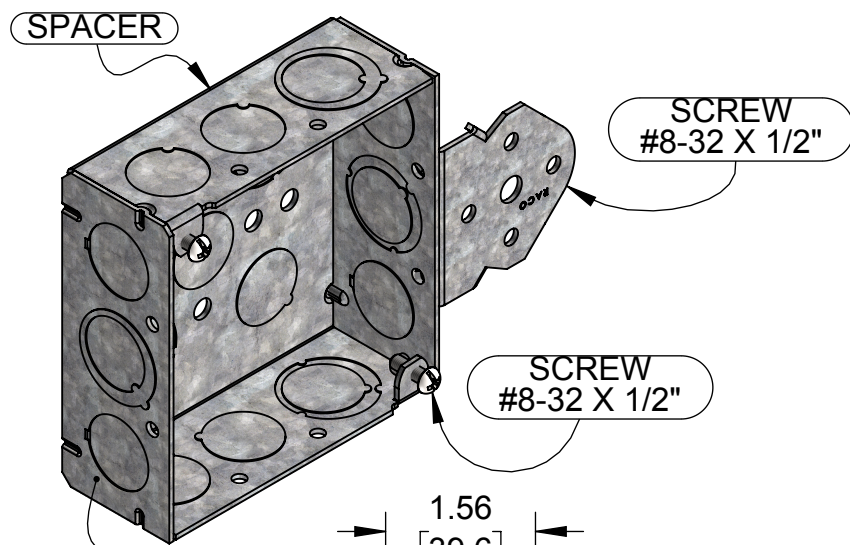

- NOTES:
 1. ALL DIMENSIONS ARE IN INCHES AND [MILLIMETERS]
 2. BOX VOLUME: 21.0 IN³ [344.1] CM³
 3. UL® LISTED

KNOCKOUTS		
TRADE SIZE	LOCATION	QTY.
(1/2"-3/4") TKO®	D	2
(1/2"-3/4") TKO®	A,B,C	1
1/2" KO	D	3
1/2" KO	A,B,C	2

SYMBOL	INITIAL RELEASE	N.S.	10-13-16
SYMBOL	REVISION DESCRIPTION	APP	DATE

THE DESIGN AND DIMENSIONS OF THE PRODUCT SHOWN ON THIS DRAWING ARE SUBJECT TO CHANGE WITHOUT NOTICE

TITLE:
4"SQ 1.5"DP BOX W/ "B"-BRKT & (9).5"KO & (5) .75" TKO'S

TOLERANCE UNLESS OTHERWISE SPECIFIED
 .XX DECIMAL ±.015
 .XXX DECIMAL ±.005
 ANGLE ±2°

RACO
 South Bend, Indiana

DRAWN BY: J.R.
 APP. BY: N.S.
 DATE: 10-13-16

SCALE: 1:2