

REVISIONS			
REV.	DATE	DESCRIPTION	BY
-	12-06-22	INITIAL RELEASE	RMV

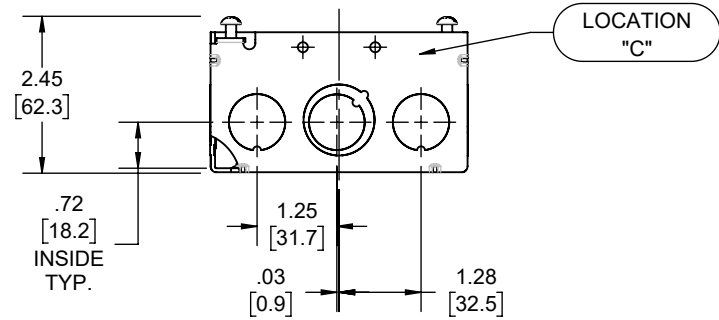
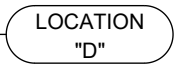
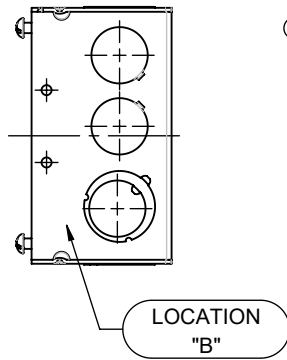
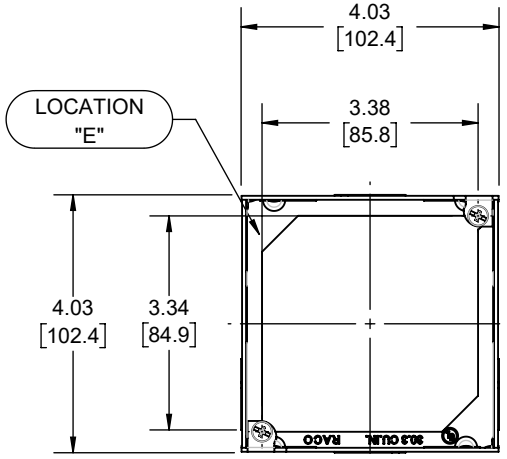
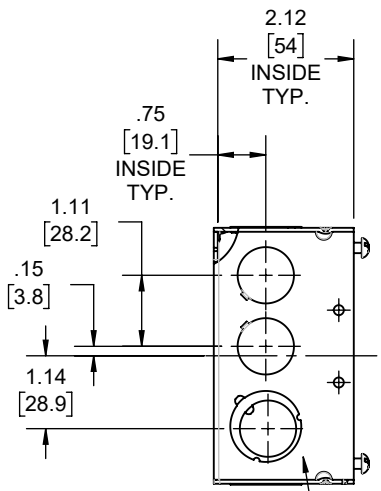
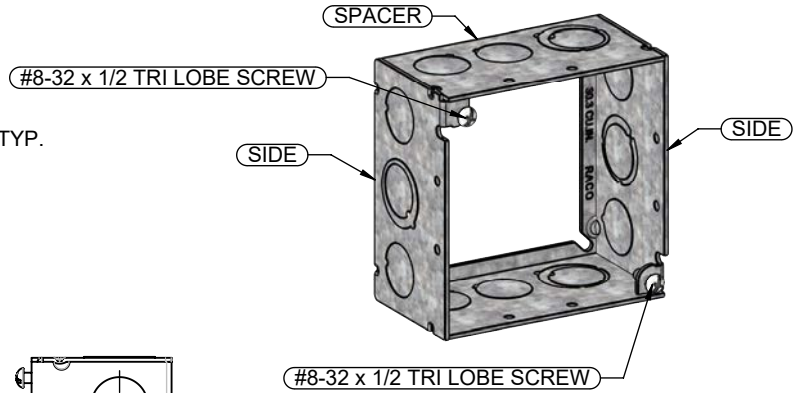
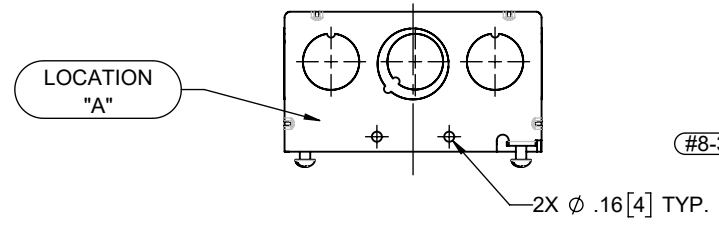

DESCRIPTION	MATERIAL	FINISH
FASTENERS	STEEL	GALVANIZED
SIDE	STEEL	GALVANIZED
SPACER	STEEL	GALVANIZED

LIST OF PARTS

THE DESIGN AND DIMENSIONS OF THE PRODUCT SHOWN ON THIS DRAWING ARE SUBJECT TO CHANGE WITHOUT NOTICE

TITLE:
**4" SQ. EXTENSION RING,
WELDED, 2-1/8" DP. W/ 1/2" KO'S
& 1/2"-3/4" TKO'S**

KNOCKOUTS		
TRADE SIZE	LOCATION	QTY.
(1/2"-3/4") TKO*	A, B, C, D	1
1/2" KO	A, B, C, D	2

TOLERANCE UNLESS OTHERWISE SPECIFIED			SCALE: 1:3
.XX DECIMAL ± .015	.XXX DECIMAL ± .005		
ANGLE ± 2°		DRAWN BY: RMV	DATE: 12-06-22
		APP. BY: N.S.	

- NOTES:
- ALL DIMENSIONS ARE IN INCHES AND [MILLIMETERS]
 - VOLUME: 30.3 IN³ [496.5CM³]
 - UL LISTED