

CAT. #	SIZE	A	B	C	D	E	F	G	H	J	K
2122	1/2"	1.50 [38.1]	1.02 [25.8]	1.13 [28.6]	0.73 [18.4]	0.85 [21.3]	0.64 [16.3]	0.82 [20.7]	0.60 [15.1]	0.31 [7.9]	0.858-14UNS
2123	3/4"	1.57 [39.9]	1.24 [31.5]	1.38 [35.1]	0.95 [24.0]	1.07 [27.1]	0.79 [20.1]	1.02 [25.8]	0.76 [19.3]	0.33 [8.4]	1.087-14UNS
2124	1"	1.70 [43.1]	1.47 [37.3]	1.71 [43.3]	1.17 [29.7]	1.34 [34.0]	1.04 [26.4]	1.27 [32.3]	1.00 [25.4]	0.33 [8.4]	1.331-18UNS

REVISIONS			
REV.	DATE	DESCRIPTION	BY:
-	07-26-21	INITIAL RELEASE OF DRAWING	VS

FILE NO. :
SET SCREW CONNECTOR-STEEL INSULATED 0.50 TO 1.00 CUS

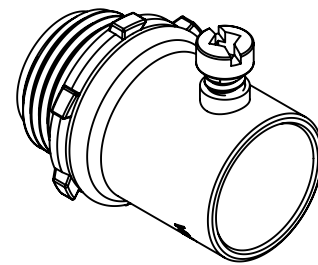

ISOMETRIC VIEW

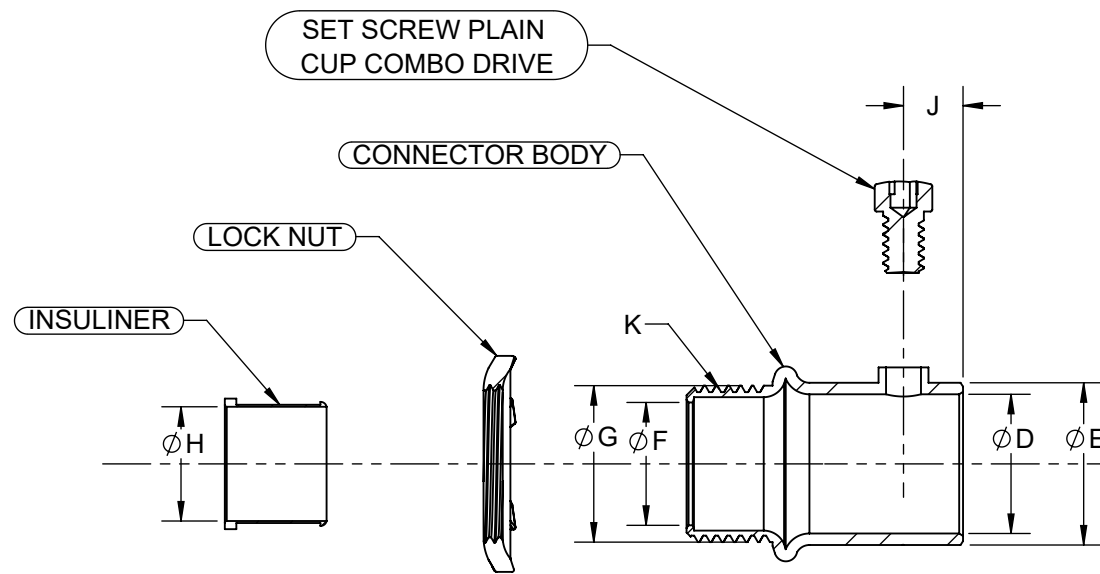
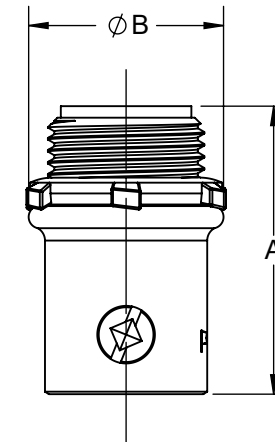

SECTION A-A

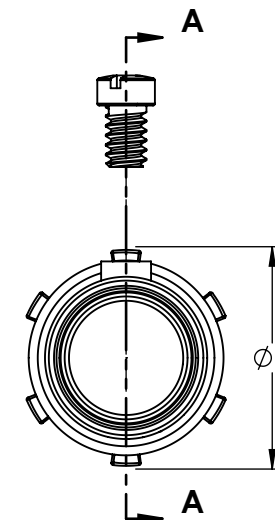

DESCRIPTION	MATERIAL	FINISH
INSULINER	NYLON	-
LOCK NUT	STEEL	ZINC
SET SCREW PLAIN CUP COMBO DRIVE	STEEL	ZINC
CONNECTOR BODY	STEEL	ZINC

LIST OF PARTS

THE DESIGN AND DIMENSIONS OF THE PRODUCT SHOWN ON THIS DRAWING ARE SUBJECT TO CHANGE WITHOUT NOTICE

TITLE:
SET SCREW CONNECTOR-STEEL INSULATED 0.50 TO 1.00 CUS

TOLERANCE UNLESS OTHERWISE SPECIFIED
.XX DECIMAL ±.015
.XXX DECIMAL ±.005
ANGLE ±2°



DRAWN BY:	VS	SCALE:	SIZE:
APP. BY:	N.S.	1:1	B
DATE:	07-26-21		

NOTES:

- ALL DIMENSIONS ARE IN INCHES AND [MILLIMETERS].
- LOCKNUT SHALL BE HAND-TIGHTENED AND THEN FURTHER TIGHTENED 1/4 TURN WITH A HAMMER AND A FLAT BLADED SCREWDRIVER OR BY AN EQUIVALENT METHOD.
- cULus LISTED.

DIMENSION SHEET FOR CAT. NO.
SEE CHART

1 1/4" x 1 1/4"