

REVISIONS			
REV.	DATE	DESCRIPTION	BY
-	12-12-22	INITIAL RELEASE	RMV

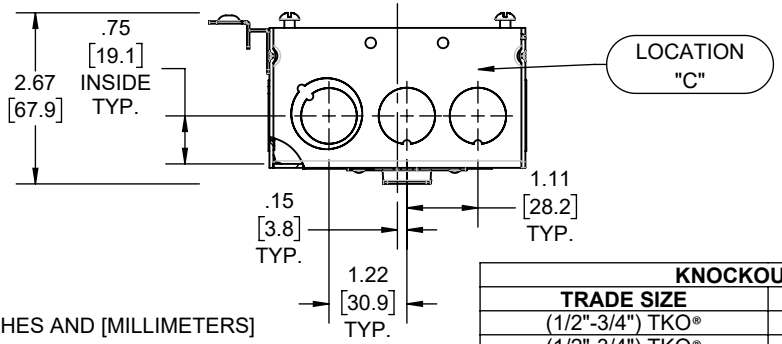
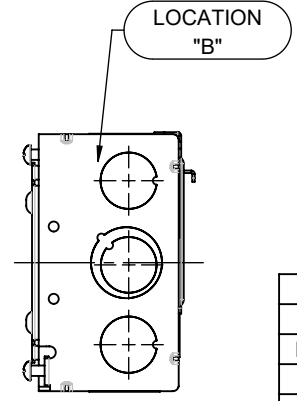
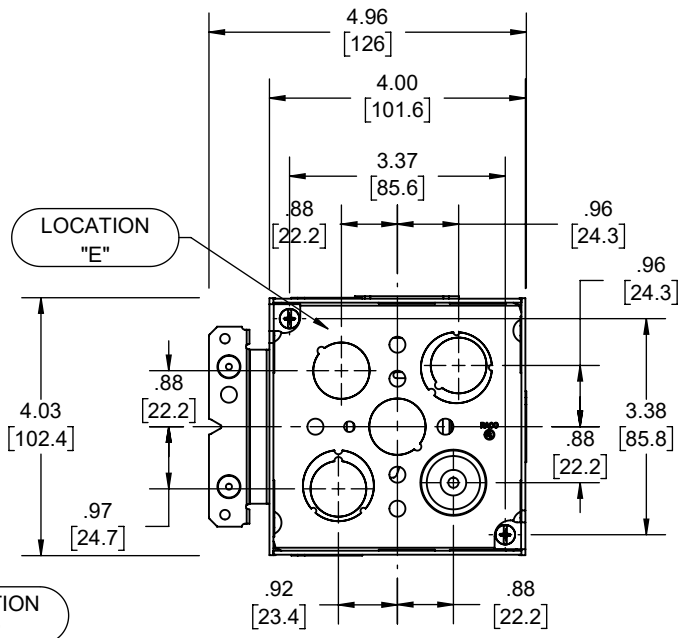
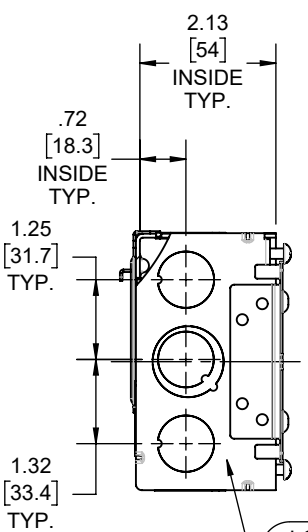
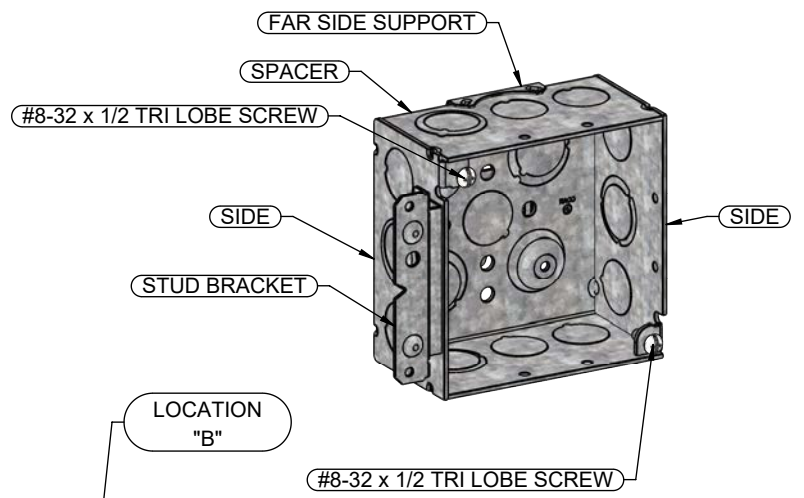
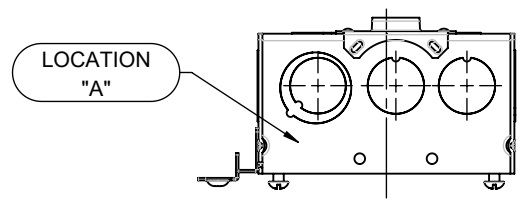

KNOCKOUTS		
TRADE SIZE	LOCATION	QTY.
(1/2"-3/4") TKO*	A, B, C, D	1
(1/2"-3/4") TKO*	E	2
1/2" KO	A, B, C, D, E	2

DESCRIPTION	MATERIAL	FINISH
FAR SIDE SUPPORT	STEEL	GALVANIZED
STUD BRACKET	STEEL	GALVANIZED
FASTENERS	STEEL	GALVANIZED
SIDE	STEEL	GALVANIZED
SPACER	STEEL	GALVANIZED

LIST OF PARTS

THE DESIGN AND DIMENSIONS OF THE PRODUCT SHOWN ON THIS DRAWING ARE SUBJECT TO CHANGE WITHOUT NOTICE

TITLE:
ASSEMBLY 4" SQ x 2-1/8" DEEP BOX WITH FAR SIDE SUPPORT AND (1) STUD BRACKET

- NOTES:
1. ALL DIMENSIONS ARE IN INCHES AND [MILLIMETERS]
 2. VOLUME: 30.3 IN³ [496.5 CM³]
 3. UL LISTED

TOLERANCE UNLESS OTHERWISE SPECIFIED
 .XX DECIMAL ± .015
 .XXX DECIMAL ± .005
 ANGLE ± 2°



DRAWN BY:	RMV	SCALE:	SIZE:
APP. BY:	N.S.		
DATE:	12-12-22	1:3	A