

REVISIONS			
REV.	DATE	DESCRIPTION	BY
-	03-10-17	INITIAL RELEASE OF DRAWING	RMV
1	11-01-19	UPDATED WITH GROUND BUMP	RMV

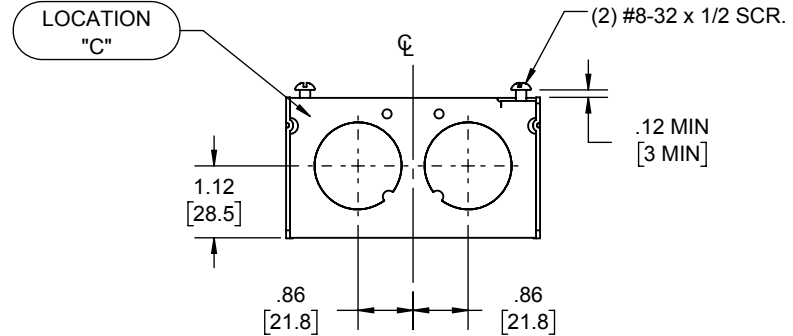
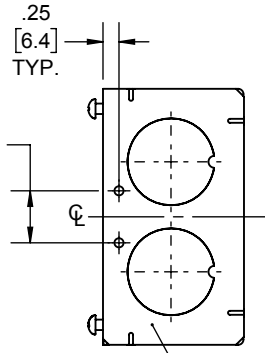
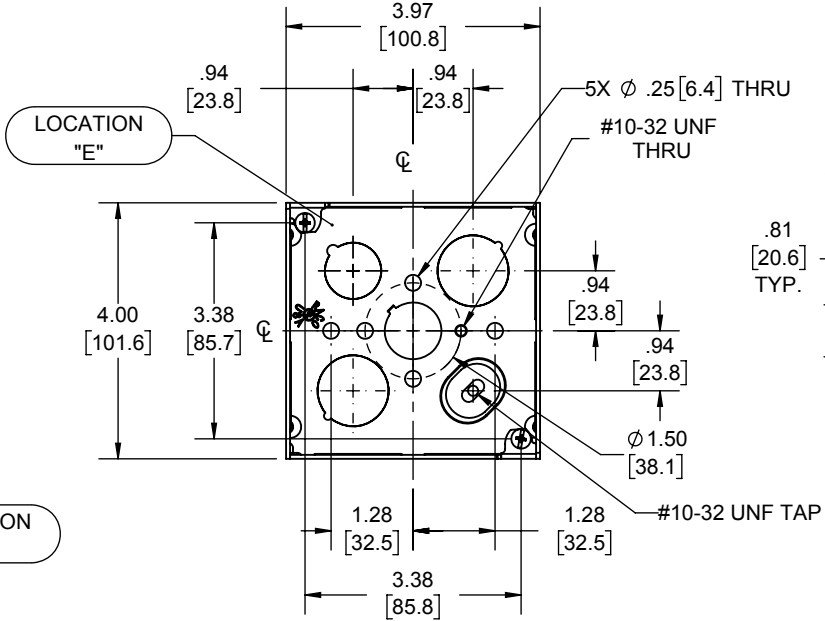
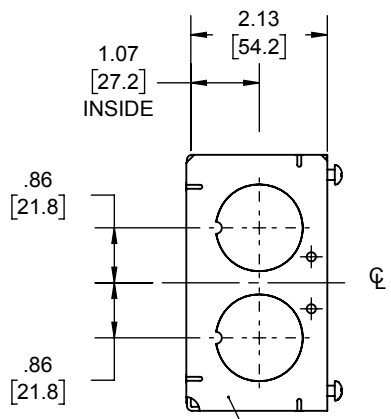
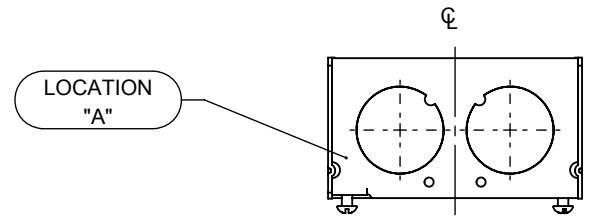
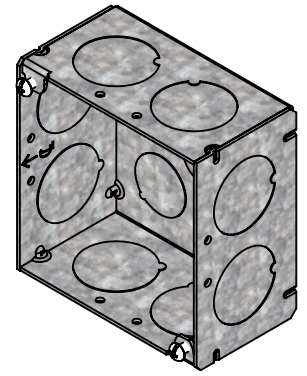

DESCRIPTION	MATERIAL	FINISH
FASTENERS	STEEL	GALVANIZED
SIDE	STEEL	GALVANIZED
SPACER	STEEL	GALVANIZED

LIST OF PARTS

THE DESIGN AND DIMENSIONS OF THE PRODUCT SHOWN ON THIS DRAWING ARE SUBJECT TO CHANGE WITHOUT NOTICE

TITLE:
4" SQUARE 2-1/8" DP BOX

KNOCKOUTS		
TRADE SIZE	LOCATION	QTY.
1/2" KO	E	2
3/4" KO	E	2
1" KO	A, B, C, D	2

TOLERANCE UNLESS OTHERWISE SPECIFIED

.XX DECIMAL ± .015
.XXX DECIMAL ± .005
ANGLE ± 2°



DRAWN BY:	RMV	SCALE:	1:3
APP. BY:	N.S.		
DATE:	03-10-17		

- NOTES:
- ALL DIMENSIONS ARE IN INCHES AND [MILLIMETERS]
 - BOX VOLUME: 30.3 IN³ [496.5 CM³]
 - UL LISTED