

CAT.#	SIZE	A	B	C	D	E	F
2402	1/2"	2.53 [64.3]	2.50 [63.5]	1.68 [42.7]	2.87 [72.9]	#10-24 X 1" PAN HEAD SCREW	#10-24 X 1/2" ROUND HEAD SCREW
2403	3/4"	2.78 [70.6]	2.74 [69.6]	1.91 [48.5]	3.20 [81.3]	#10-24 X 1" PAN HEAD SCREW	#10-24 X 1/2" ROUND HEAD SCREW
2404 (2404-x)	1"	3.14 [79.8]	2.98 [75.7]	2.15 [54.6]	3.36 [85.3]	#10-24 X 1" PAN HEAD SCREW	#10-24 X 1/2" ROUND HEAD SCREW
2405 (2405-x)	1-1/4"	3.57 [90.7]	3.50 [88.9]	2.54 [64.5]	4.01 [101.9]	#12-24 X 1-1/4" ROUND HEAD SCREW	#10-24 X 1/2" ROUND HEAD SCREW
2406 (2406-x)	1-1/2"	4.50 [114.3]	3.78 [96]	3.00 [76.2]	5.09 [129.3]	#12-24 X 1-1/4" ROUND HEAD SCREW	#10-24 X 1/2" ROUND HEAD SCREW
2408 (2408-x)	2"	5.87 [149.1]	4.95 [125.7]	3.50 [88.9]	6.61 [167.9]	#12-24 X 1-1/4" ROUND HEAD SCREW	#10-24 X 1/2" ROUND HEAD SCREW
2410 (2410-x)	2-1/2"	6.95 [176.5]	5.54 [140.7]	4.45 [113]	9.27 [235.5]	#5/16 -18 X 2" ROUND HEAD SCREW	#5/16 -18 X 3/4" ROUND HEAD SCREW
2412	3"	7.24 [183.9]	7.33 [186.2]	4.91 [124.7]	10.96 [278.4]	#5/16 -18 X 2" ROUND HEAD SCREW	#5/16 -18 X 3/4" ROUND HEAD SCREW
2414	3-1/2"	8.66 [219.9]	7.89 [200.4]	5.90 [149.9]	12.77 [324.4]	#5/16 -18 X 2" ROUND HEAD SCREW	#5/16 -18 X 3/4" ROUND HEAD SCREW
2416	4"	8.66 [219.9]	7.89 [200.4]	6.41 [162.9]	12.77 [324.4]	#5/16 -18 X 2" ROUND HEAD SCREW	#5/16 -18 X 3/4" ROUND HEAD SCREW

INSULATORS WITH MAX. WIRE DIAMETERS

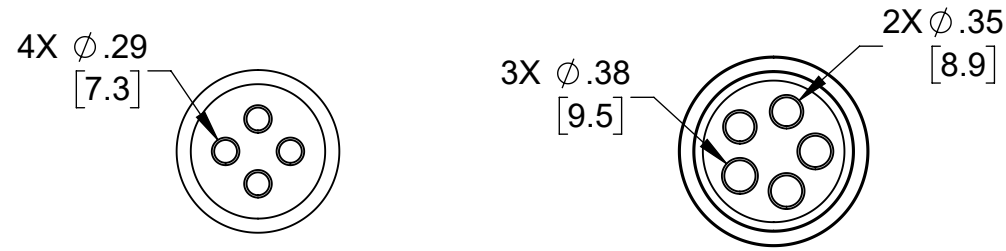

CAT. # 2402

CAT. # 2403

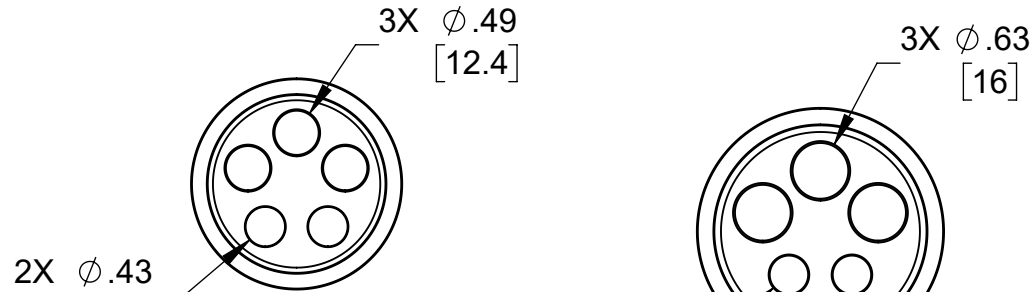

CAT. # 2404

CAT. # 2405

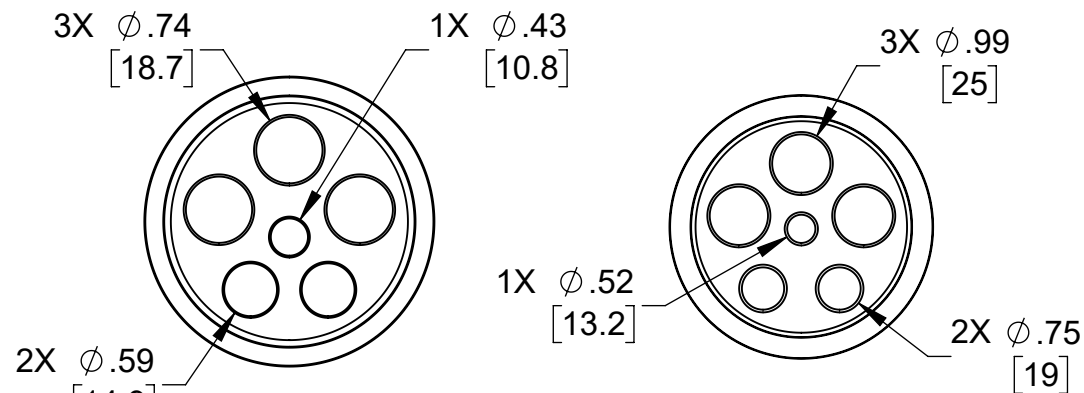

CAT. # 2406

CAT. # 2408
SCALE 1 : 3

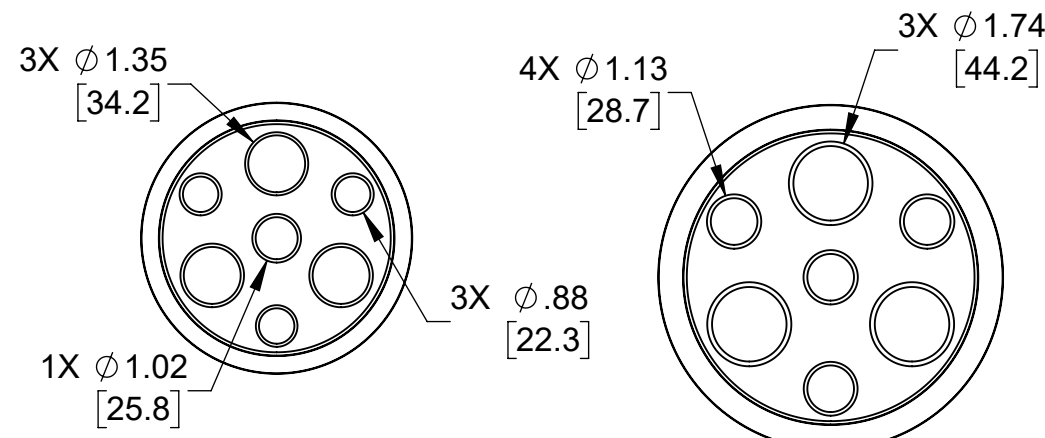

CAT. # 2410
SCALE 1 : 4

CAT. # 2412, 2414, 2416
SCALE 1 : 4

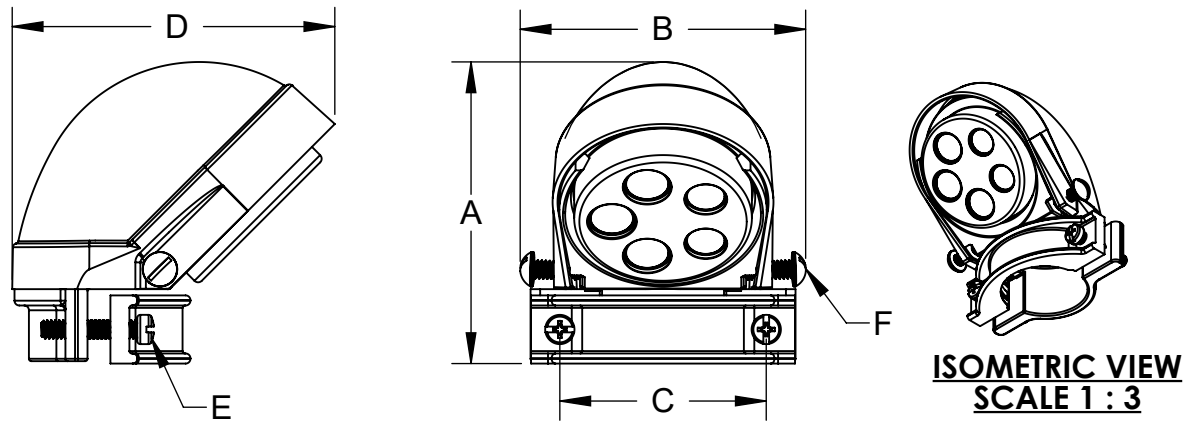

CAT. # 2402 TO 2408

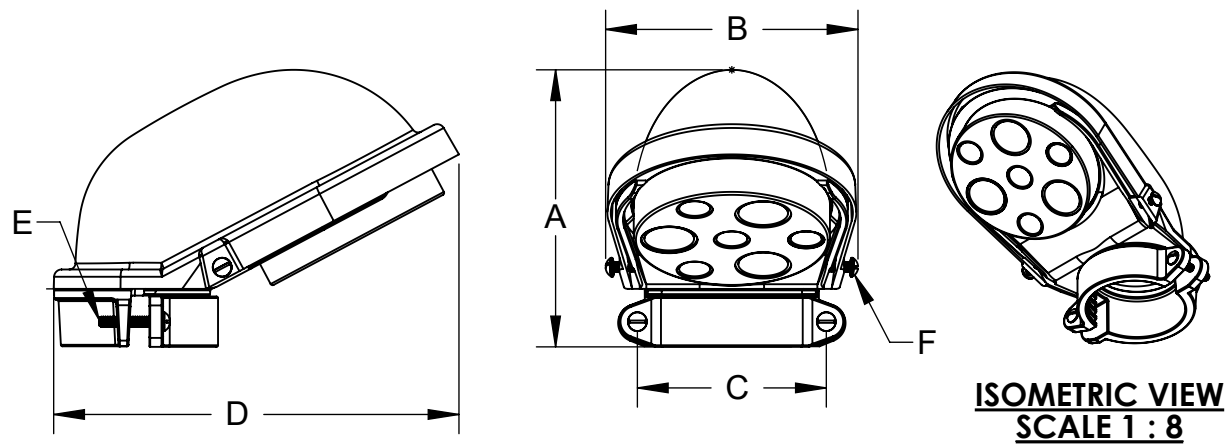

CAT. # 2410 TO 2416
SCALE 1 : 6

- NOTES:**
- ALL DIMENSIONS ARE IN INCHES AND [MILLIMETERS]
 - CSA & UL LISTED.

LIST OF PARTS		
DESCRIPTION	MATERIAL	FINISH
BODY	ALUMINUM	--
COVER	ALUMINUM	--
CLAMP	ALUMINUM	--
INSULATOR	BAKELITE	BLACK
PAN HEAD SLOTTED SCREW	STEEL	ZINC PLATED
ROUND HEAD SLOTTED SCREW	STEEL	ZINC PLATED

INITIAL RELEASE	S.J	
SYM.	REVISION DESCRIPTION	APP DATE

THE DESIGN AND DIMENSIONS OF THE PRODUCT SHOWN ON THIS DRAWING ARE SUBJECT TO CHANGE WITHOUT NOTICE

TITLE: **SERVICE ENTRANCE CAP CUS**

TOLERANCE UNLESS OTHERWISE SPECIFIED		<p>RACO South Bend, Indiana</p>	<p>SCALE: B</p>
.XX DECIMAL ±.015	DRAWN BY: F.P.		
.XXX DECIMAL ±.005	APP. BY: S.J		
ANGLE ±2°	DATE: 03-28-16		