

REVISIONS		
REV.	DATE	DESCRIPTION
-	01-05-22	INITIAL RELEASE OF DRAWING

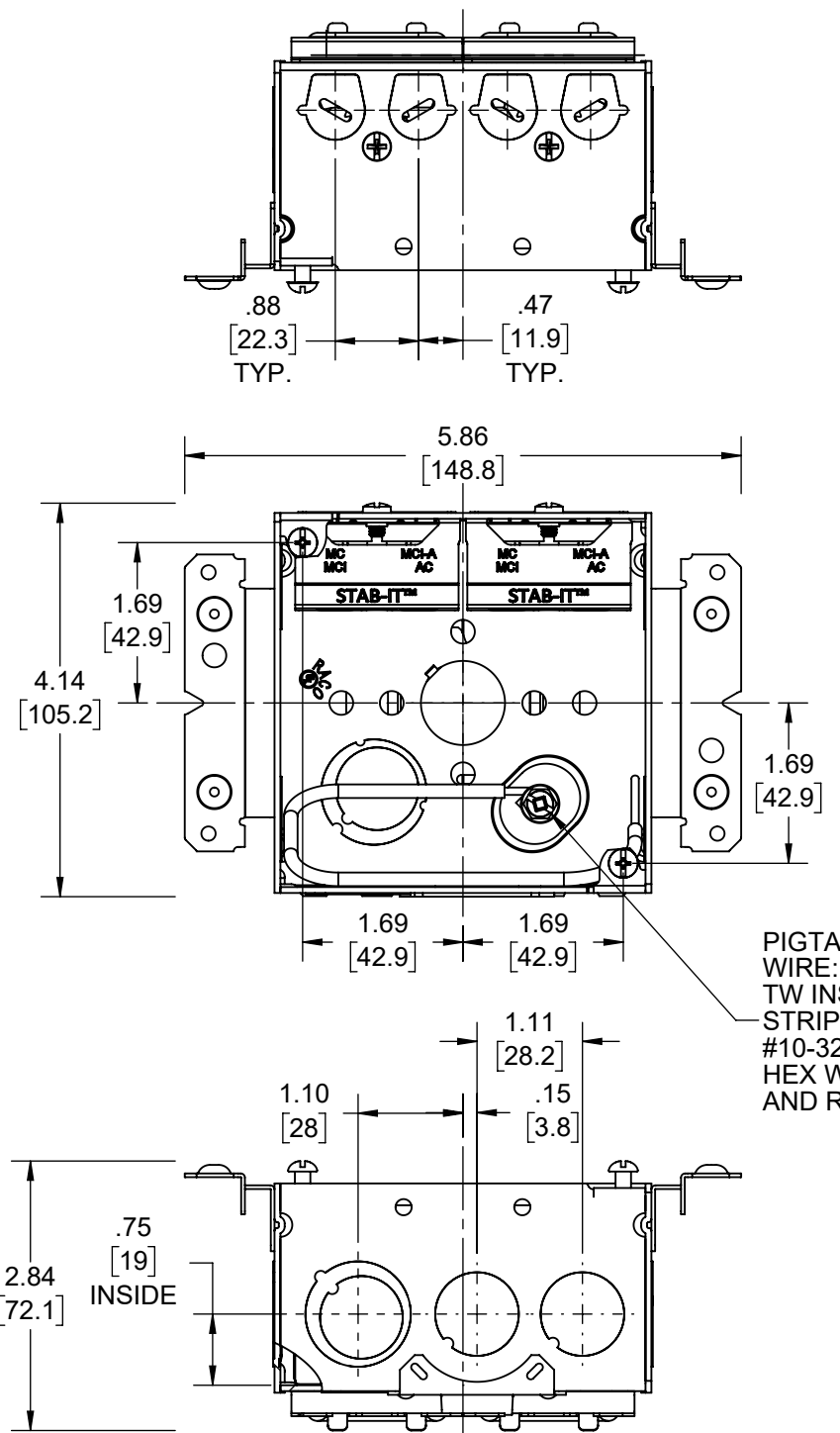

PIGTAIL:
WIRE: #12 AWG SOLID, 8-1/2" LONG, GREEN TW INSULATED, U.L. LISTED, 600 VOLT MAX, STRIPPED 1" IN FROM EACH END;
#10-32 X 3/8" GROUND SCREW W/COMBO HEX WASHER HEAD (SLOTTED, #2 PHILLIPS AND ROBERTSON)

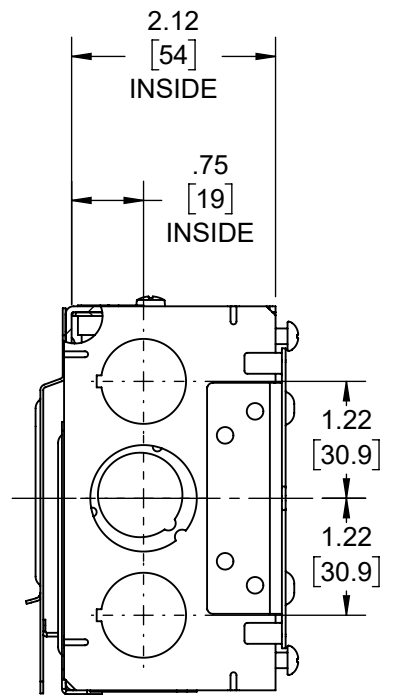
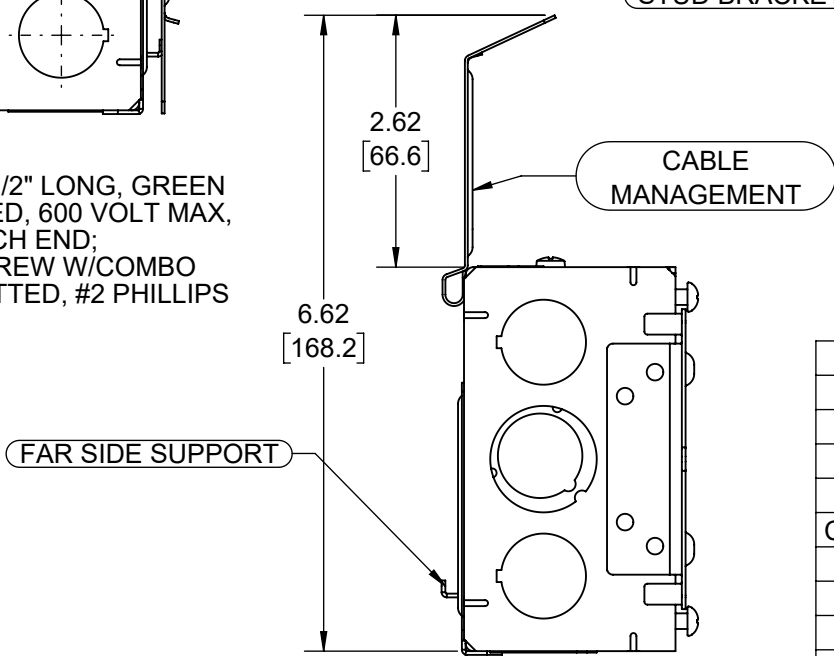
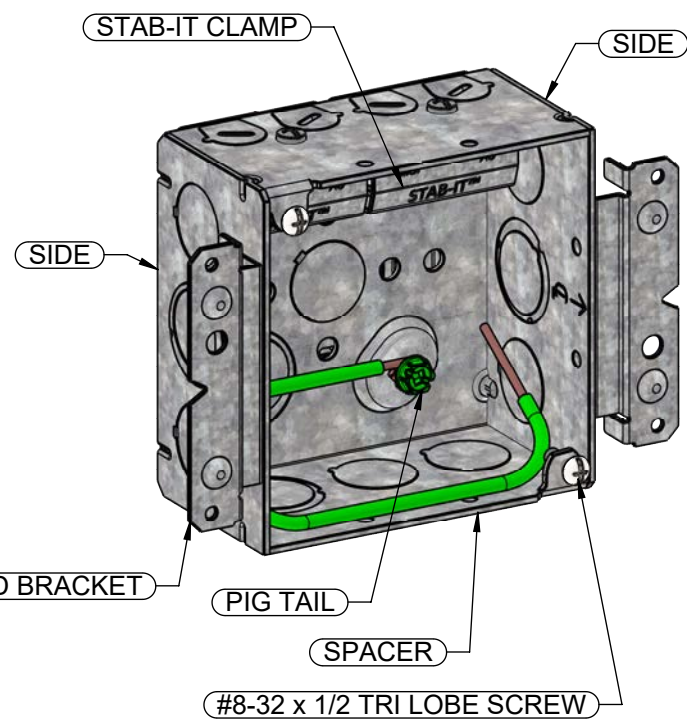
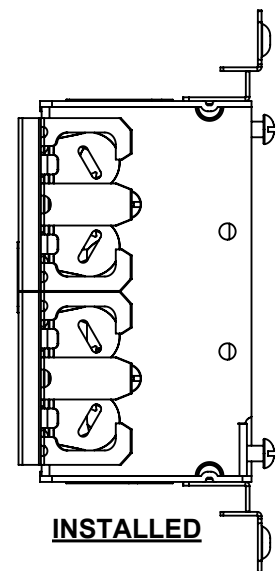

- NOTES:
1. ALL DIMENSIONS ARE IN INCHES AND [MILLIMETERS]
2. BOX VOLUME: 30.3 IN³ [496.5 CM³]
3. UL LISTED

KNOCKOUTS	
TRADE SIZE	LOCATION
1/2" KO	1- ON THE BOTTOM (ACCESSIBLE FOR 5.5" & 6" STUDS ONLY), 2-ON EACH SIDE, 2 -ON THE SIDE OF THE SPACER
1/2", 3/4" TKO®	1- ON THE BOTTOM (ACCESSIBLE FOR 5.5" & 6" STUDS ONLY), 1-ON EACH SIDE, 1-ON THE SIDE OF THE SPACER
CABLE PRIOUTS	2- ON THE SIDE OF THE SPACER

CABLE TYPES AND RANGES FOR STAB-IT CLAMP	
CABLE TYPES	CABLE RANGES
AC STEEL & ALUMINUM	14-2,14-3,14-4,12-2,12-3,12-4,10-2,10-3
HCF AC STEEL	14-2,14-3,14-4,12-2,12-3,10-2,10-3
HCF AC ALMINUM	12-2,12-3,12-4,10-2,10-3
MC STEEL & ALUMINIUM	14-2,14-3,14-4,12-2,12-3,12-4,10-2,10-3
MCI-A STEEL & ALUMINIUM	14-2,14-3,14-4,12-2,12-3,12-4,10-2,10-3
HCF MCI-A STEEL	12-2,12-3,10-2
HCF MCI-A ALUMINIUM	14-2,14-3,14-4,12-2,12-3,12-4,10-2,10-3
3/8 TRADE SIZE FLEX,REFMC CONDUIT STEEL & ALUMINUM. ANTI SHORT BUSHING REQUIRED	
CABLE RANGE .400" DIA. MIN TO .605" DIA. MAX	

DESCRIPTION	MATERIAL	FINISH
PIGTAIL	COPPER	
STAB-IT CLAMP	STEEL	GALVANIZED
FAR SIDE SUPPORT	STEEL	GALVANIZED
CABLE MANAGEMENT	STEEL	GALVANIZED
STUD BRACKET	STEEL	GALVANIZED
FASTENERS	STEEL	GALVANIZED
SIDE	STEEL	GALVANIZED
SPACER	STEEL	GALVANIZED

LIST OF PARTS
THE DESIGN AND DIMENSIONS OF THE PRODUCT SHOWN ON THIS DRAWING ARE SUBJECT TO CHANGE WITHOUT NOTICE

TITLE:
4" SQ BOX W/ FAR SIDE SUPPORT, STUD BRACKETS, 2 STAB-IT™ CLAMPS, & CABLES SUPPORT BRACKET

TOLERANCE UNLESS OTHERWISE SPECIFIED			DRAWN BY: RMV	SCALE: 1:2
.XX DECIMAL ±.015 .XXX DECIMAL ±.005 ANGLE ±2°			APP. BY: N.S.	DATE: 01-05-22

NOTE:
FOR INSTRUCTION SHEETS,
SCROLL DOWN TO SHEET 2 & 3

Instructions for using the RACO® Universal Box Stabilizer

1-1/2" Deep Boxes

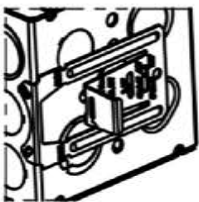

Bend center tab
as shown

For 2-1/2" deep studs

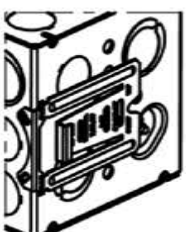

Comes preset

2-1/8" Deep Boxes

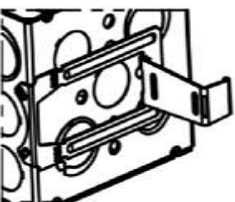

Bend center tab as
shown - 2 places

For 3-1/2" deep studs

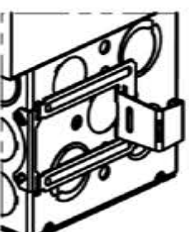

Bend center tab as
shown - 2 places

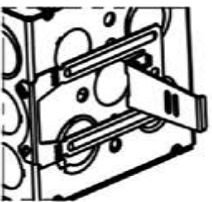

Bend center tab
as shown

For 3-5/8" deep studs

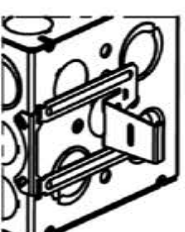

Bend center tab
as shown

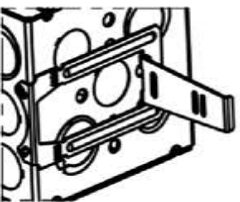

Bend center tab
as shown

For 4" deep studs

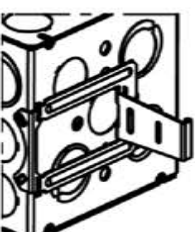

Bend center tab
as shown

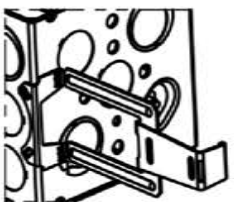

Bend both tabs
as shown

For 5-1/2" deep studs

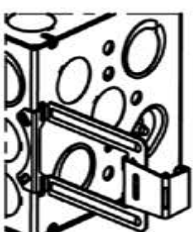

Bend both tabs
as shown

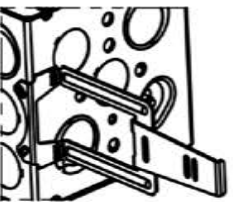

Bend both tabs
as shown

For 6" deep studs

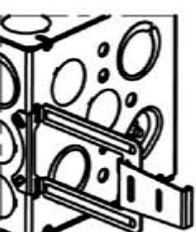

Bend both tabs
as shown

**NOTICE: Bottom knockouts are
NOT usable with the FS support.**

Instructions For Using the RACO® Cable Support Bracket with STAB-IT® Boxes

Step 1. Install box to stud.

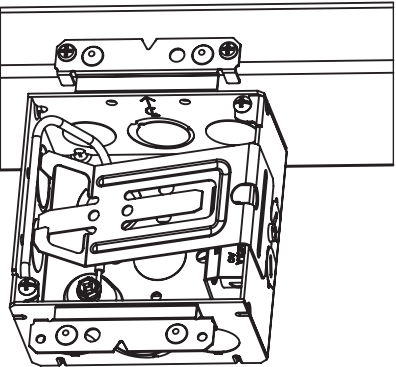

Step 2. Remove Pry-Out(s).

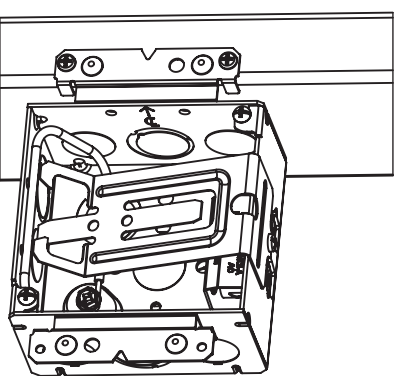

Step 3. Pre-bend Cable Support Bracket
as shown and install cables.

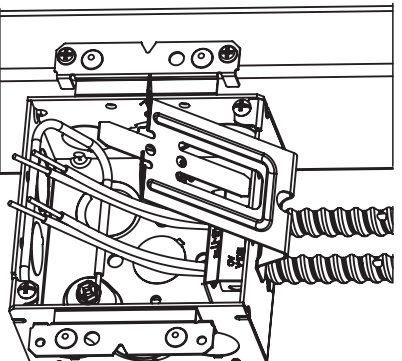

Step 4. Bend Cable Support
Bracket as shown.

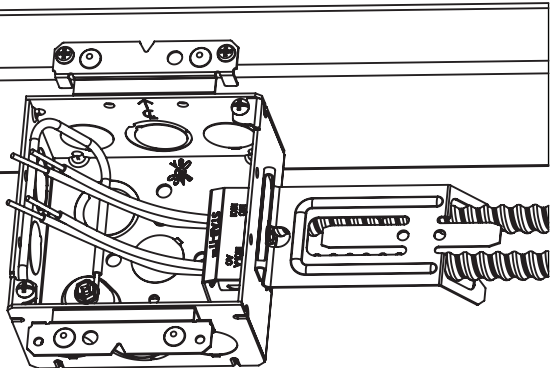

Step 5. Bend down two center tabs
to lock cables as shown.

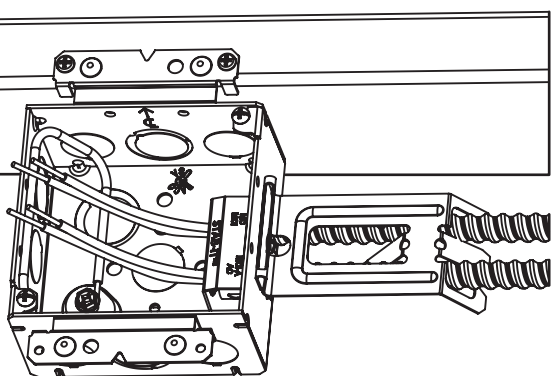

Hubbell Electrical Products
Hubbell Incorporated (Delaware)

RACO INC.

3902 W. Sample St. P.O. Box 4002 South Bend, IN 46634
Phone: (574) 234-7151 FAX (574) 283-4244

MADE IN CHINA

RA-Inst 345
119088