

U.L. LISTED 600 VOLT MAX.
 NO. 12 AWG GREEN TW INSULATED SOLID
 COPPER WIRE CUT 8-1/2" LONG IN FLAT,
 STRIPPED 1" IN FROM END.

- ADJUSTABLE
- 2-1/2" [63.5]
 - 3-1/2" [89]
 - 3-5/8" [92]
 - 4" [101.6]
 - 5.5" [140]
 - 6" [152.4]

- NOTES:
1. ALL DIMENSIONS ARE IN INCHES AND [MILLIMETERS]
 2. BOX VOLUME: 30.3 IN³ [496.5 CM³]
 3. 1 #12AWG SOLID COPPER WIRE 8" LONG PIG TAIL WITH GROUNDING SCREW INCLUDED
 4. UL LISTED
 5. FOR FAR SIDE SUPPORT BEND INSTRUCTION SEE SHEET # 2

KNOCKOUTS	
TRADE SIZE	LOCATION
1/2" KO	1- ON BACK SIDE (ACCESSIBLE FOR 5.5" & 6" STUDS ONLY), 2-ON EACH SIDE, 2 ON BOTTOM
1/2", 3/4" TKO®	1-ON EACH SIDE, 1 ON BOTTOM, 1 ON BACK

CABLE TYPES AND RANGES FOR STAB-IT CLAMP	
CABLE TYPES	CABLE RANGES
AC STEEL & ALUMINUM	14-2,14-3,14-4,12-2,12-3,12-4,10-2,10-3
HCF AC STEEL	14-2,14-3,14-4,12-2,12-3,10-2,10-3
HCF AC ALUMINUM	12-2,12-3,12-4,10-2,10-3
MC STEEL & ALUMINIUM	14-2,14-3,14-4,12-2,12-3,12-4,10-2,10-3
MCI-A STEEL & ALUMINIUM	14-2,14-3,14-4,12-2,12-3,12-4,10-2,10-3
HCF MCI-A STEEL	12-2,12-3,10-2
HCF MCI-A ALUMINIUM	14-2,14-3,14-4,12-2,12-3,12-4,10-2,10-3
3/8 TRADE SIZE FLEX,REFMC CONDUIT STEEL & ALUMINUM. ANTI SHORT BUSHING REQUIRED	
CABLE RANGE .400" DIA. MIN TO .605" DIA. MAX	

LIST OF PARTS

DESCRIPTION	MATERIAL	FINISH
SPACER	STEEL	GALVANIZED
SIDES	STEEL	GALVANIZED
STUD BRACKET	STEEL	GALVANIZED
FAR SIDE SUPPORT	STEEL	GALVANIZED
FASTENERS	STEEL	GALVANIZED
STAB-IT™ CLAMP	STEEL	GALVANIZED
PIG TAIL	COPPER	SEE NOTE

INITIAL RELEASE	N.S.	10-10-16
SYM.	REVISION DESCRIPTION	APP DATE

THE DESIGN AND DIMENSIONS OF THE PRODUCT SHOWN ON THIS DRAWING ARE SUBJECT TO CHANGE WITHOUT NOTICE

TITLE: **4" SQ. 2-1/8" DEEP WELDED BOX WITH 2 STAB-IT® CLAMPS, FAR SIDE SUPPORT, 2 "M" BRACKETS AND PIG TAIL**

TOLERANCE UNLESS OTHERWISE SPECIFIED		<p>RACO South Bend, Indiana</p>	SCALE: 1:2
.XX DECIMAL ±.015	DRAWN BY: K.K.		
.XXX DECIMAL ±.005	APP. BY: N.S.		
ANGLE ±2°	DATE: 10-10-16		

FARSIDE SUPPORT BEND INSTRUCTION

FOR 2.5" DEEP STUD
COMES PRESET

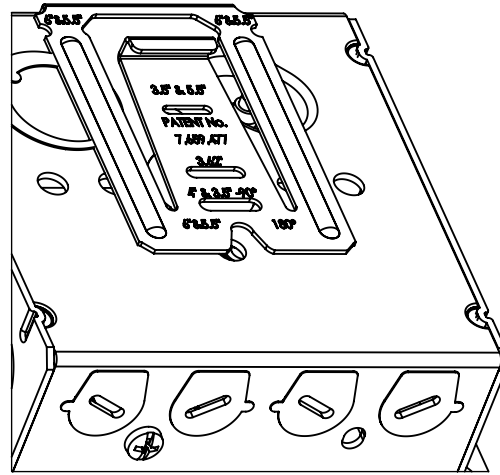

FOR 4" DEEP STUDS
BEND CENTER TAB AS
SHOWN. 1- PLACE

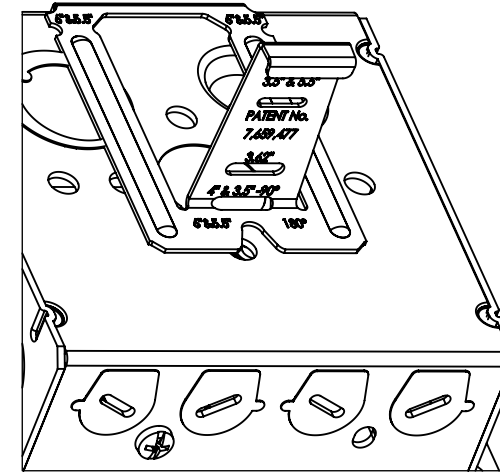

FOR 3.5" DEEP STUDS
BEND CENTER TAB AS
SHOWN. 2- PLACES

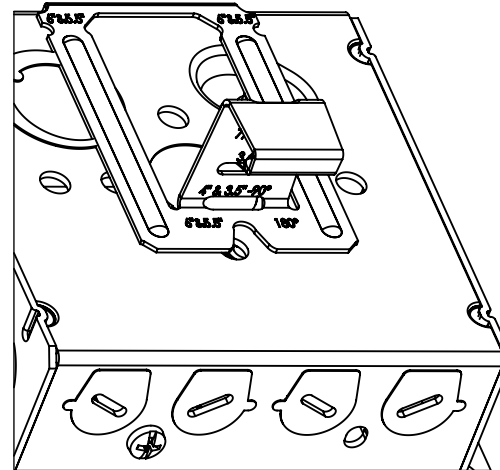

FOR 5.5" DEEP STUDS
BEND CENTER TAB AS
SHOWN. 2- PLACES

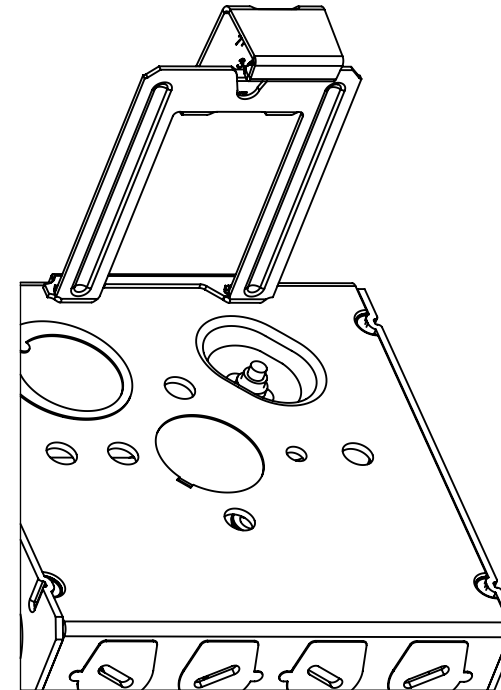

FOR 3-5/8" DEEP STUDS
BEND CENTER TAB AS
SHOWN. 1- PLACE

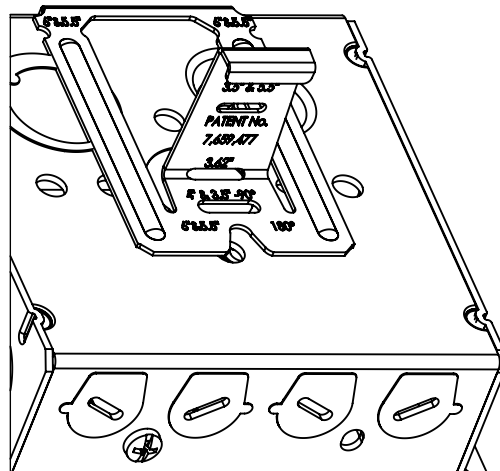

FOR 6" DEEP STUDS
BEND CENTER TAB AS
SHOWN. 2- PLACES

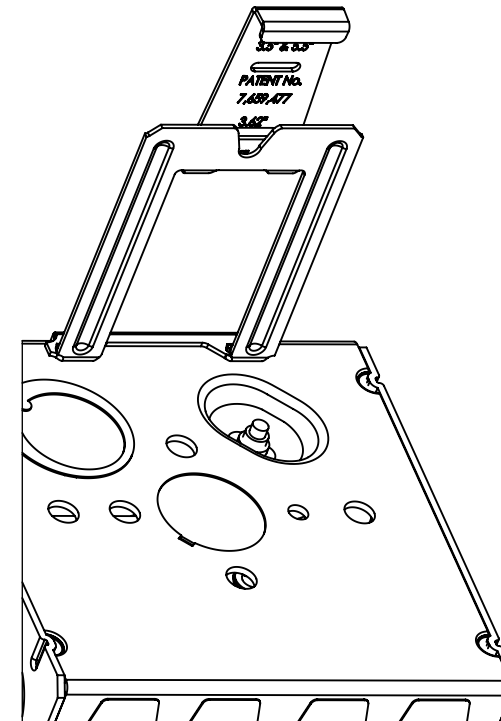

LIST OF PARTS

DESCRIPTION	MATERIAL	FINISH
SEE SHEET # 1		

SYM.	REVISION DESCRIPTION	APP	DATE
	SEE SHEET # 1		

THE DESIGN AND DIMENSIONS OF THE PRODUCT SHOWN ON THIS DRAWING ARE SUBJECT TO CHANGE WITHOUT NOTICE

TITLE: **4" SQ. 2-1/8" DEEP WELDED BOX WITH 2 STAB-IT® CLAMPS, FARSIDE SUPPORT, 2 "M" BRACKETS AND PIG**

TOLERANCE UNLESS OTHERWISE SPECIFIED		 South Bend, Indiana		
.XX DECIMAL ±.015	DRAWN BY: K.K.			SCALE: 2:3
.XXX DECIMAL ±.005	APP. BY: N.S.			
ANGLE ±2°	DATE: 4/28/2015			

FILE NAME: 244MS CUS
 DIMENSION SHEET FOR CAT. NO. 244MS
 SHEET 2 OF 2
 SIZE: B