

REVISIONS			
REV.	DATE	DESCRIPTION	BY
-	10-29-19	INITIAL RELEASE	RMV

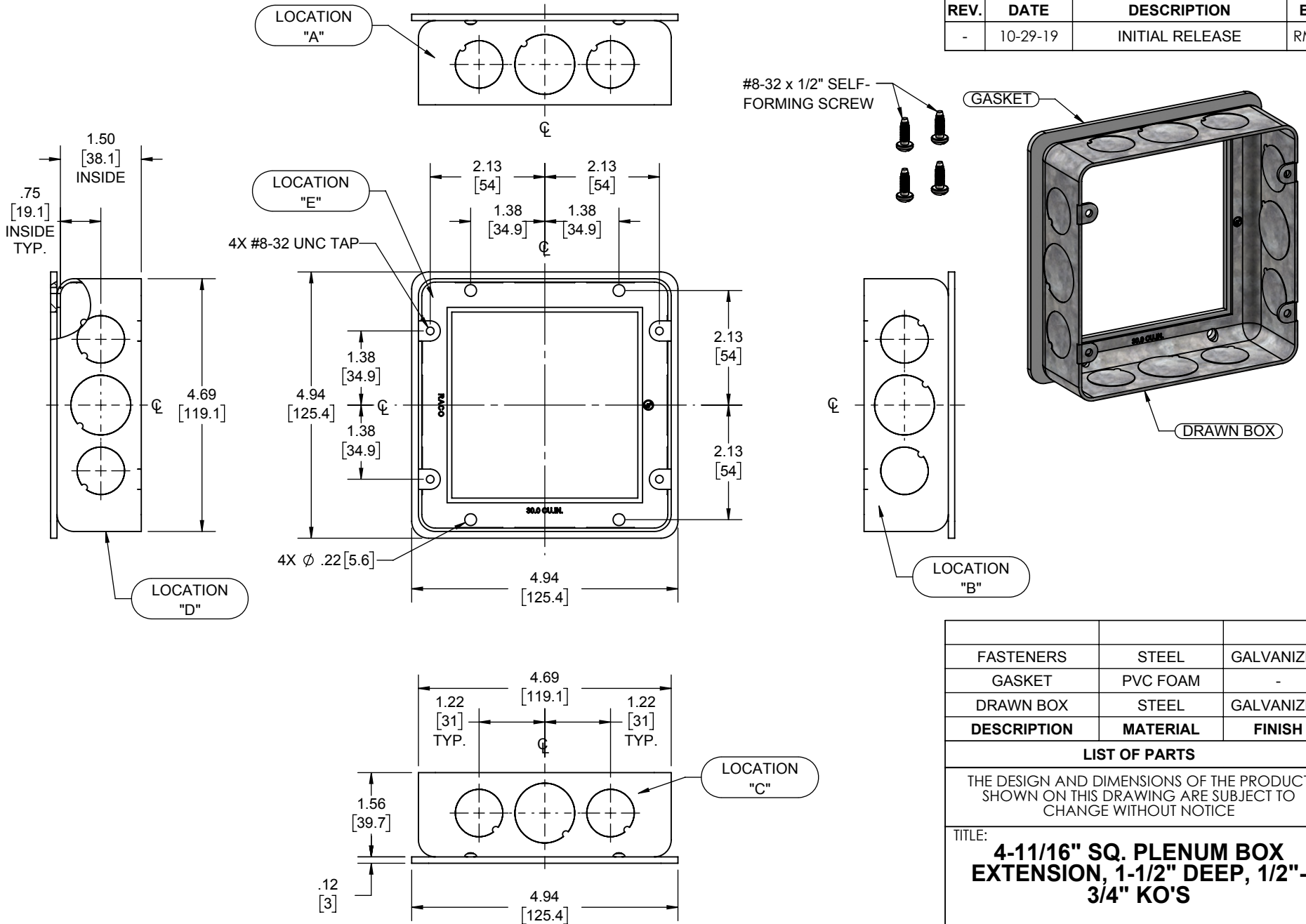

- NOTES:
1. ALL DIMENSIONS ARE IN INCHES AND [MILLIMETERS]
 2. BOX VOLUME: 30.0 IN³ [491.6 CM³]
 3. UL LISTED

KNOCKOUTS		
TRADE SIZE	LOCATION	QTY.
1/2" KO	A, B, C, D	2
3/4" KO	A, B, C, D	1

DESCRIPTION	MATERIAL	FINISH
FASTENERS	STEEL	GALVANIZED
GASKET	PVC FOAM	-
DRAWN BOX	STEEL	GALVANIZED

LIST OF PARTS

THE DESIGN AND DIMENSIONS OF THE PRODUCT SHOWN ON THIS DRAWING ARE SUBJECT TO CHANGE WITHOUT NOTICE

TITLE:
**4-11/16" SQ. PLENUM BOX
EXTENSION, 1-1/2" DEEP, 1/2"-
3/4" KO'S**

TOLERANCE UNLESS OTHERWISE SPECIFIED		RACO	
.XX DECIMAL ± .015		DRAWN BY:	RMV
.XXX DECIMAL ± .005		APP. BY:	N.S.
ANGLE ± 2°		DATE:	10-29-19
		SCALE:	1:2.5