

REVISIONS

REV.	DATE	DESCRIPTION	BY
-	05-26-22	INITIAL RELEASE	RMV

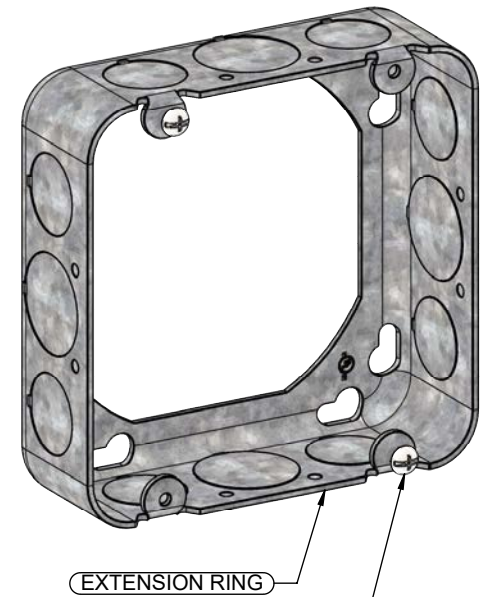
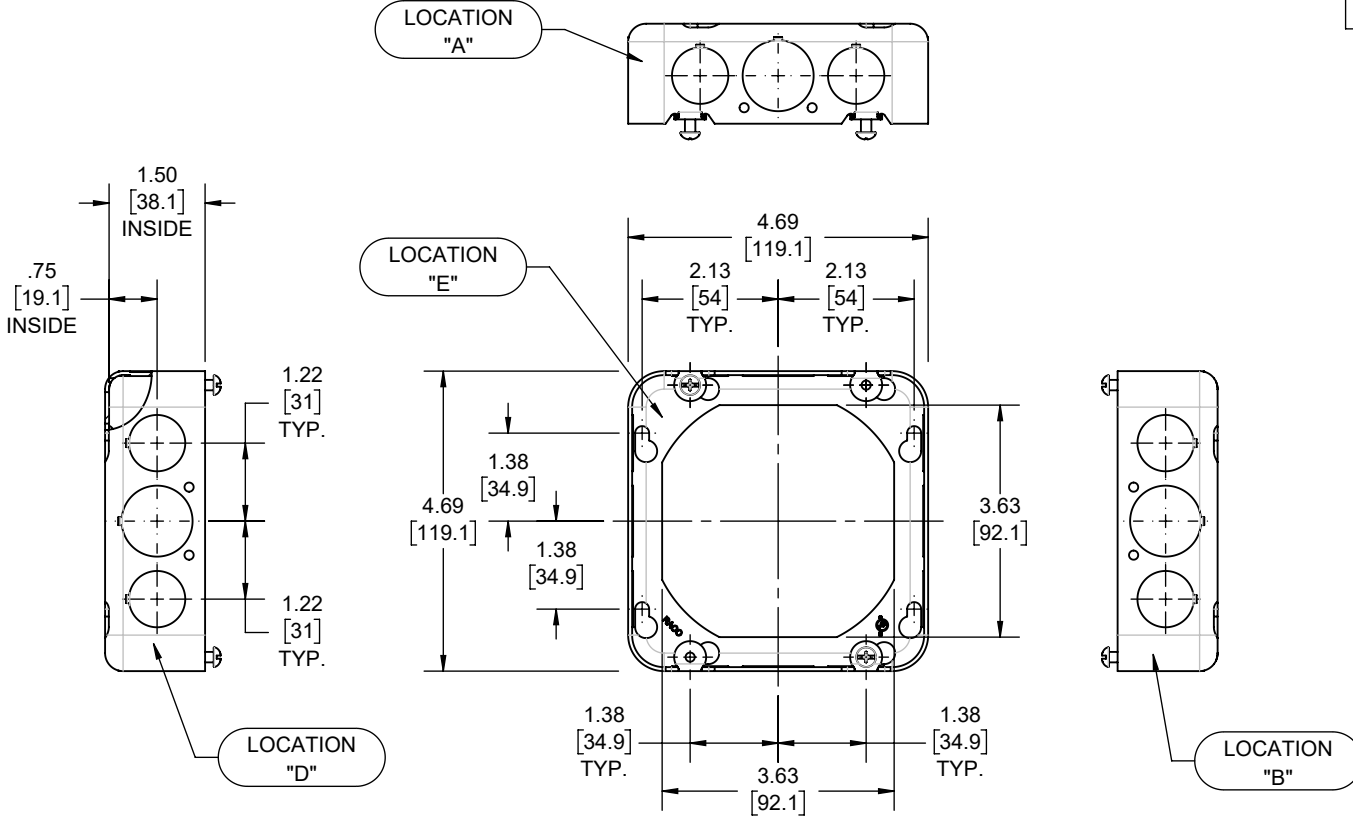

- NOTES:**
- ALL DIMENSIONS ARE IN INCHES AND [MILLIMETERS]
 - BOX VOLUME: 29.5 IN³ [483.4 CM³]
 - cULus LISTED

KNOCKOUTS		
TRADE SIZE	LOCATION	QTY.
1/2" KO	A, B, C, D	2
3/4" KO	A, B, C, D	1

DESCRIPTION	MATERIAL	FINISH
FASTENERS	STEEL	GALVANIZED
EXTENSION RING	STEEL	GALVANIZED

LIST OF PARTS

THE DESIGN AND DIMENSIONS OF THE PRODUCT SHOWN ON THIS DRAWING ARE SUBJECT TO CHANGE WITHOUT NOTICE

TITLE:
4-11/16" SQ. EXTENSION RING, 1-1/2" DP., WITH 1/2"-3/4" KO'S

TOLERANCE UNLESS OTHERWISE SPECIFIED
 .XX DECIMAL ± .015
 .XXX DECIMAL ± .005
 ANGLE ± 2°



DRAWN BY:	RMV	SCALE:	SIZE:
APP. BY:	N.S.		A
DATE:	05-26-22	1:3	