

REVISIONS			
REV.	DATE	DESCRIPTION	BY
-	06-19-15	INITIAL RELEASE OF DRAWING	JR

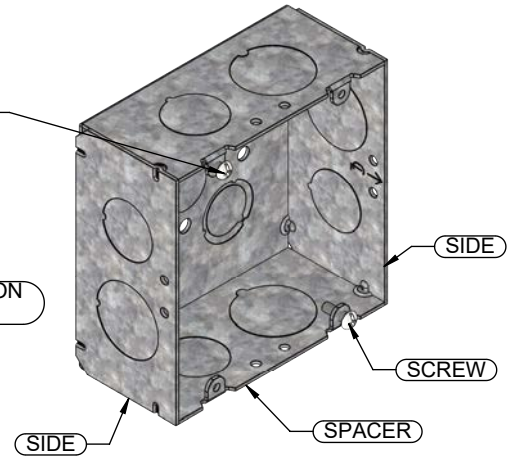
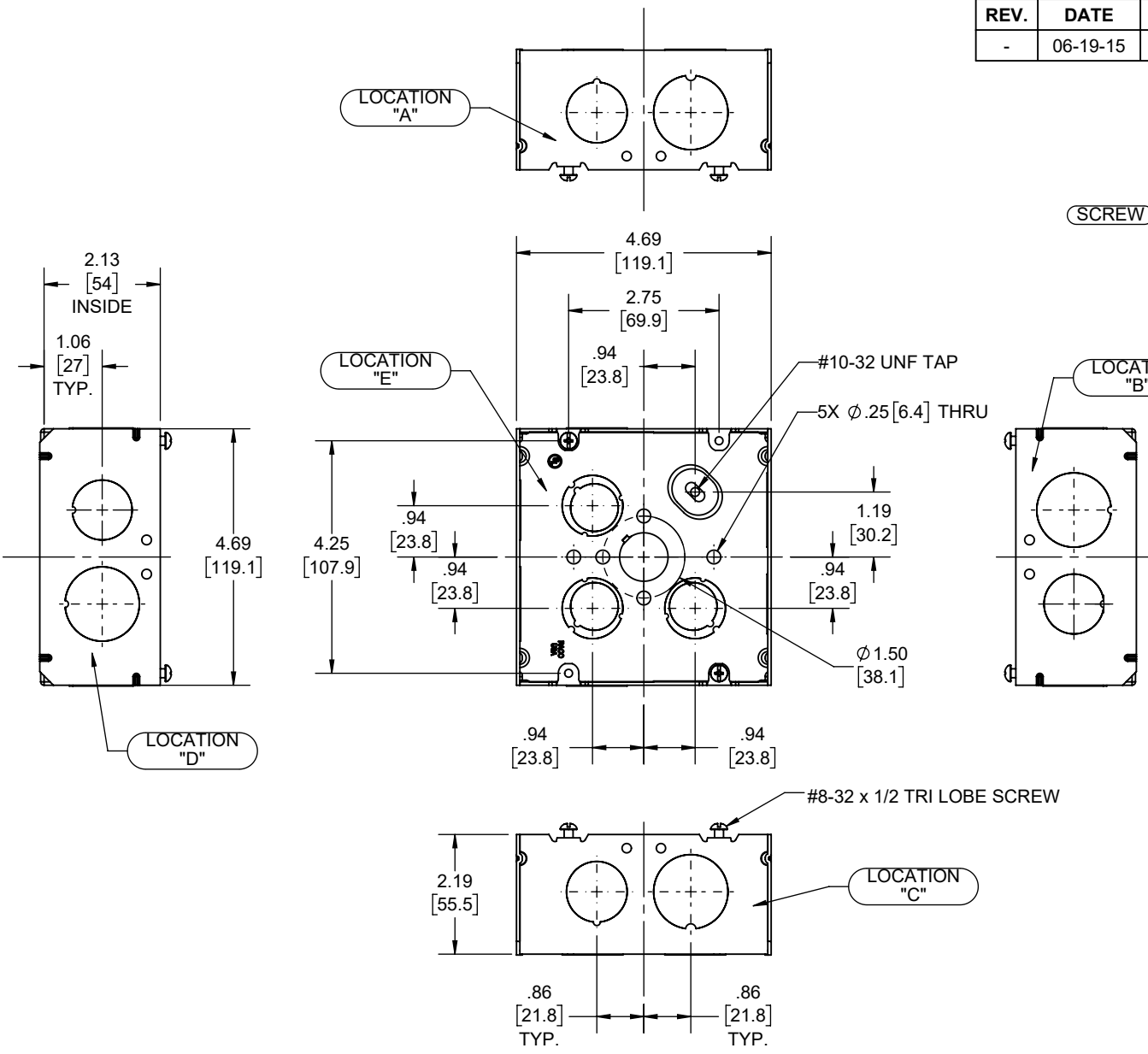

DESCRIPTION	MATERIAL	FINISH
FASTENERS	STEEL	GALVANIZED
SIDE	STEEL	GALVANIZED
SPACER	STEEL	GALVANIZED

THE DESIGN AND DIMENSIONS OF THE PRODUCT SHOWN ON THIS DRAWING ARE SUBJECT TO CHANGE WITHOUT NOTICE

TITLE:
4-11/16" SQ X 2-1/8" DP WELDED BOX W/ 3/4" & 1" KO'S

KNOCKOUTS		
TRADE SIZE	LOCATION	QTY.
1/2"	E	1
(1/2"-3/4") TKO*	E	3
3/4"	A, B, C, D	1
1"	A, B, C, D	1

TOLERANCE UNLESS OTHERWISE SPECIFIED			SCALE: 1:3
.XX DECIMAL ± .015	.XXX DECIMAL ± .005		
DATE: 06-19-15	APP. BY: N.S.	DRAWN BY: JR	SIZE: A

- NOTES:
1. ALL DIMENSIONS ARE IN INCHES AND [MILLIMETERS]
 2. BOX VOLUME: 42 IN³ [688.2 CM³]
 3. ACCEPTS ALL 4-11/16" COVERS, 707RAC & 709 PARTITIONS, ALL SOLD SEPARATELY
 4. UL LISTED