

CAT.	SIZE	A	B	C	D	E	F	G	H	J	K	L	TIGHTENING TORQUE			
													TRADE SIZE OF FITTING	METRIC DESIGNATOR	TIGHTENING TORQUE	
														N-m	(lbf-in)	
3401DC	3/8"	1.47 [37.3]	1.28 [32.5]	1.28 [32.5]	1.37 [34.8]	0.61 [15.5]	1.16 [29.5]	0.78 [19.8]	0.59 [15]	0.47 [11.9]	1/2" - 14 NPT	1 3/16" - 18 UNEF	1/4a	10	19.8	175
3402DC	1/2"	1.4 [35.6]	1.28 [32.5]	1.29 [32.8]	1.38 [35.1]	0.61 [15.5]	1.07 [27.2]	0.8 [20.3]	0.58 [14.7]	0.48 [12.2]	1/2" - 14 NPT	1 3/16" - 18 UNEF	3/8	12	22.6b	200
3403DC	3/4"	1.43 [36.3]	1.48 [37.6]	1.58 [40.1]	1.69 [42.9]	0.82 [20.8]	1.05 [26.7]	0.81 [20.6]	0.81 [20.6]	0.52 [13.2]	3/4" - 14 NPT	1 7/16" - 18 UNEF	1/2	16	33.9	300
3404DC	1"	1.87 [47.5]	1.75 [44.5]	1.84 [46.7]	1.94 [49.3]	1 [25.4]	1.36 [34.5]	1.09 [27.7]	0.7 [17.8]	0.65 [16.5]	1" - 11 1/2 NPT	1 11/16" - 18 UNEF	3/4	21	56.5	500
3405DC	1-1/4"	1.88 [47.8]	2.23 [56.6]	2.27 [57.7]	2.42 [61.5]	1.36 [34.5]	1.5 [38.1]	1.09 [27.7]	0.85 [21.6]	0.65 [16.5]	1 1/4" - 11 1/2 NPT	2 1/8" - 16 UNEF	1	27	79.1	700
3406DC	1-1/2"	1.97 [50]	2.48 [63]	2.48 [63]	2.64 [67.1]	1.6 [40.6]	1.45 [36.8]	1.21 [30.7]	0.85 [21.6]	0.71 [18]	1 1/2" - 11 1/2 NPT	2 3/8" - 16 UNEF	1-1/4	35	113	1000
3408DC	2"	1.95 [49.5]	2.9 [73.7]	3.01 [76.5]	3.25 [82.6]	2.07 [52.6]	1.48 [37.6]	0.13 [3.3]	0.84 [21.3]	0.64 [16.3]	2" - 11 1/2 NPT	2 1/2" - 11 1/2 UNEF	1-1/2	41	136	1200
													2	53	181	1600
													2-1/2	63	181	1600
													3	78	181	1600
													3-1/2	91	181	1600
													4	103	181	1600

TIGHTENING TORQUE			
TRADE SIZE OF FITTING	METRIC DESIGNATOR	TIGHTENING TORQUE	
		N-m	(lbf-in)
1/4a	10	19.8	175
3/8	12	22.6b	200
1/2	16	33.9	300
3/4	21	56.5	500
1	27	79.1	700
1-1/4	35	113	1000
1-1/2	41	136	1200
2	53	181	1600
2-1/2	63	181	1600
3	78	181	1600
3-1/2	91	181	1600
4	103	181	1600

a APPLIES TO FLEXIBLE CORD FITTINGS ONLY
b A 3/8 (12) TRADE-SIZE FITTING FOR USE WITH LIQUID-TIGHT FLEXIBLE METAL CONDUIT SHALL BE TIGHTENED WITH A TORQUE OF 26.5 N-M (235 LBF-IN).

LIST OF PARTS		
DESCRIPTION	MATERIAL	FINISH
BODY	ZINC ALLOY	BURNISHED
NUT	ZINC ALLOY	BURNISHED
LOCK NUT	ZINC ALLOY	BURNISHED
FERRULE	ZINC ALLOY	BURNISHED
SEALING RING	POLYETHYLENE	PURPLE
GLAND	POLYETHYLENE	PURPLE

NOTES:

1. ALL DIMENSIONS ARE IN INCHES AND [MILLIMETERS].
2. LOCKNUT SHALL BE HAND-TIGHTENED AND THEN FURTHER TIGHTENED 1/4 TURN WITH A HAMMER AND A FLAT BLADED SCREWDRIVER OR BY AN EQUIVALENT METHOD.
3. LIQUID TIGHT.
4. cULus LISTED.

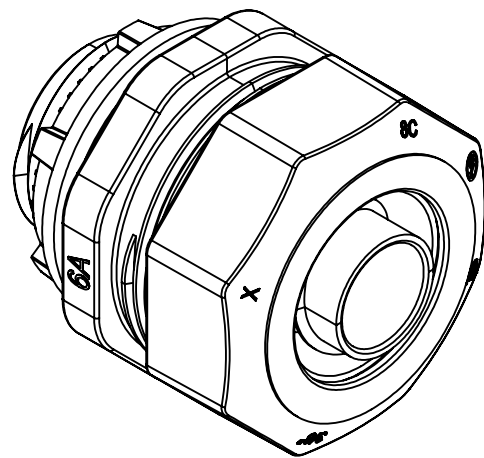

ISOMETRIC VIEW

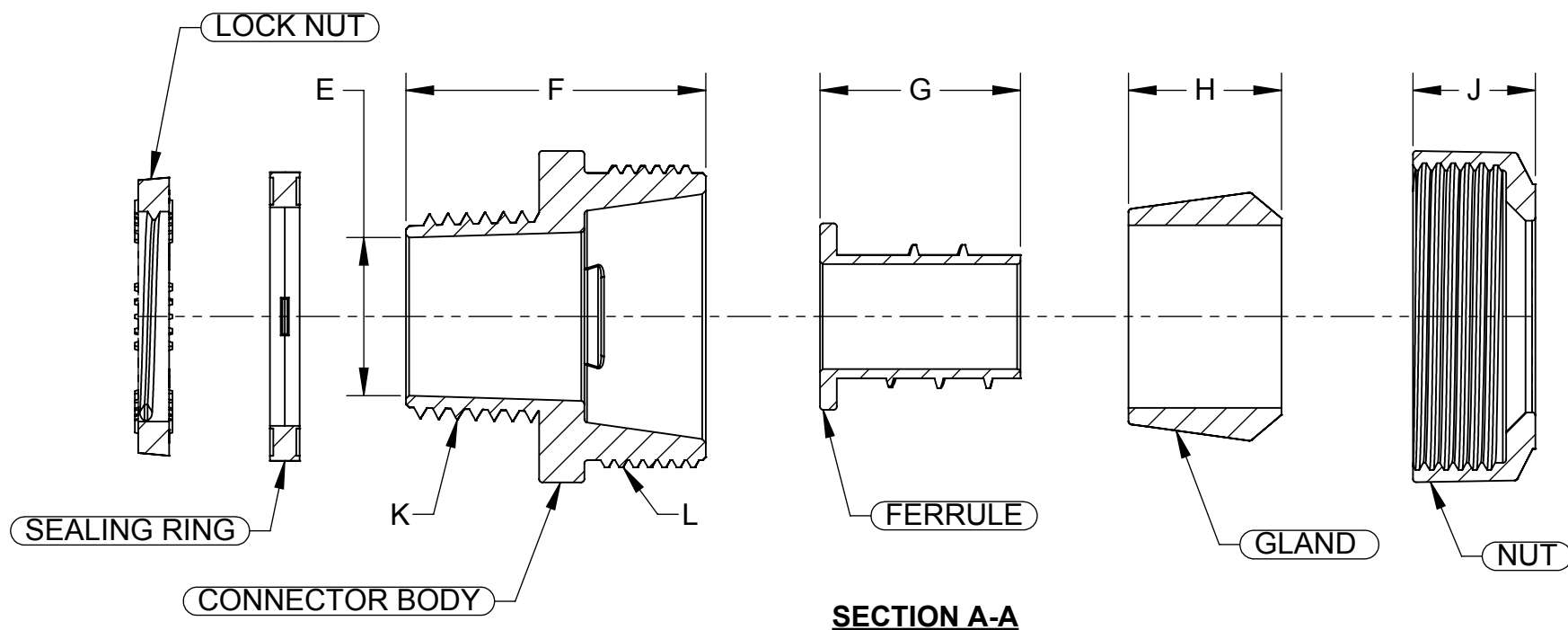
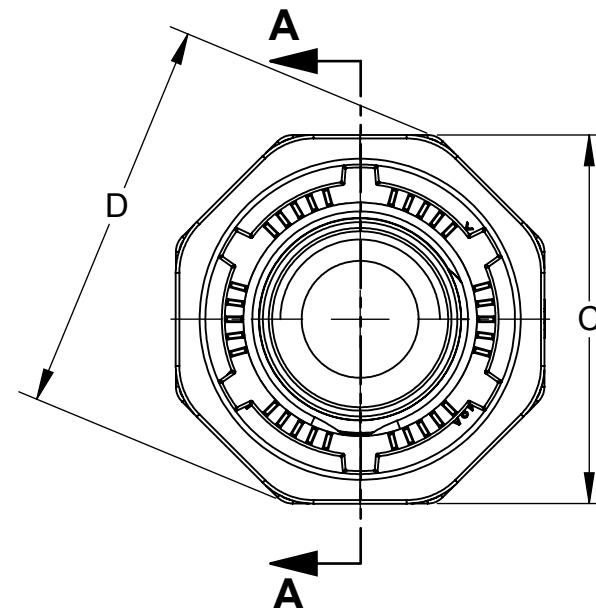
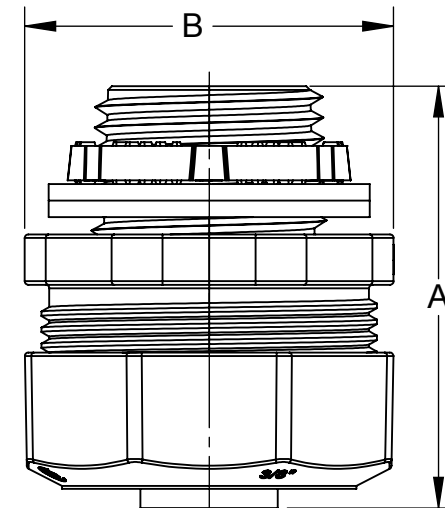

INITIAL RELEASE	S.J.	04/26/2017
REVISION DESCRIPTION	APP	DATE

THE DESIGN AND DIMENSIONS OF THE PRODUCT SHOWN ON THIS DRAWING ARE SUBJECT TO CHANGE WITHOUT NOTICE

TITLE:
ZINC DIE-CAST LIQUID TIGHT CONNECTOR-UNINSULATED CUS

TOLERANCE UNLESS OTHERWISE SPECIFIED		
.XX DECIMAL ±.015	RACO South Bend, Indiana	
.XXX DECIMAL ±.005	DRAWN BY: S.K	SCALE: 3:2
ANGLE ±2°	APP. BY: S.J.	
	DATE: 04/26/2017	