

REVISIONS			
REV.	DATE	DESCRIPTION	BY:
-	06-11-19	INITIAL RELEASE	DL

FILE NO.:  
38RAC CUS

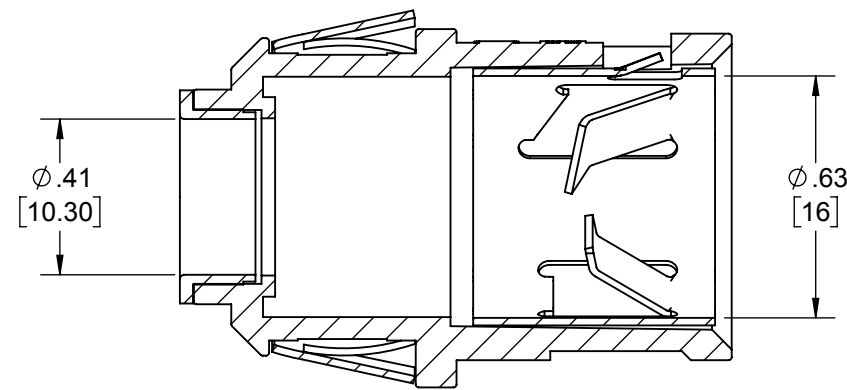
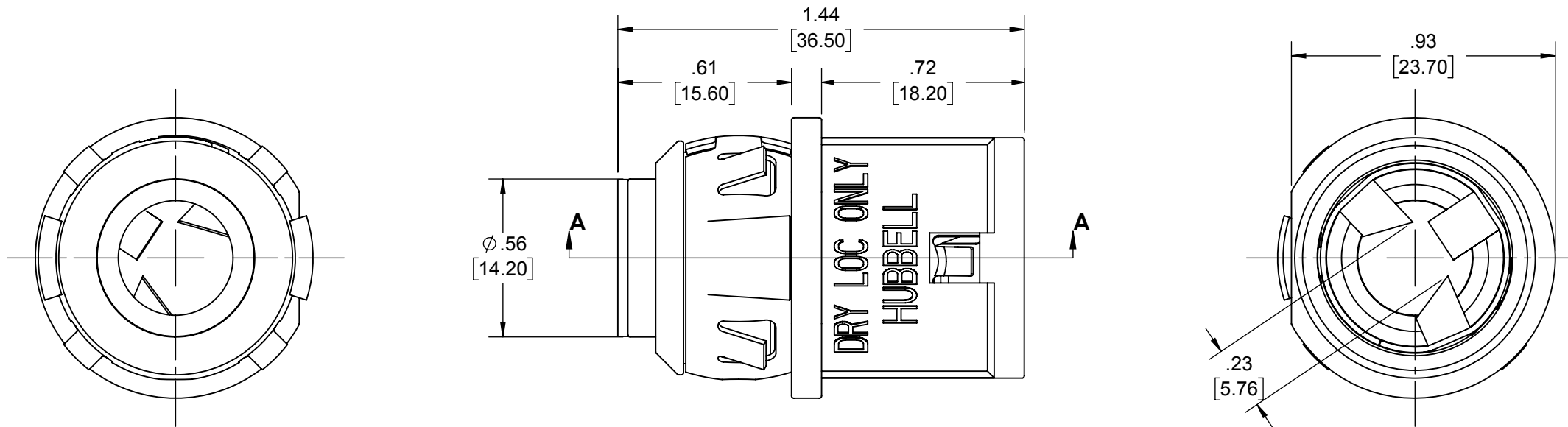
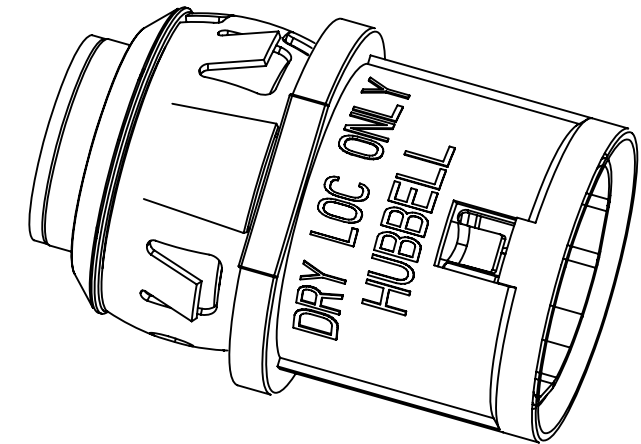

SECTION A-A  
SCALE 2 : 1

DESCRIPTION	MATERIAL	FINISH
SPRING	STEEL	GALVANIZED
3/8" CONNECTOR BODY	DIE CAST	GALVANIZED

LIST OF PARTS

THE DESIGN AND DIMENSIONS OF THE PRODUCT SHOWN ON THIS DRAWING ARE SUBJECT TO CHANGE WITHOUT NOTICE

TITLE: 3/8" CONNECTOR

CABLE DIAMETER RANGE 0.402" -0.61"	
CABLE TYPE (STEEL ALUMINUM)	CABLE RANGES
MC	14/2 - 10/3
MCI-A	14/2 - 10/3
AC/HCF	14/2 - 10/3
MCI-A-HCF	12/2 - 10/3
MC-PCS (SOLID)	12/2 - 12/3
RWFMC CONDUIT	3/8" TRADE SIZE FLEX ANTI SHORT BUSHING REQUIRED

TOLERANCE UNLESS OTHERWISE SPECIFIED  
.XX DECIMAL ±.015  
.XXX DECIMAL ±.005  
ANGLE ±2°



DRAWN BY: DL  
APP. BY: N.S.  
DATE: 06-11-19

SCALE: 1:1  
SIZE: B

- NOTES:  
1. ALL DIMENSIONS ARE IN INCHES AND [MILLIMETERS]  
2. cULus LISTED

38RAC DIMENSION SHEET FOR CAT. NO.

8.1111\*in5.8

### 38RAC/40RAC CONNECTOR REMOVAL INSTRUCTIONS

**1**

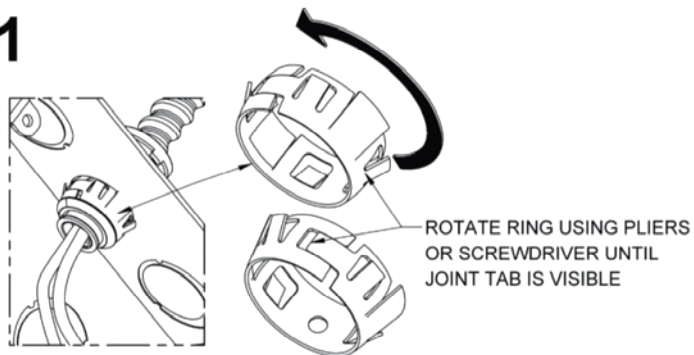

**2**

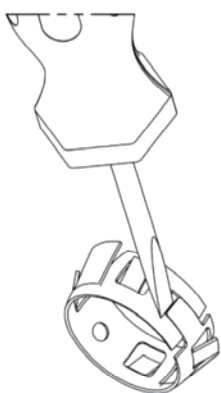

USING A SCREWDRIVER PULL  
JOINT TAB UP TO REMOVE RING



**Hubbell Commercial Construction**  
Hubbell Incorporated (Delaware)

**3**

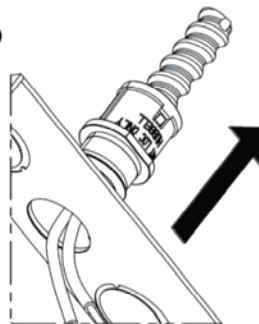

AFTER RING IS REMOVED  
SLIDE CONNECTOR OUT

**\*\*CONNECTOR CAN BE REUSED BY  
SLIDING THE RING BACK IN PLACE\*\***

RACO INC.  
3902 W. Sample St.  
P.O. Box 4002 South Bend, IN 46634  
Phone: 574-234-7151  
FAX: 574-283-4244

RA-351 Instr\_119100 rev1