

LIST OF PARTS

DESCRIPTION	MATERIAL	FINISH
SPACER	STEEL	GALVANIZED
SIDES	STEEL	GALVANIZED
PLASTER EARS	STEEL	GALVANIZED
FASTENERS	STEEL	GALVANIZED
"BN" CLAMPS	STEEL	GALVANIZED

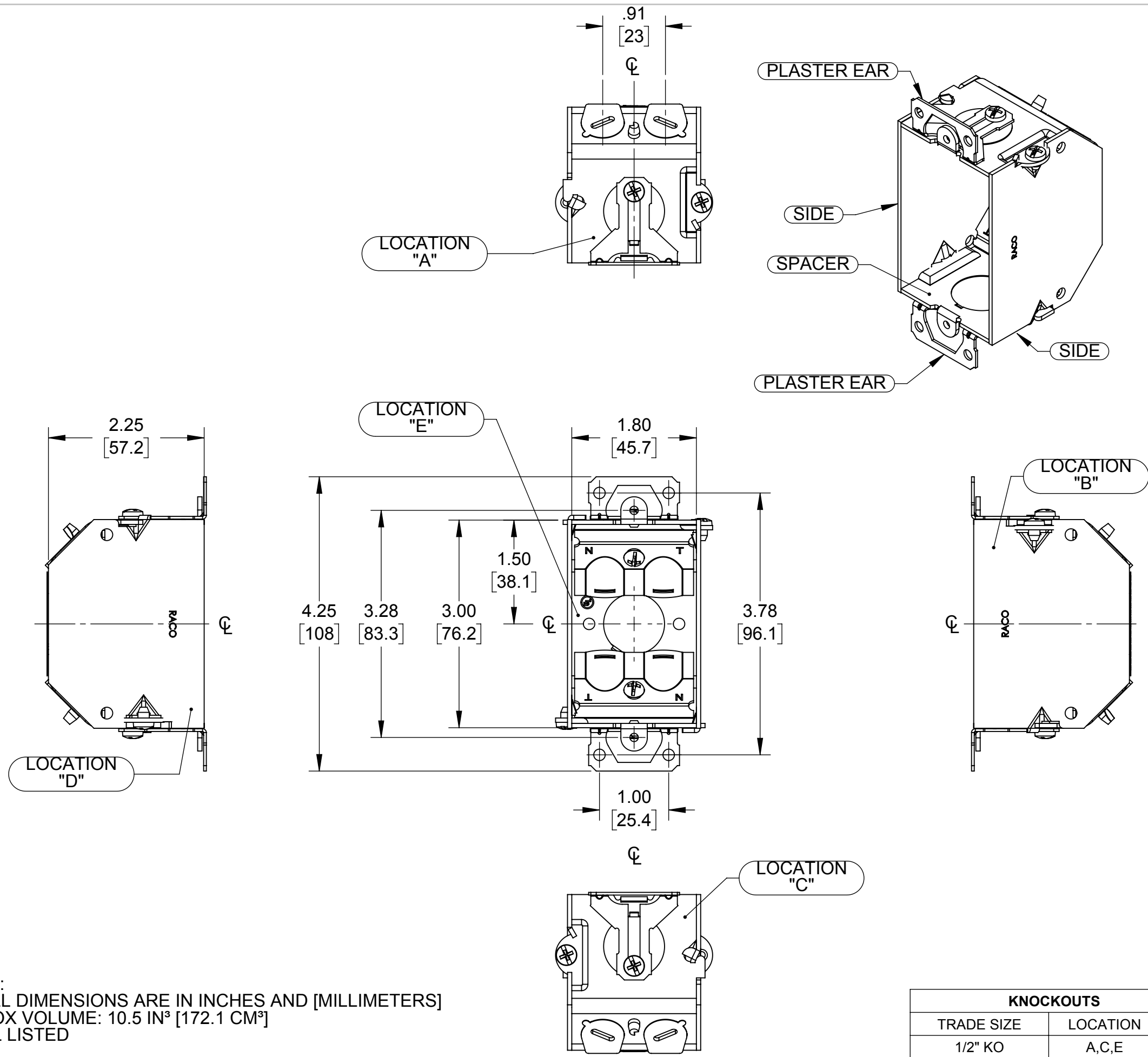

- NOTES:
1. ALL DIMENSIONS ARE IN INCHES AND [MILLIMETERS]
 2. BOX VOLUME: 10.5 IN³ [172.1 CM³]
 3. UL LISTED

KNOCKOUTS		
TRADE SIZE	LOCATION	QTY.
1/2" KO	A,C,E	1
CABLE PRIOUTS	A,C	2

TOLERANCE UNLESS OTHERWISE SPECIFIED
.XX DECIMAL ±.015
.XXX DECIMAL ±.005
ANGLE ±2°

RACO
South Bend, Indiana

DRAWN BY:	RMV	SCALE:	1:1.5
APP. BY:	N.S.		
DATE:	08-01-18		

SYMBOL	REVISION DESCRIPTION	APP	DATE
	INITIAL RELEASE	RMV	08-01-18

THE DESIGN AND DIMENSIONS OF THE PRODUCT SHOWN ON THIS DRAWING ARE SUBJECT TO CHANGE WITHOUT NOTICE

TITLE:
SWITCH BOX, 2-1/4"DP, WITH EARS, "BN" CLAMPS, AND 1/2" KO'S