

REVISIONS			
REV.	DATE	DESCRIPTION	BY
-	01-06-21	INITIAL RELEASE	RMV

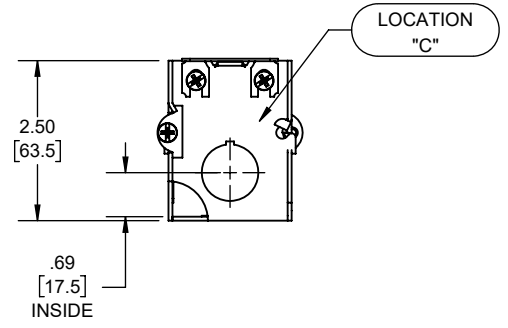
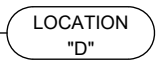
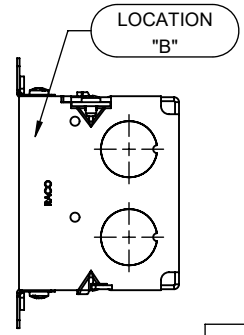
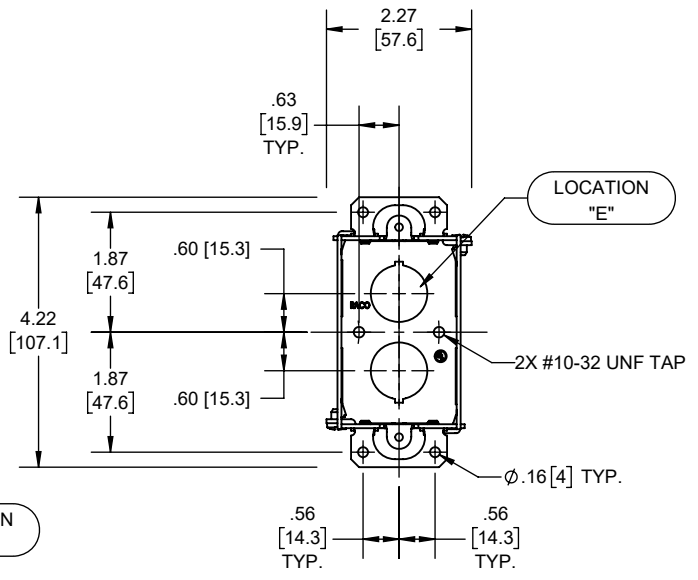
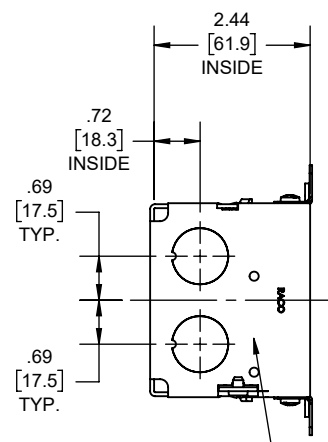
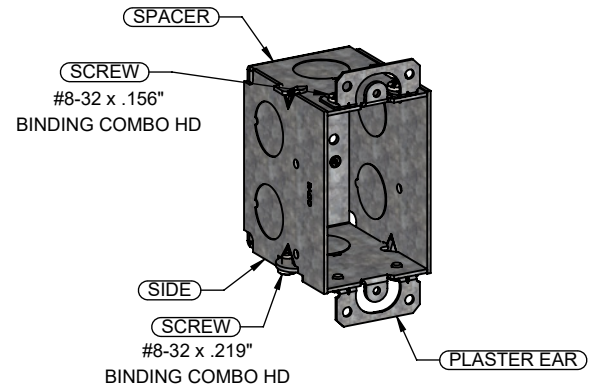
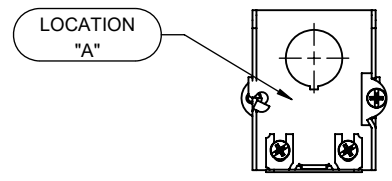

DESCRIPTION	MATERIAL	FINISH
PLASTER EAR	STEEL	GALVANIZED
FASTENERS	STEEL	GALVANIZED
SIDE	STEEL	GALVANIZED
SPACER	STEEL	GALVANIZED

LIST OF PARTS

THE DESIGN AND DIMENSIONS OF THE PRODUCT SHOWN ON THIS DRAWING ARE SUBJECT TO CHANGE WITHOUT NOTICE

TITLE:
2-1/2 IN DEEP SW BOX PLASTER EARS 1/2 KO

- NOTES:
- ALL DIMENSIONS ARE IN INCHES AND [MILLIMETERS]
 - BOX VOLUME: 12.5 IN³ [204.8 CM³]
 - UL LISTED

KNOCKOUTS		
TRADE SIZE	LOCATION	QTY.
1/2" KO	A, C	1
1/2" KO	B, D, E	2

TOLERANCE UNLESS OTHERWISE SPECIFIED
 .XX DECIMAL ± .015
 .XXX DECIMAL ± .005
 ANGLE ± 2°



DRAWN BY: RMV
 APP. BY: N.S.
 DATE: 01-06-21

SCALE: 1:3