

LIST OF PARTS

DESCRIPTION	MATERIAL	FINISH
SPACER	STEEL	GALVANIZED
SIDES	STEEL	GALVANIZED
FASTENERS	STEEL	GALVANIZED

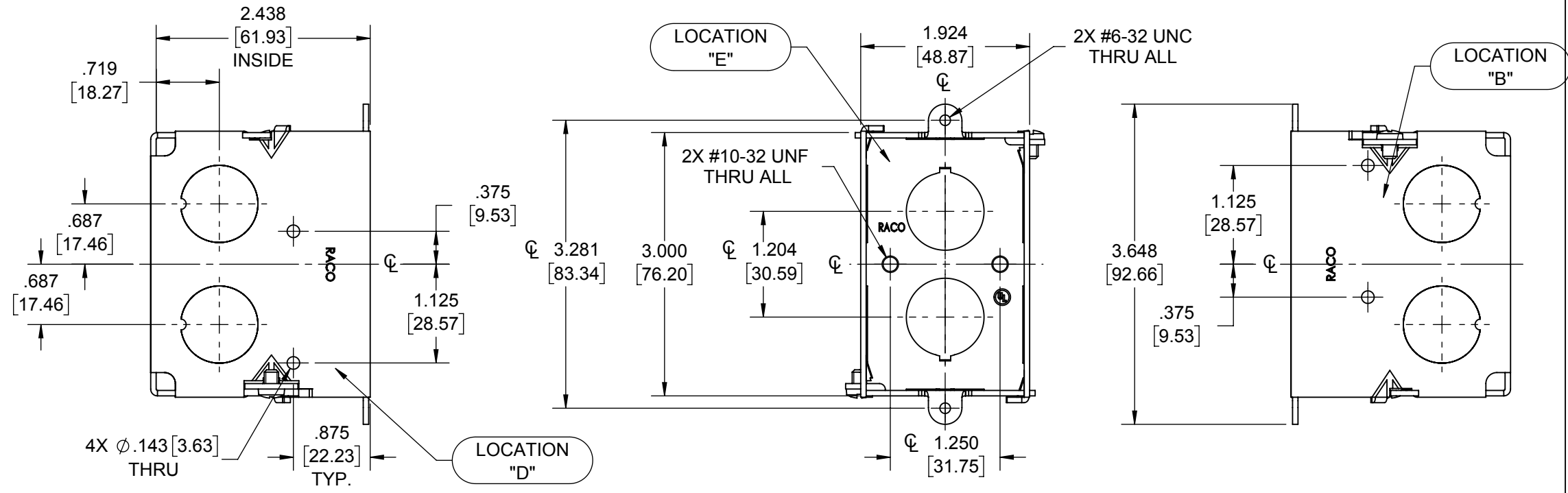
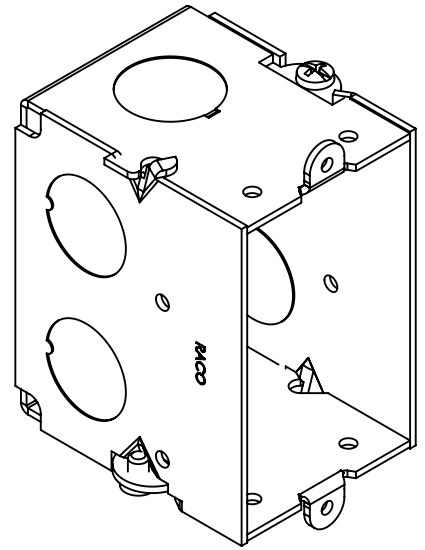

NOTES:
 1. ALL DIMENSIONS ARE IN INCHES AND [MILLIMETERS]
 2. BOX VOLUME: 12.5 IN³ [204.8 CM³]
 3. UL LISTED

KNOCKOUTS		
TRADE SIZE	LOCATION	QTY.
1/2" KO	A, C	1
1/2" KO	B, D, E	2

TOLERANCE UNLESS OTHERWISE SPECIFIED
 .XX DECIMAL ±.015
 .XXX DECIMAL ±.005
 ANGLE ±2°

RACO
 South Bend, Indiana

DRAWN BY:	RMV	SCALE:
APP. BY:	N.S.	1:1.5
DATE:	03-07-18	

INITIAL RELEASE	RMV	03-07-18
SYM.	REVISION DESCRIPTION	APP DATE
THE DESIGN AND DIMENSIONS OF THE PRODUCT SHOWN ON THIS DRAWING ARE SUBJECT TO CHANGE WITHOUT NOTICE		
TITLE: 2-1/2" DP SWITCH BOX W/ 1/2" KO'S		