

REVISIONS			
REV.	DATE	DESCRIPTION	BY
-	03-29-21	INITIAL RELEASE	VS

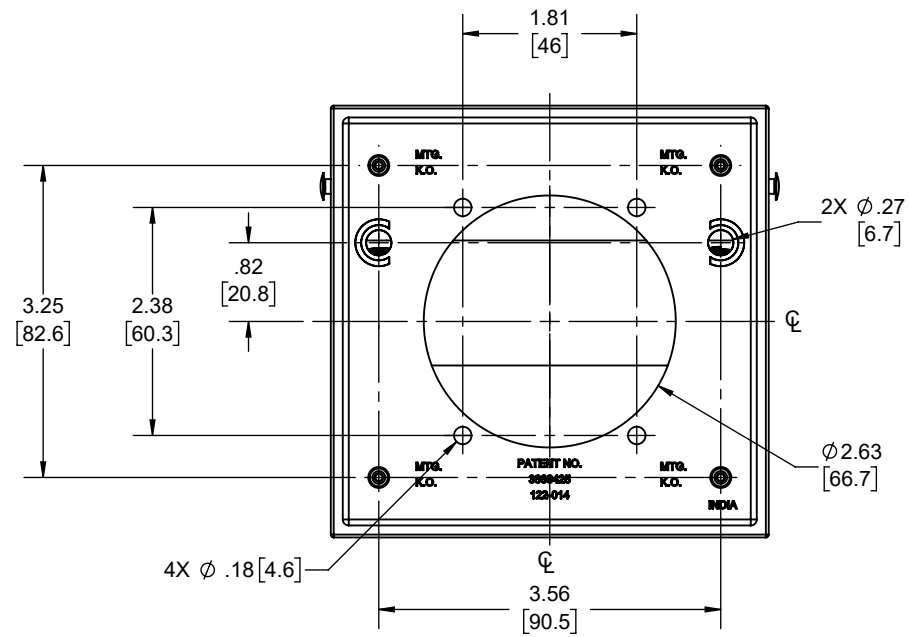

BACK VIEW

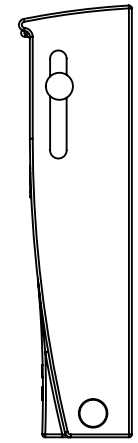
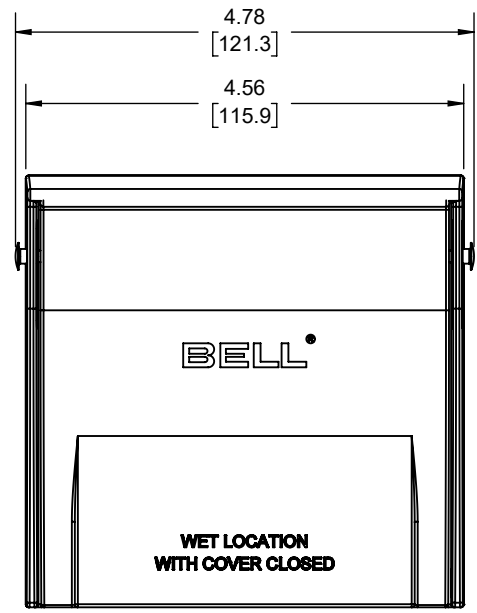
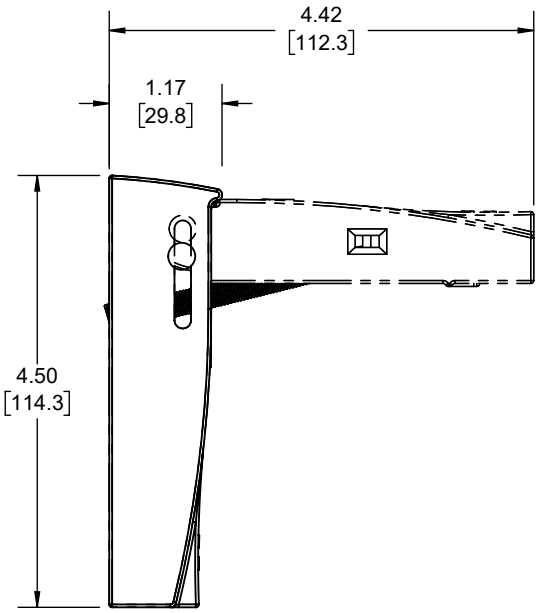
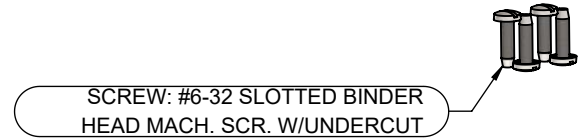
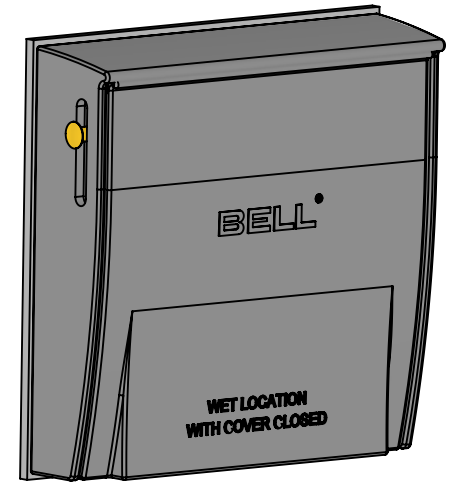

DESCRIPTION	MATERIAL	FINISH
GASKET	PF FOAM	-
FASTENERS	STEEL	GALVANIZED
COVER	DIE CAST ALUMINUM	GRAY

THE DESIGN AND DIMENSIONS OF THE PRODUCT SHOWN ON THIS DRAWING ARE SUBJECT TO CHANGE WITHOUT NOTICE

TITLE:
RAYNITE TWO GANG DEVICE COVER FOR VERTICAL ONE 2.625" DIA.

TOLERANCE UNLESS OTHERWISE SPECIFIED



.XX DECIMAL ± .015
.XXX DECIMAL ± .005
ANGLE ± 2°

DRAWN BY:	VS	SCALE:	SIZE:
APP. BY:	NS	1:2	A
DATE:	03-29-21		

- NOTES:**
1. ALL DIMENSIONS ARE IN INCHES AND [MILLIMETERS].
 2. cULus LISTED.