

REVISIONS

REV.	DATE	DESCRIPTION	BY
-	12-07-21	INITIAL RELEASE	RMV

#8-32 x 1-1/4" RND HD TYPE "T" THD CUTTING SCREW W/ COMB. PHILIPS/SLOTTED HEAD

LOCATION "A"

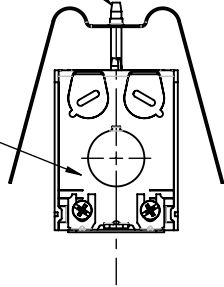

LOCATION "E"

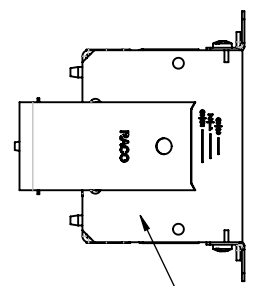

LOCATION "D"

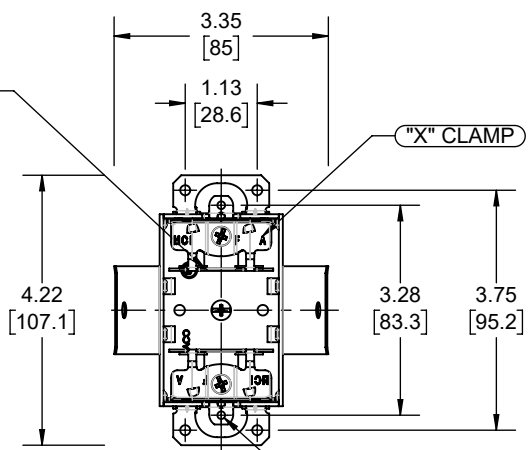

#8-32 x .156" BINDING COMBO HD

BRACKET

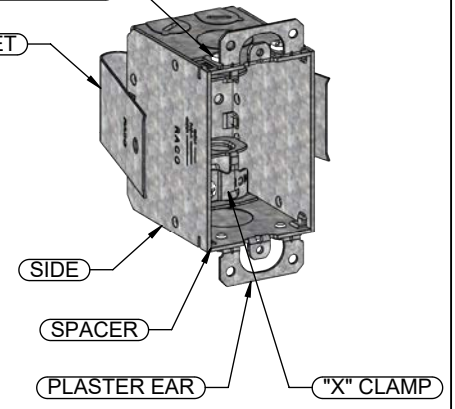

LOCATION "B"

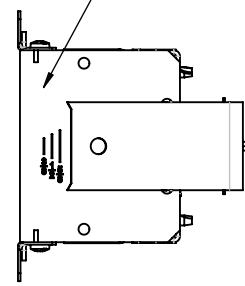

LOCATION "C"

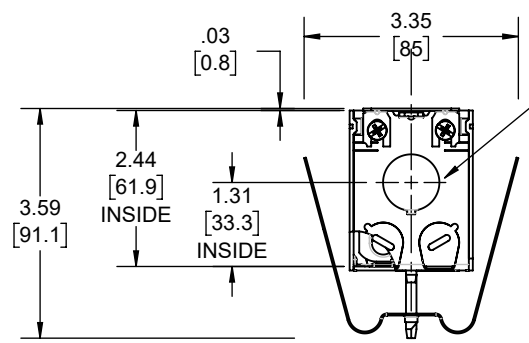

DESCRIPTION	MATERIAL	FINISH
PLASTER EAR	STEEL	GALVANIZED
"X" CLAMP	STEEL	GALVANIZED
BRACKET	STEEL	GALVANIZED
FASTENERS	STEEL	GALVANIZED
SIDE	STEEL	GALVANIZED
SPACER	STEEL	GALVANIZED

LIST OF PARTS

THE DESIGN AND DIMENSIONS OF THE PRODUCT SHOWN ON THIS DRAWING ARE SUBJECT TO CHANGE WITHOUT NOTICE

TITLE:
**SWITCH BOX, 2-1/2" DP., W/
PLASTER EARS AND "X"
CLAMPS**

TOLERANCE UNLESS OTHERWISE SPECIFIED



.XX DECIMAL ± .015
.XXX DECIMAL ± .005
ANGLE ± 2°

DRAWN BY:	RMV	SCALE:	SIZE:
APP. BY:	N.S.		
DATE:	12-07-21	1:3	A

- NOTES:
1. ALL DIMENSIONS ARE IN INCHES AND [MILLIMETERS]
 2. BOX VOLUME: 12.5 IN³ [204.8 CM³]
 3. UL LISTED

KNOCKOUTS		
TRADE SIZE	LOCATION	QTY.
1/2" KO	A, C	1