

**LIST OF PARTS**

DESCRIPTION	MATERIAL	FINISH
SPACER	STEEL	GALVANIZED
SIDES	STEEL	GALVANIZED
FASTENERS	STEEL	GALVANIZED
BRACKETS	STEEL	GALVANIZED
CLAMPS	STEEL	GALVANIZED

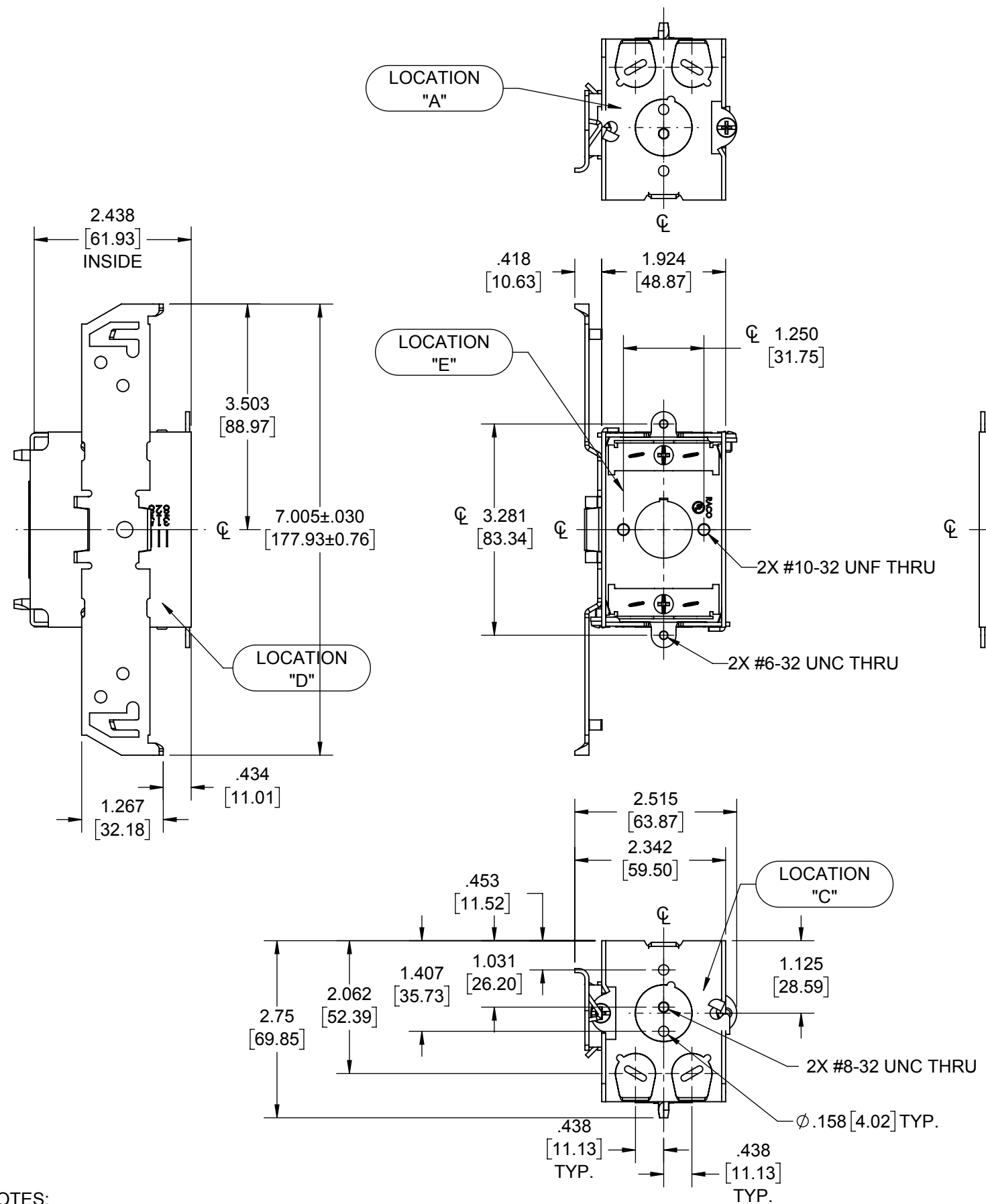
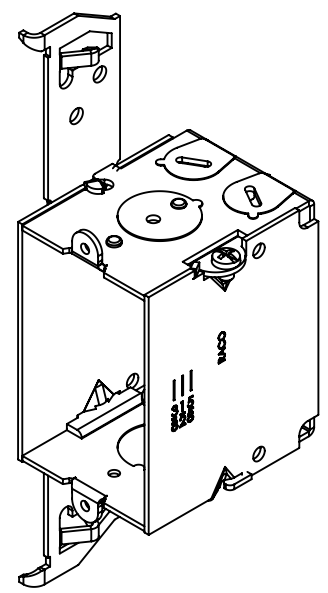

NOTES:  
 1. ALL DIMENSIONS ARE IN INCHES AND [MILLIMETERS]  
 2. BOX VOLUME: 12.5 IN<sup>3</sup> [204.8 CM<sup>3</sup>]  
 3. UL LISTED

LOCATION "B"

LOCATION "A"

LOCATION "E"

LOCATION "D"

LOCATION "C"

KNOCKOUTS		
TRADE SIZE	LOCATION	QTY.
1/2" KO	A, C, E	1

INITIAL RELEASE	RMV	03-02-18
SYM.	REVISION DESCRIPTION	APP DATE

THE DESIGN AND DIMENSIONS OF THE PRODUCT SHOWN ON THIS DRAWING ARE SUBJECT TO CHANGE WITHOUT NOTICE

TITLE: **2-1/2" DP SW BOX, TS-BRKT, NM-CLAMPS, 1/2" KO**

TOLERANCE UNLESS OTHERWISE SPECIFIED .XX DECIMAL ±.015 .XXX DECIMAL ±.005 ANGLE ±2°		<b>RACO</b> South Bend, Indiana	
		DRAWN BY: <b>RMV</b> APP. BY: <b>N.S.</b> DATE: <b>03-02-18</b>	SCALE: <b>1:2</b>